

REPAIR MANUAL



205

Publication No. 52433
2007

THOMAS

THOMAS EQUIPMENT LIABILITY WARRANTY

THE WARRANTY IS THE ONLY OBLIGATION OF THOMAS OR A THOMAS DEALER TO THE PURCHASER OR ANYONE ELSE CONCERNING A PRODUCT, ITS SERVICE, ITS USE OR PERFORMANCE OR ITS LOSS OF USE OR FAILURE TO PERFORM. NEITHER THOMAS NOR A THOMAS DEALER HAVE MADE AND NEITHER WILL MAKE ANY OTHER EXPRESSED OR IMPLIED REPRESENTATION, WARRANTY OR AGREEMENT CONCERNING A PRODUCT. NEITHER THOMAS NOR A THOMAS DEALER HAVE MADE OR WILL MAKE ANY REPRESENTATION, WARRANTY OR AGREEMENT CONCERNING A PRODUCTS MERCHANTABILITY OR OTHER QUALITY, ITS SUITABILITY FOR PURCHASER'S PURPOSE (EVEN IF A PURCHASER HAS INFORMED THOMAS OR A THOMAS DEALER OF THAT PURPOSE), ITS DURABILITY, PERFORMANCE OR OTHER CONDITION.

EVEN IF THOMAS OR A THOMAS DEALER WAS ADVISED OF THE POSSIBILITY OF SUCH LOSS, NEITHER THOMAS NOR A THOMAS DEALER WILL BE LIABLE TO PURCHASER OR ANYONE ELSE FOR ANY INDIRECT, INCIDENTAL CONSEQUENTIAL, PUNITIVE, ECONOMIC, COMMERCIAL, OR SPECIAL LOSS WHICH IS IN ANY WAY ASSOCIATED WITH A PRODUCT. THIS INCLUDES ANY LOSS OF USE OR NON-PERFORMANCE OF A PRODUCT, ANY REPLACEMENT RENTAL OR ACQUISITION COST, ANY LOSS OF REVENUE OR PROFITS, ANY FAILURE TO REALIZE EXPECTED SAVINGS, ANY INTEREST COSTS, ANY IMPAIRMENT OF OTHER GOODS, ANY INCONVENIENCE OR ANY LIABILITY OF PURCHASER TO ANY OTHER PERSON.

PURCHASER MAY NOT ATTEMPT TO ENLARGE ITS RIGHTS UNDER THE WARRANTY BY MAKING A CLAIM FOR INDEMNITY, FOR BREACH OF CONTRACT, FOR BREACH OF COLLATERAL WARRANTY, FOR A TORT (INCLUDING NEGLIGENCE, MISREPRESENTATION OR STRICT LIABILITY) OR BY CLAIMING ANY OTHER CAUSE OF ACTION.

THE WARRANTY IS A CONDITION OF SALE OF THE PRODUCT TO PURCHASER AND WILL THEREFORE APPLY EVEN IF PURCHASER ALLEGES THAT THERE IS A TOTAL FAILURE OF THE PRODUCT.

*N.B. Read and practice your **Thomas** operating and servicing instructions. Failure to do this may void your warranty.*

Publication Number 52433

TABLE OF CONTENTS

Forword

Serial Numbers	5
Safety Precautions	6 ~ 10
Service Access	11~12

Section 1

Hydraulic System

Hydraulic Circuit	1.1
Gear Pump	1.2
Control Valve	1.3
Hydraulic Cylinders	1.4
Oil Filter	1.5
Oil Cooler	1.6
Oil Reservoir	1.7
Trouble Shooting	1.8
Torque Chart	1.9
Conversion Chart	1.10

Section 2

Hydrostatic Drive System

Hydrostatic Drive Circuit & Specifications	2.1
General Information.....	2.2
Trouble Shooting	2.3
Pressure Tests.....	2.4
Flushing The Hydraulic System	2.5
Start - up Procedure	2.6
Gear Pump Replacement	2.7
Tandem Pump Replacement	2.8
Tandem Pump Parts Diagram	2.9
Drive Motor Removal & Replacement.....	2.10
Drive Motor Disassembly & Assembly.....	2.11
Torque Specifications	2.12

Section 3

Final Drive

Specifications and Maintenance	3.1
Lubrication.....	3.2
Drive Chain.....	3.3
Drive Motor Sprocket	3.4
Axle Assembly.....	3.5
Trouble Shooting	3.6

Section 4

Controls

Steering	4.1
Foot Pedals.....	4.2
Hand Controls	4.3
Throttle.....	4.4
Restraint Bar	4.5
Seat Belt	4.6
Parking Brake	4.7
Trouble Shooting	4.8

TABLE OF CONTENTS

Section 5	Electrical
Specifications	5.1
Electrical Panel	5.2
Wiring Schematics	5.3
Instrumentation	5.4
Ignition Switch	5.5
Engine Glow Plugs	5.6
Battery	5.7
Starter Circuit	5.8
Charging Circuit	5.9
Safety Circuit	5.10
Auxiliary Circuit	5.11
Accessory Circuit	5.12
Trouble Shooting	5.13
Section 6	Main Frame
Quick - Tach.....	6.1
Boom Arms	6.2
Boom Support.....	6.3
ROPS	6.4
Rear Door.....	6.5
Section 7	Engine
Maintenance.....	7.1
Cylinder Head.....	7.2
Replacement.....	7.3
Specifications.....	7.4
Trouble Shooting	7.5
Section 8	Maintenance & Specifications
Maintenance.....	8.1
Trouble Shooting	8.2
Special Tools.....	8.3
Specifications.....	8.4
Decals.....	8.5

SERIAL NUMBERS

It is important when ordering replacement parts or making a service inquiry to provide both the model number and serial number of your Thomas loader. The serial number plate is located at the rear of the machine on the left hand side hydraulic tank. In the event that the serial number plate is missing, the model number and serial number are both stamped into the main frame inside the rear door, next to the hydraulic control valve (Fig. F.1).

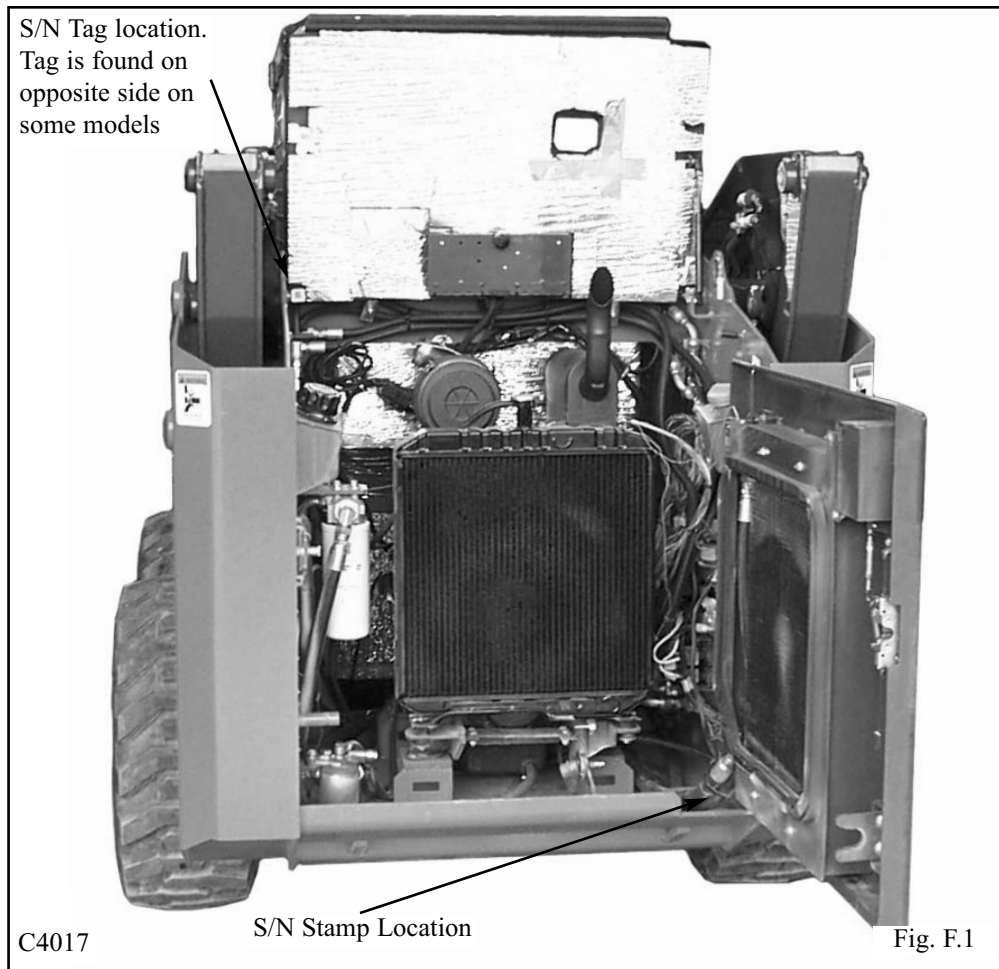

 Manufactured By
Thomas Equipment 2004 Inc.
 Centreville, N.B., Canada
 Website www.thomasloaders.com

Model #	<input type="text"/>	Cap	<input type="text"/>
Serial #	<input type="text"/>	Wt	<input type="text"/>

TH53283

 Manufactured By
Thomas Equipment 2004 Inc.
 Centreville, N.B., Canada
 Website www.thomasloaders.com

Model #	<input type="text"/>	Cap	<input type="text"/>
Serial #	<input type="text"/>	Wt	<input type="text"/>

TH53282

SAFETY PRECAUTIONS

Practically all Service work involves the need to drive the loader. The Owner's / Operator's Manual, supplied with each loader, contains safety precautions relating to driving, operating and servicing that loader. These precautions are as applicable to the service technicians as they are to the operator and should be read, understood and practiced by all personnel.

Prior to undertaking any maintenance or repair operations, make the necessary safety precautions to prevent possible personal injury to yourself, or to bystanders.

PERSONAL CONSIDERATIONS

- * **CLOTHING**
The wrong clothing or carelessness in dress can cause accidents. Check to see that you are suitably clothed. Some jobs require special protective equipment.
- * **SKIN PROTECTION**
Avoid long term contact with used motor oil. Follow work practices that minimize the amount of skin exposed and length of time used oil stays on your skin.
- * **EYE PROTECTION**
Injury can be avoided by wearing eye protection when engaged in chiseling, grinding, welding, painting and any other task that involves airborne matter.
- * **BREATHING PROTECTION**
Fumes, dust and paint spray are unpleasant and harmful. These can be avoided by wearing respiratory protection.
- * **HEARING PROTECTION**
Loud noise may damage your hearing and the longer the exposure the greater the risk of hearing damage. Always wear hearing protection when working around loud machinery.
- * **HAND PROTECTION**
It is advisable to use a protective cream before work to prevent irritation and skin contamination. After work, clean your hands with soap and water. Solvents such as white spirits, paraffin, etc. may harm the skin.
- * **FOOT PROTECTION**
Substantial or protective footwear with

reinforced toecaps will protect the feet from falling objects.

- * **SPECIAL CLOTHING**
For certain work it may be necessary to wear flame or acid resistant clothing.

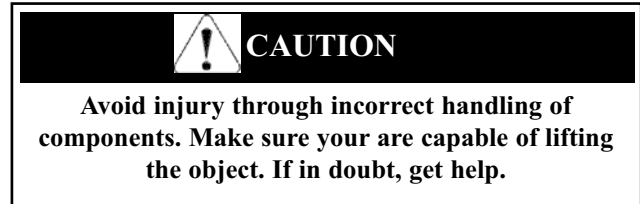

EQUIPMENT CONSIDERATIONS

- * **MACHINE GUARDS**
Before using any machine, check to ensure that the machine guards are in position and serviceable. These guards not only prevent parts of the body or clothing coming in contact with the moving parts of the machine but also ward off objects that might fly off the machine and cause injury.
- * **LIFTING APPLIANCES**
Always ensure that lifting equipment, such as chains, slings, lifting brackets, hooks and eyes are thoroughly checked before use. If in doubt, select stronger equipment. Never stand under a suspended load or raised implement.
- * **COMPRESSED AIR**
The pressure from a compressed air line is often as high as 100 psi (6.9 bar). Any misuse may cause injury.

Never use compressed air to blow dust, filing dirt, etc. away from your work area unless the correct type of nozzle is fitted.

Compressed air is not a cleaning agent. It will only move dust etc. from one place to another. Look around before using an air hose as bystanders may get grit into their eyes, ears and skin.

SAFETY PRECAUTIONS

* **HAND TOOLS**

Many cuts, abrasions and injuries are caused by defective tools. Never use the wrong tool for the job as this leads either to injury or to a poor job.

Never Use:

A hammer with a loose or split handle.

Spanners or wrenches with spread or worn jaws.

Wrenches or files as hammers, drills, clevis pins or bolts as punches.

For removing or replacing hardened pins use a copper or brass drift.

For dismantling, overhaul and assembly of major and sub-components always use the Special Service Tools recommended. These will reduce the work effort, labor time and the repair cost.

Always keep tools clean and in good working order.

* **ELECTRICITY**

Electricity has become so familiar in day to day usage that it's potentially dangerous properties are often overlooked. Misuse of electrical equipment can endanger life.

Before using any electrical equipment, particularly portable appliances, make a visual check to ensure that the cable is not worn or frayed and that the plugs, sockets etc. are intact. Make sure you know where the nearest isolating switch for your equipment is located.

GENERAL CONSIDERATIONS

* **SOLVENTS**

Use only cleaning fluids and solvents that are known to be safe. Certain types of fluids can cause damage to components such as seals, etc. and can cause skin irritation. Solvents should be checked that they are suitable not only for the cleaning of components and individual parts but also that they do not affect the personal safety of the user.

* **HOUSEKEEPING**

Many injuries result from tripping or slipping over, or on, objects or materials left lying around by a careless worker.

Prevent these accidents from occurring. If you notice a hazard, don't ignore it, remove it.

A clean hazard free place of work improves the surroundings and daily environment for everybody.

* **FIRE**

Fire has no respect for persons or property. The destruction that a fire can cause is not always fully realized. Everyone must be constantly on guard.

- Extinguish matches, cigars, cigarettes etc. before throwing them away.

- Work cleanly, disposing of waste material into proper containers.

- Locate all the fire extinguishers and ensure all personnel know how to operate them.

- Do not panic, warn those near and sound the alarm.

- Do not allow or use an open flame near the loader fuel tank, battery or component parts.

* **FIRST AID**

In the type of work that mechanics are engaged in, things such as dirt, grease, fine dust etc. all settle upon the skin and clothing. If a cut, abrasion or burn is disregarded it may be found that a septic condition has formed in a short time. What appears at first to be trivial could become painful and injurious. It only takes a few minutes to have a fresh cut dressed but it will take longer if you neglect it.

* **CLEANLINESS**

Cleanliness of the loader hydraulic system is essential for optimum performance. When carrying out service and repairs, plug all hose ends and components connections to prevent dirt entry.

Clean the exterior of all components before carrying out any form of repair. Dirt and abrasive dust can reduce the efficiency and working life of a component and lead to costly replacement. Use of a high pressure washer or steam cleaner is recommended.

SAFETY PRECAUTIONS

OPERATIONAL CONSIDERATIONS

- * Stop the engine, if at all possible, before performing any service.
- * Place a warning sign on loaders which, due to service or overhaul, would be dangerous to start. Disconnect the battery leads if leaving such a unit unattended.
- * Do not attempt to start the engine while standing beside the loader or attempt to bypass the safety starting system.
- * Avoid prolonged running of the engine in a closed building or in an area with inadequate ventilation as exhaust fumes are highly toxic.
- * Always turn the radiator cap to the first stop to allow pressure in the system to dissipate when the coolant is hot.
- * Never work beneath a loader which is on soft ground. Always take the unit to an area which has a hard working surface, preferably concrete.
- * If it is found necessary to raise the loader for ease of maintenance, make sure that safe and stable supports are installed beneath the main frame before commencing work.
- * Use footsteps or working platforms when servicing those areas of the loader that are not within easy reach.
- * Before loosening any hoses or tubes, switch off the engine, remove all pressure in the lines by operating the foot pedals several times. This will remove the danger of personal injury by oil pressure.
- * Prior to pressure testing, make sure all the hoses and connectors on both the loader and on the test machine are in good condition and tightly sealed. Pressure readings must be taken with the gauges specified. The correct procedure should be rigidly observed to prevent damage to the system or the equipment and to eliminate the possibility of personal injury.
- * To avoid personal injury, service the loader with the arms down and the bucket or attachment on the ground. If it is necessary to service the loader with the boom arms raised, be sure to engage the boom supports. Never work under or around a loader with raised boom arms without boom supports engaged.
- * If high lift attachments are installed on a loader, beware of overhead power and telephone lines when travelling. Drop attachment near to ground level to increase stability and minimize risks.
- * Do not park or attempt to service a loader on an incline. If unavoidable, take extra care and block the wheels.
- * Escaping hydraulic / diesel fluid under pressure can penetrate the skin causing serious injury. Do not use your hand to check for leaks. Use a piece of cardboard or paper to search for leaks. Stop the engine and relieve pressure before connecting or disconnecting lines. Tighten all connections before starting the engine or pressurizing the lines. If any fluid is injected into the skin, obtain medical attention immediately.
- * Prior to removing wheels and tires from a loader, check to determine whether additional ballast (liquid or weight) has been added. Seek assistance and use suitable equipment to support the weight of the wheel assembly.
- * When inflating tires beware of over inflation; constantly check the pressure. Over inflation can cause tires to burst and result in personal injury.
- * Safety precautions are very seldom the figment of someone's imagination. They are the result of sad experience where most likely someone has paid dearly through personal injury.
- * Heed these precautions and you will protect yourself accordingly. Disregard them and you will duplicate the sad experiences of others.

SAFETY PRECAUTIONS

SERVICE TECHNIQUES

A. SERVICE SAFETY

Appropriate service methods and proper repair procedures are essential for the safe, reliable operation of all motor vehicles as well as the personal safety of the individual doing the work. This shop manual provides general directions for accomplishing service and repair work with tested effective techniques. Following them will help assure reliability. There are numerous variations in procedures, techniques, tools and parts for servicing vehicles as well as in the skill of the individual doing the work. This manual cannot possibly anticipate all such variations and provide advice or cautions as to each. Accordingly, anyone who departs from the instructions provided in this manual must first establish that he or she compromises neither his personal safety nor the vehicle integrity by his choice of methods, tools or parts.

B. SERVICE TECHNIQUES

Clean the exterior of all components before carrying out any form of repair. Dirt and abrasive dust can reduce the efficient working life of a component and lead to costly replacement.

Use cleaning fluids which are known to be safe. Certain types of fluid can cause damage to O-rings and cause skin irritation. Solvents should be checked that they are suitable for the cleaning of components and also that they do not risk the personal safety of the user.

Time spent on the preparation and cleanliness of working surfaces will pay dividends in making the job easier and safer and will result in overhauled components being more reliable and efficient in operation.

Replace O rings, seals or gaskets whenever they are disturbed. Never mix new and old seals and O rings, regardless of condition. Always lubricate new seals and O rings with hydraulic oil before installation.

When replacing component parts use the correct tool for the job.

C. HOSES AND TUBES

Always replace hoses and tubes if the end connections are damaged. Be sure any hose installed is not kinked or twisted.

When installing a new hose, loosely connect each end and make sure the hose takes up the designed position before tightening the connection. Clamps should be tightened sufficiently to hold the hose without crushing and to prevent chafing.

The hoses are the arteries of the unit. Be sure they are in good condition when carrying out repairs or maintenance. Otherwise the machines output and productivity may be affected.

After hose replacement to a moving component, check that the hose does not foul by moving the component through the complete range of travel.

Hose connections which are damaged, dented, crushed or leaking, restrict oil flow and the productivity of the components being served. Connectors which show signs of movement from the original swaged position have failed and will ultimately separate completely.

A hose with a chafed outer cover will allow water entry. Concealed corrosion of the wire reinforcement will subsequently occur along the hose length with resultant hose failure.

Ballooning of the hose indicates an internal leakage due to structural failure. This condition rapidly deteriorates and total hose failure soon occurs.

Kinked, crushed, stretched or deformed hoses generally suffer internal structural damage which results in oil restriction, a reduction in the speed of operation and ultimate hose failure.

Free moving, unsupported hoses must never be allowed to touch each other or related working surfaces. This causes chafing which reduces hose life.

D. PRESSURE TESTING

Prior to pressure testing, be sure all hoses are in good condition and all connections tight. Pressure readings must be taken with gauges of specified pressure readings.

The correct procedure should be rigidly observed to prevent damage to the system or the equipment and to eliminate the possibility of personal injury.

SAFETY PRECAUTIONS

E. BEARINGS

Bearings which are considered suitable for further service should be cleaned in a suitable solvent and immersed in clean lubricating oil until required.

Installation of a bearing can be classified into two (2) ways:

- press fit on rotating parts such as shafts and gears,
- push fit into static locations such as reduction gear houses.

Where possible, always install the bearing onto the rotating components first. Use the correct tools or a press to install a bearing or bushing. In the absence of the correct tools or press, heat the bearing and / or casing in hot oil to assist the installation of the bearing.

When bearings or bushings are removed, always carefully check that the bearing is free from discoloration and signs of overheating. Also check for mechanical damage such as excessive clearance, nicks and scuffing. If in doubt, replace the bearings or bushings.

Bearings should never be removed unless absolutely necessary. Always use the recommended puller to reduce the risk of bearing or related component failure.

These bearings and bushings are subjected, in normal operation, to high working loads and adverse conditions.

Be sure during normal routine servicing, maintenance or repair that bearings are given the right attention and are installed with care.

F. BOOM SUPPORTS

For safety while performing regular service or maintenance work, the loader is equipped with boom supports.

The boom supports, when extended, prevent the boom arms from dropping if hydraulic pressure is relieved or the foot control pedals are accidentally cycled.

To operate the boom supports, first remove any bucket or attachment from the quick - tach; raise the boom arms to full height and shut off the engine. Raise the boom handles up and push out toward the boom arms to extend the boom supports (Fig. F.2 & Fig. F.3).

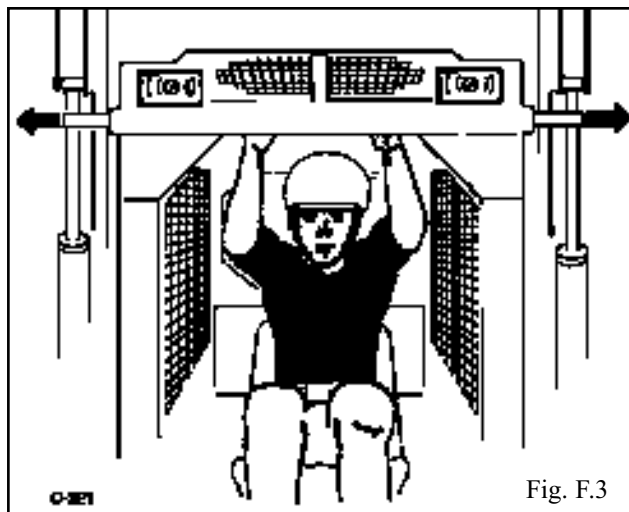
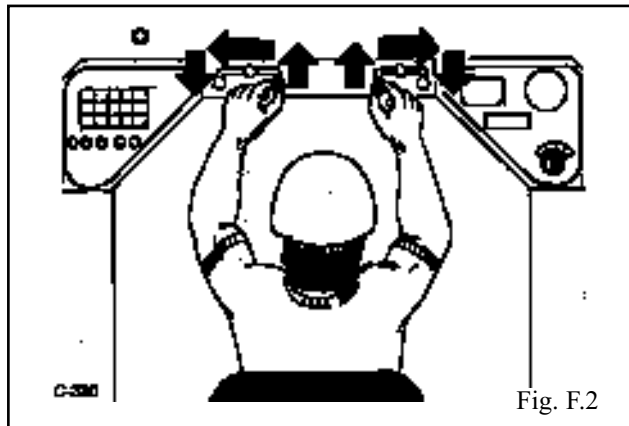

WARNING

To avoid personal injury, service the loader with the arms down and the bucket or attachment on the ground. If it is necessary to service the loader with the boom arms raised be sure to engage the boom supports. Never work under or around a loader with raised boom arms without boom supports engaged.

SERVICE ACCESS

1. Lift Arm Support

For safety while performing regular service or maintenance work, the loader is equipped with lift arm support pins. The lift arm support pins when extended prevent the lift arms from dropping if hydraulic pressure is relieved or the hydraulic controls are accidentally cycled.

To operate the lift arm support, first remove any bucket or attachment from the quick-tach; raise the lift arms to full height. Raise the lift arm support handle (Fig. F.4) up and push out toward lift arms to extend the lift arm supports. (Fig. F.5) Slowly lower the lift arms down on to the pins. To retract the lift arm supports, lift the lift arms off of the pins before retracting pins.



2. Seat/Front Bulkhead Removal

The seat assembly and front bulkhead assembly can be removed to provide access to the controls, hydraulic and hydrostatic components.

To remove the seat assembly, remove the fastener located at the front of the seat. **DISCONNECT ELECTRICAL PLUG!** Lift the seat assembly out of the machine. When installing the seat, be sure the seat plate is locked in place at the rear (Fig. F.6).

To remove front bulkhead assembly, remove the fasteners at either side and lift out. Installation is the reverse procedure (Fig. F.7).

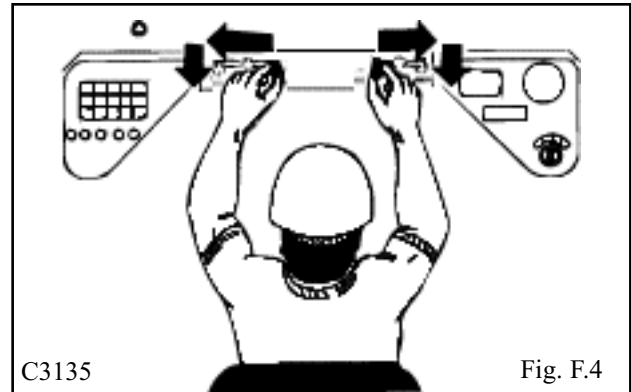

Fig. F.4

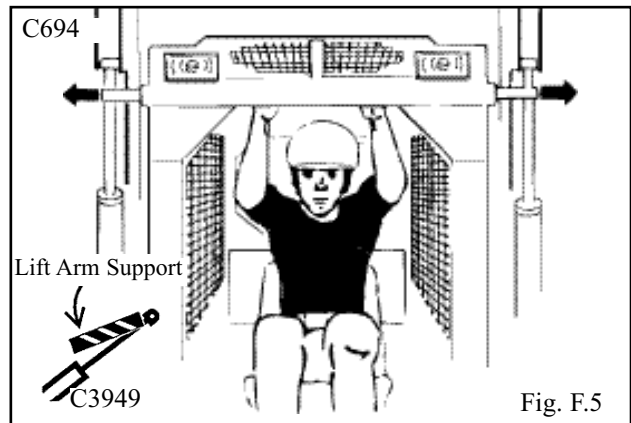

Fig. F.5

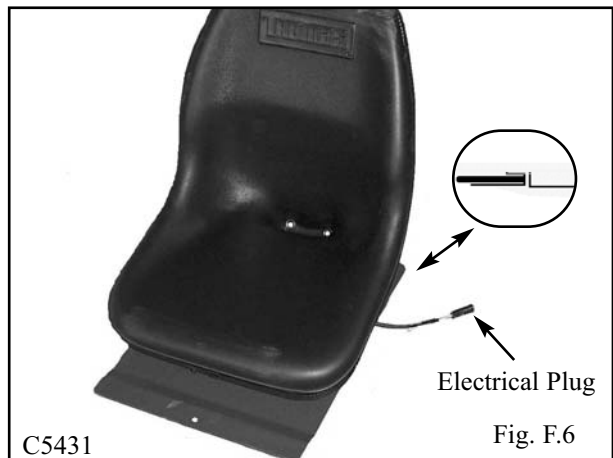

Fig. F.6

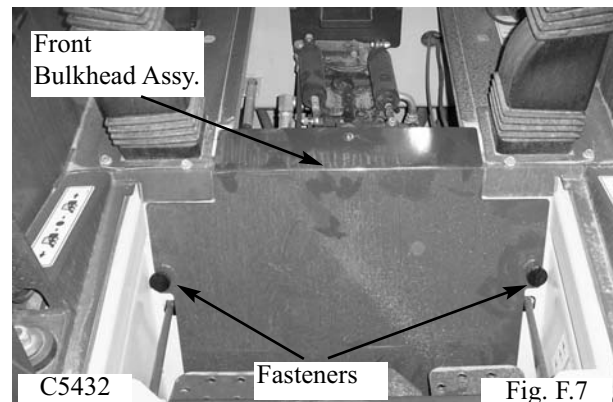
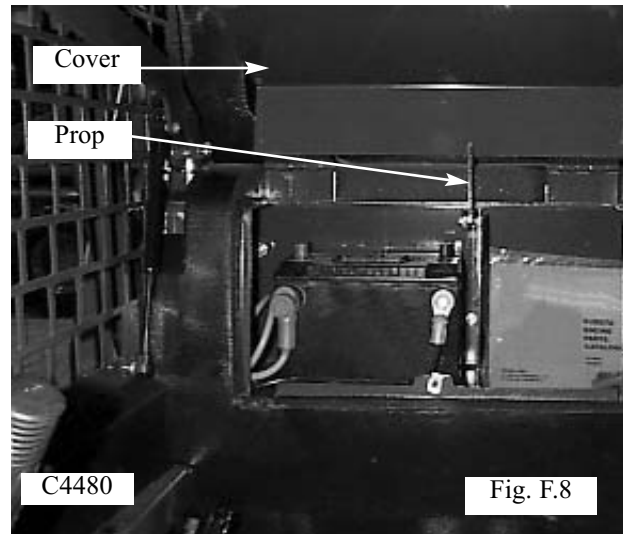

Fig. F.7

SERVICE ACCESS, contd.

3. Battery Access

The battery is located in a compartment found behind the operators seat (Fig. F.8). Remove the seat and remove the bolt holding the battery cover in place. The battery compartment is hinged with a prop rod to hold open.



4. Engine Compartment

The engine compartment is completely enclosed for component protection and lockable to discourage vandalism. For servicing, the rear door swings open and the engine cover hinges up (Fig. F.9).

To open, reach through the opening in the rear door (Fig. F.9), and pull outward releasing the door latch. (Fig. F.10). Always remember to lower the engine cover before closing the rear door.

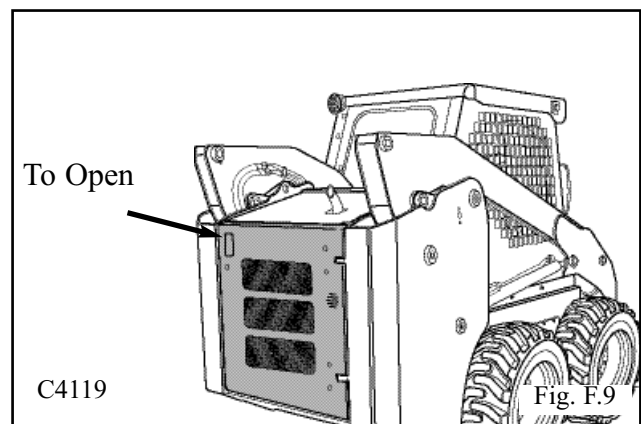

IMPORTANT	<p>Keep the rear door closed except for servicing. Make sure the door is closed and latched before operating the loader.</p>
------------------	---

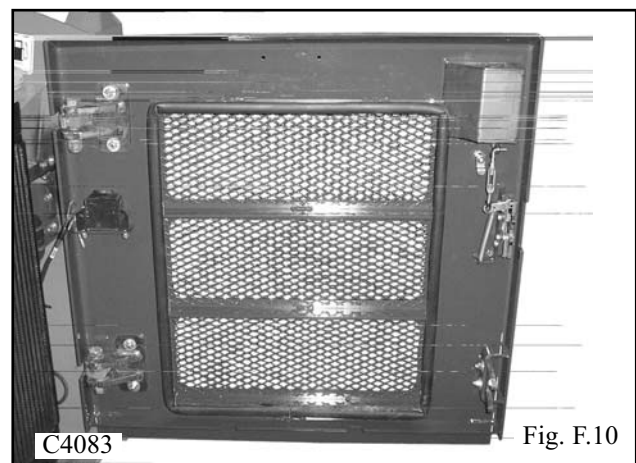

SECTION 1 HYDRAULIC SYSTEM

Hydraulic Circuit	1.1
Layout	pg. 1-2
Schematic	pg. 1-3
Specifications	pg. 1-4
Maintenance Schedule	pg. 1-4
Gear Pump	1.2
General Information	pg. 1-5
Replacing the Gear Pump	pg. 1-6
Gear Pump Disassembly	pg. 1-7 ~ 11
Gear Pump Reassembly	pg. 1-12 ~ 14
Control Valve	1.3
Testing / Adjusting the Relief Valve	pg. 1-15 ~ 16
Control Valve Replacement	pg. 1-16 ~ 17
Exploded Illustration Diagram	pg. 1-18
Control Valve Disassembly / Repair	pg. 1-19 ~ 24
Hydraulic Cylinders	1.4
General Information	pg. 1-25
Lift Cylinder Removal	pg. 1-27
Tilt Cylinder Removal	pg. 1-28
Testing Piston Seals	pg. 1-26
Cylinder Disassembly	pg. 1-29 ~ 30
Cylinder Inspection	pg. 1-31
Cylinder Assembly	pg. 1-31 ~ 32
Hydraulic Oil Filter	1.5
General Information	pg. 1-33
Filter Replacement	pg. 1-33
Hydraulic Oil Cooler	1.6
General Information	pg. 1-34
Oil Cooler Replacement	pg. 1-35
Hydraulic Oil Reservoir	1.7
General Information	pg. 1-36
Checking the Oil Level	pg. 1-36
Adding Oil	pg. 1-36
Servicing the Reservoir	pg. 1-37
Trouble Shooting	1.8
Trouble Shooting Chart	pg. 1-38 ~ 39
Torque Chart	1.9
Torque Chart	pg. 1~39
Conversion Charts	1.10
Conversion Charts	pg. 1-40 ~ 41

HYDRAULIC CIRCUIT 1.1

1

205 Hydraulic Layout

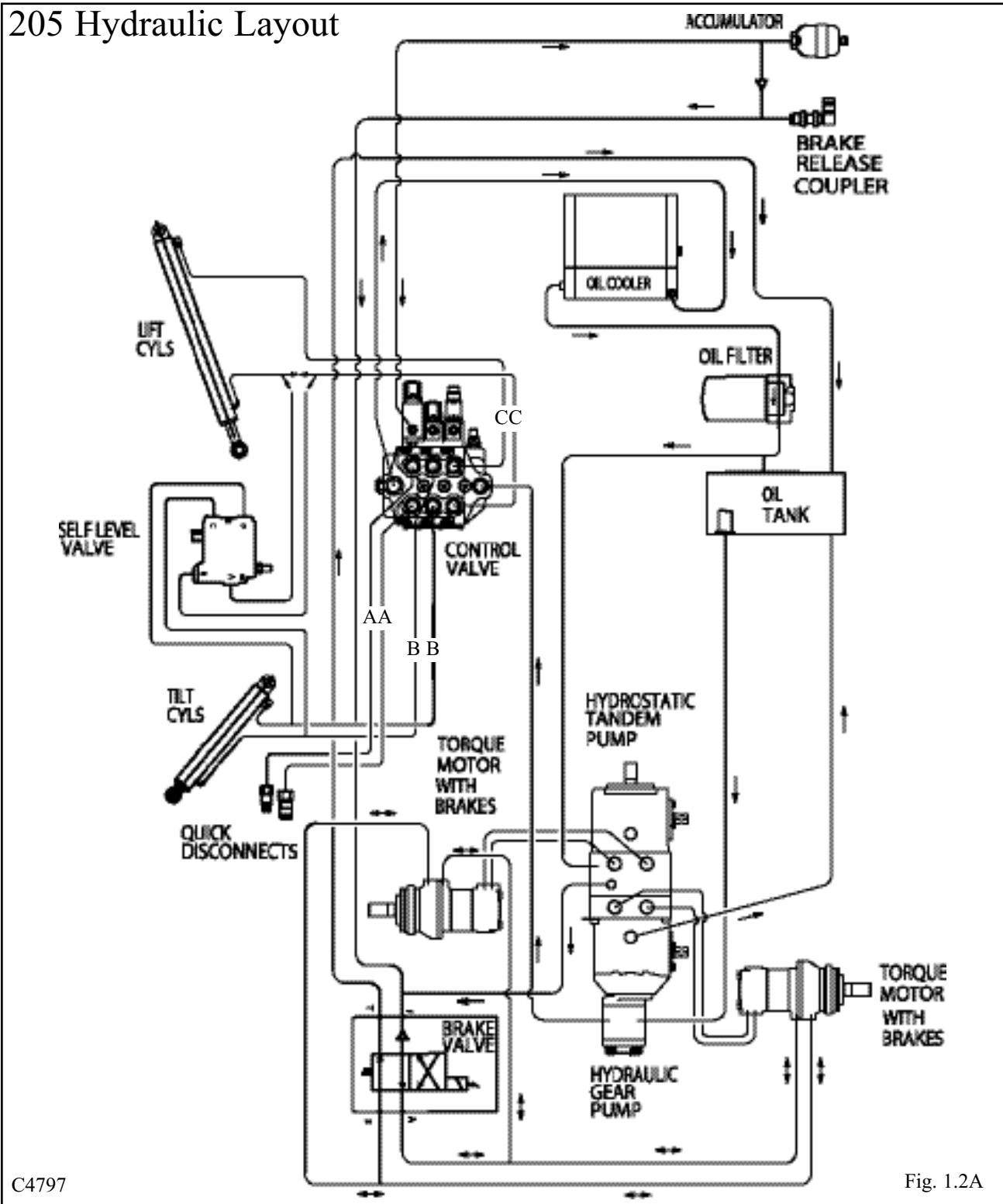

C4797

Fig. 1.2A

- A Auxiliary Circuit
- B Tilt Circuit
- C Lift Circuit

HYDRAULIC CIRCUIT 1.1

1

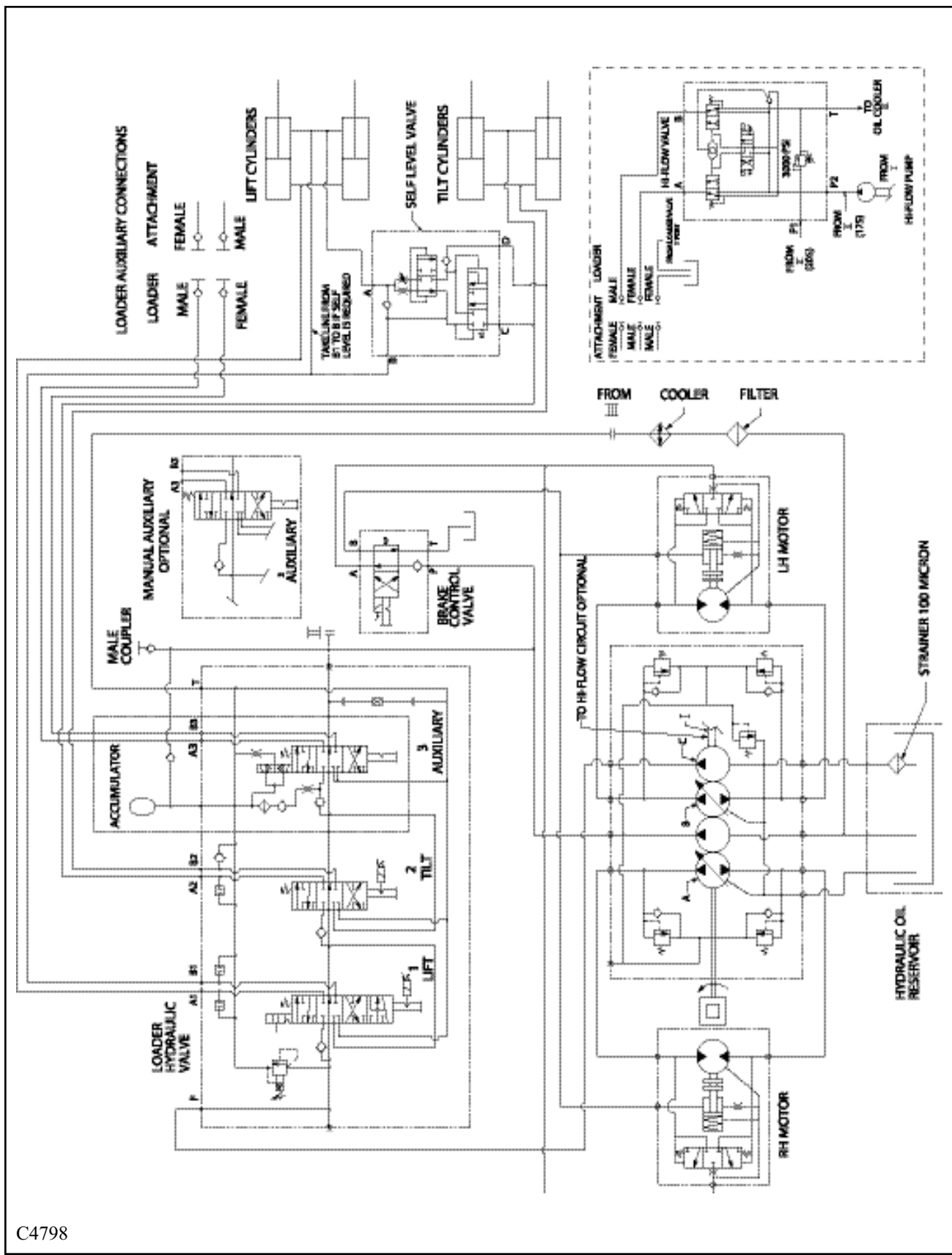

C4798

HYDRAULIC CIRCUIT 1.1

1

Hydraulic Specifications

Pump Type	Gear, 1.77 cu in (29 cc)
Pump Brand	Sauer Danfoss
Pump Capacity	21 gal/min (79.6 l/min)
Control Valve	Series Type
Main Relief Pressure	3000 psi (206.8 bar) @ Zero Flow
Reservoir Capacity	17.4 US gallons (66 liters)
Fluid Type	10W30 API SJ Oil
Reservoir Filtration	100 Micron
System Filtration	5 Micron
Oil Cooler	880 BTU

205

Cylinders	Lift	Tilt
Qty per Loader	2	2
Bore Dia	2.5 in.	2.5 in.
Rod Dia	1.5 in.	1.5 in.
Stroke	42.5 in.	15.5 in.
Cycle Times	5.39 Up	1.5 Up
.....	3.5 Dn	2.0 Dn

Allowable Drop, Measured at the Cylinder Rod, Engine Off,
 @ Rated Capacity and Operating Temperature 1.5" (38mm) / 3 Minutes

Maintenance Schedule	First (HRS)	Every (HRS)
Oil level check	8	8
Oil filter change	50	150
Oil cooler clean	8	8
General system check (leaks etc.)	8	8
Cylinders, lubricate	8	8
Control valve relief filter	500	1000
Reservoir filters change	1000	1000
Hydraulic oil change	1000	1000

GEAR PUMP 1.2

General Information

Refer to Fig. 1.2A on page 1-2.

Oil is drawn from the hydraulic oil reservoir through a 100 micron element. From there it travels to the main hydraulic pump.

- The hydraulic pump is a gear type which is coupled through the hydrostatic drive pump at engine speed. The oil then flows from the gear pump to the hydraulic control valve.

- The hydraulic control valve is equipped with an adjustable relief valve which is adjusted to 3000 psi (206.8 bar). The control valve is a series type with 3 spools (banks). The various spools activate the boom, bucket and auxiliary hydraulic functions.

When the spools are in neutral, oil flows from the hydraulic gear pump, through the control valve and returns to the hydraulic cooler, to the 5 micron hydraulic filter. From the hydraulic filter, the fluid flows to charge the tandem hydrostatic pump and pressurize the hydraulic brake release system and then back to the hydraulic reservoir. As a spool is moved, oil is directed to one of the valve ports and oil flows out to operate a function. The return oil coming back from this operation is ported to the next valve section which allows operation of more than 1 function at the same time. This is a series type valve function.

Each spool end contains a centering spring which returns the spool to neutral when the foot pedal, or control handle, is released.

- The boom section, on foot control operated loaders, has a detent mechanism to hold the spool in the float position. The auxiliary section is operated by foot pedal operation, or may have an optional electrical solenoid operated control, and may be engaged momentarily by the control lever mounted switch, forward or reverse, or by engaging the dash mounted toggle switch for constant power in the forward direction only.

The system relief valve operates when ever a hydraulic function has been restricted or overloaded (Fig. 1.2D). To protect against excessive pressure build up, the relief valve opens and allows oil to return to the return outlet. The system relief valve is adjustable, and is preset at 3000 psi. (206.8 bar)

- Load check valves are located between the ports of each spool circuit. The function of the load check valve is to hold the boom arms or bucket in position during initial spool movement (Fig. 1.2E).

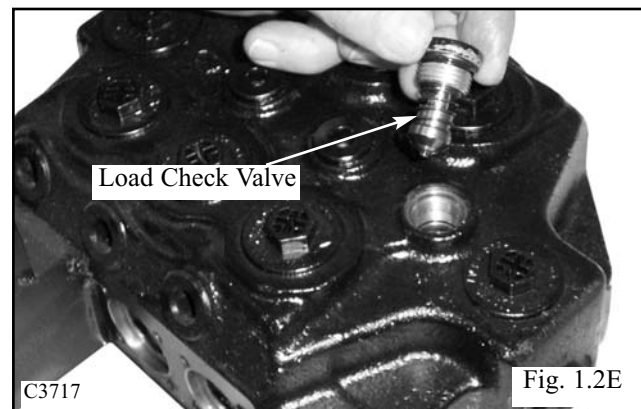
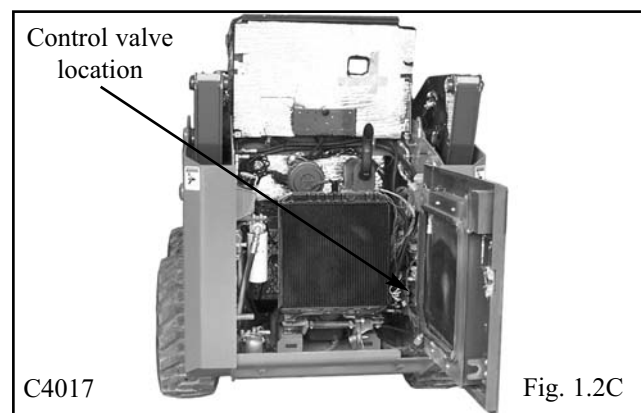
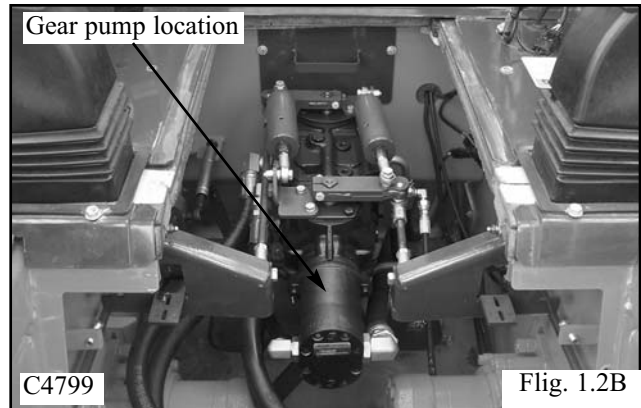

GEAR PUMP 1.2

1

Replacement

Start the gear pump removal procedure by removing any attachment, raising the boom arms and engaging the boom support pins. Shut off the engine.



WARNING

To prevent personal injury do not work under the boom arms without the boom supports engaged.

- 1 Remove the seat and hydrostatic shield (pg. 11).
- 2 Attach a vacuum system to the hydraulic oil reservoir filler location. (Fig. 1.2F) Drain the oil reservoir if a vacuum is not available. If the drain plug is removed, seal the threads with teflon tape or a liquid form of pipe sealant before reinstalling.
- 3 Disconnect the hydraulic hoses from the gear pump. (Fig. 1.2g) Remove the pump fittings. Cap all open hoses to prevent contamination. After capping all ends, you may unhook vacuum system from oil reservoir.
- 4 Remove the 2 bolts holding the gear pump to the hydrostatic tandem section. (Fig. 1.2H) Remove the gear pump.
- 5 Inspect the drive coupler for signs of wear and replace if required. Install a new O-ring on the seal area of the new gear pump unit.

IMPORTANT

If gear pump replacement is being done because of failure, the hydraulic system and oil should be checked for contamination.

- 6 Replace gear pump in reverse order. Torque the mounting bolts to 30 ft lbs (41Nm)
- 7 If the hydraulic system has been contaminated by the pump or other failure you must follow the cleaning procedure outlined in section 2.6.



WARNING

Use caution when dealing with hydraulic fluid under pressure. Escaping fluid under pressure can penetrate the skin and cause serious injury.

- 8 Start the engine and check for leaks. Do not use your hands to find leaks.
- 9 Check the fluid level in the hydraulic oil reservoir and replenish as required. (Fig. 1.2I)

IMPORTANT

When making repairs to the hydraulic system, keep the work area and parts clean. Use caps and plugs on all open lines and ports.

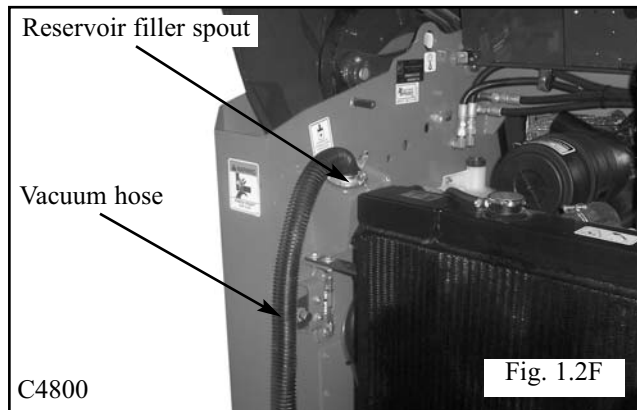

C4800

Fig. 1.2F

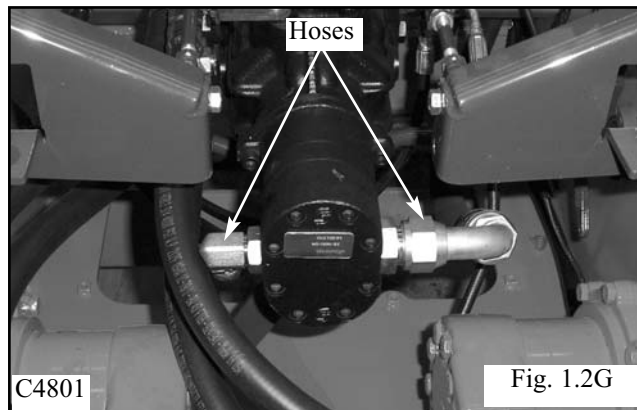

C4801

Fig. 1.2G

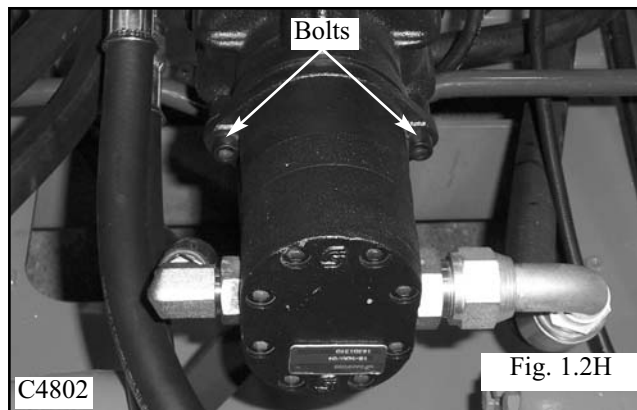

C4802

Fig. 1.2H

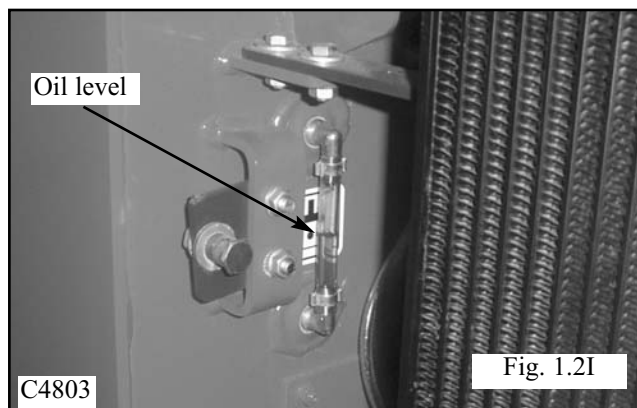

C4803

Fig. 1.2I

GEAR PUMP 1.2

1

Disassembly

1. General

The following is a detailed procedure for the disassembly and assembly of the gear pump. Prior to proceeding it may be necessary to prepare some sub-assembly separately. The details for preparing each sub-assembly are given in the following section, as well as some general recommendations.

2. Cleanliness

Cleanliness is the primary factor for reliable pump performance. Wash the outside of the pump thoroughly before disassembly and all pieces prior to assembly. Cleaning parts with clean shop solvent and air drying is usually adequate.

3. Lubrication Of Moving Parts

During assembly, it is imperative to provide lubrication with clean hydraulic oil to all the running parts of the pump. It is also necessary to coat the seals with grease. The absence of lubrication during assembly can cause the unit to seize after a few minutes of running.

4. Care Of Surface Treatment

Be careful when handling all the internal surfaces, especially bearings, gears, and body faces. Do not touch or score them with metal tools or cutting edges.

5. Marking The Parts

Mark the parts before completely disassembling a pump. The marks allow components to be reassembled in the same relative position. This action should be applied to the body, bearings, and gears. Scribing, bluing, or using a felt pen to mark the outside of the body on the inlet side is suggested to indicate the relative position of the front flange and the rear cover to the body. DO NOT scribe internal surfaces.

IMPORTANT

Mark all pieces during disassembly so that the unit can be reassembled correctly. Installing components incorrectly could severely damage the unit and/or cause it to not function properly.

GEAR PUMP 1.2

1

Disassembly 205

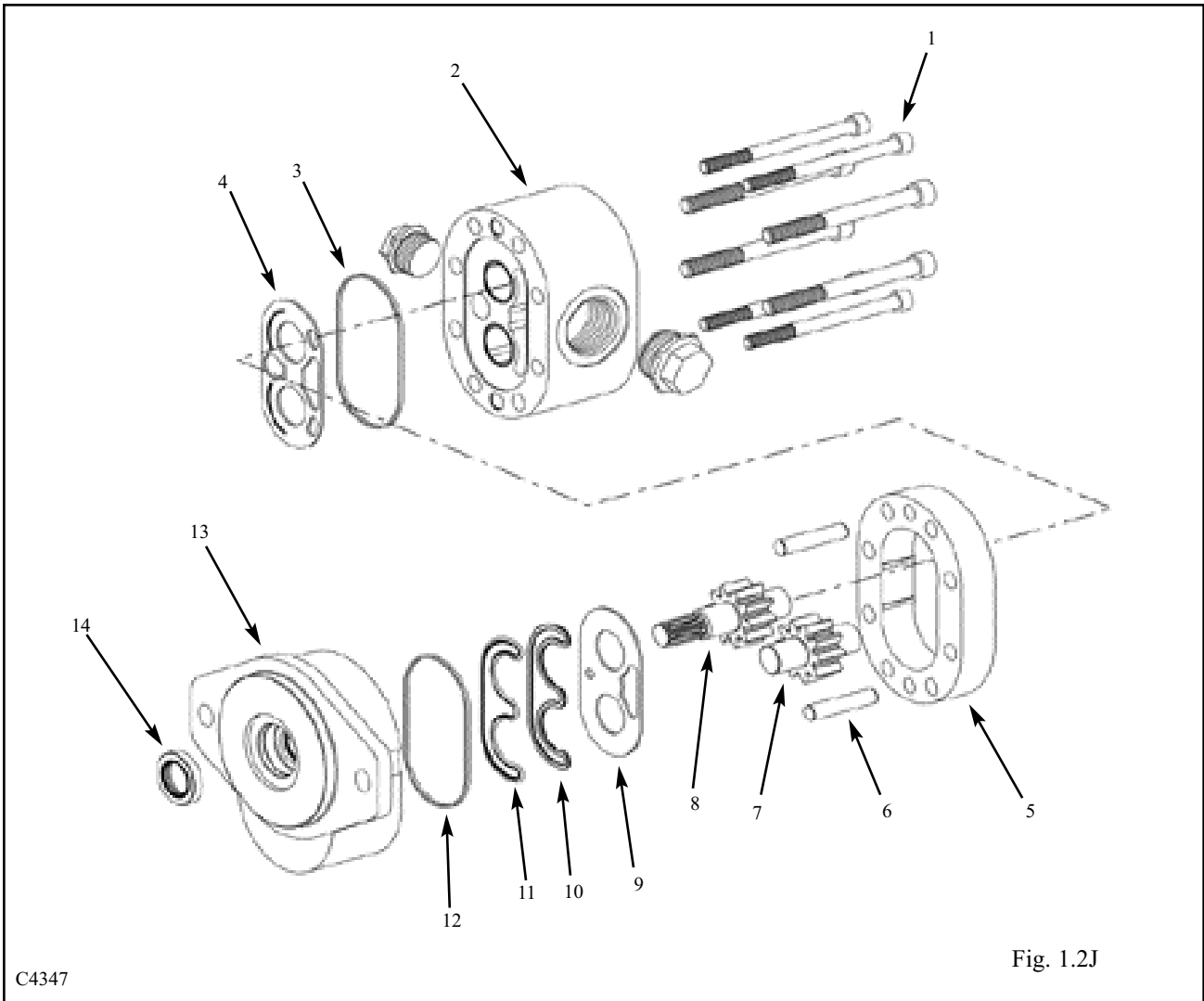

Fig. 1.2J

C4347

- | | |
|-------------------|-------------------|
| 1. Screws | 8. Drive Shaft |
| 2. Cover Assembly | 9. Wear Plate |
| 3. Seal Ring | 10. Load Ring |
| 4. Wear Plate | 11. Preload Ring |
| 5. Gear Plate | 12. Seal Ring |
| 6. Dowel Pin | 13. Body Assembly |
| 7. Idler Shaft | 14. Shaft Seal |

GEAR PUMP 1.2

1

Disassembly 205

6. Procedure

1. Clamp the unit in a vice from the flange side (Fig. 1.2K). Make sure the vice jaws are clean and have smooth surfaces to prevent damage to the pump. Caution must be used when using a vice to avoid distorting any parts or damaging the mounting pilot.

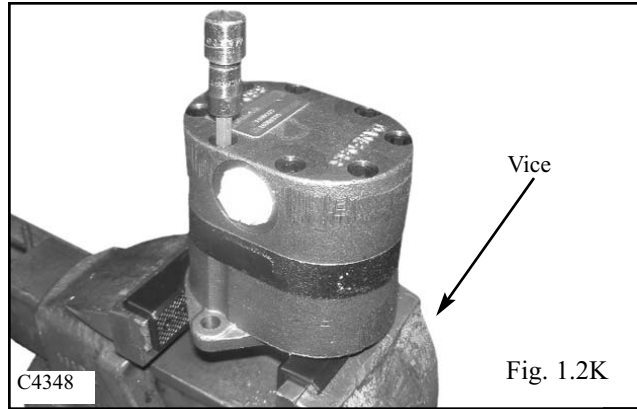

2. Use a Allen head socket wrench to loosen the bolts on the cover assembly (Fig. 1.2L). Next completely unscrew the bolts and remove them. Inspect the threads for damage (Fig. 1.2M).

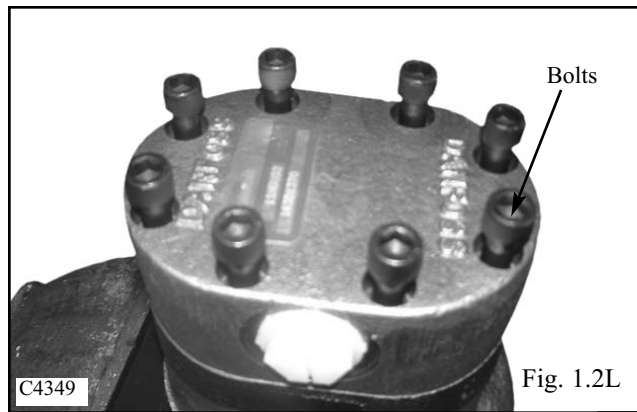

3. Slowly remove the cover assembly (Fig. 1.2N). Note, some units have a shaft seal and others do not. Should your unit have the shaft seal, be careful not to damage it when removing the cover assembly.

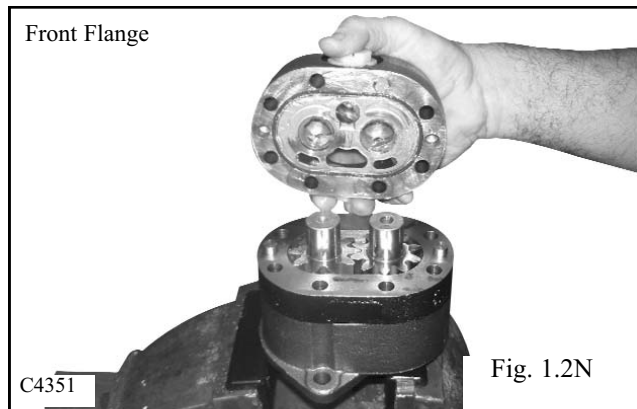
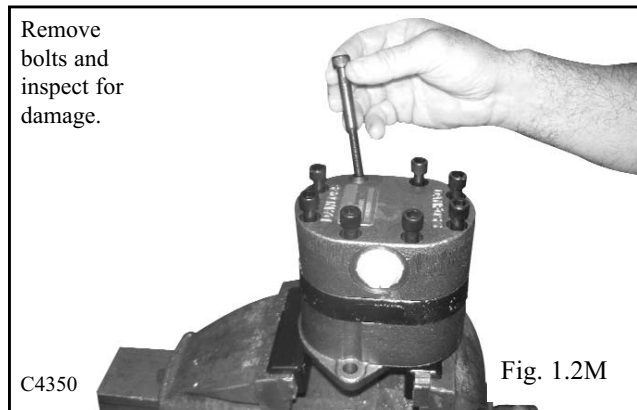

GEAR PUMP 1.2

1

Disassembly 205 (cont'd)

6. Procedure

4. Place the cover assembly on the work bench (Fig. 1.2O). Inspect the wear plate for evidence of extrusion or marks caused by overheating. Replace if necessary. Remove the wear plate and seal ring on the cover assembly. Do not use tools with sharp edges to remove the seal, as damage to the housing may result.

5. While disassembling the unit, you need to mark the relative positions of the gear mesh (drive gear tooth and idler gear tooth) and the body so they can be reassembled in the same position. Carefully remove the gear plate (Fig. 1.2P). Remove the dowel pins and place in the gear plate.

6. Remove the idler shaft (Fig. 1.2Q) and drive shaft (Fig. 1.2R) from its bearing bore. Inspect the journals and the flat faces top and bottom of the gears. Ensure these surfaces are free from burrs or scratches. If scratches are found, clean them with a flat stone and/or a very fine emery cloth. Rewash the gears with light oil after this operation.

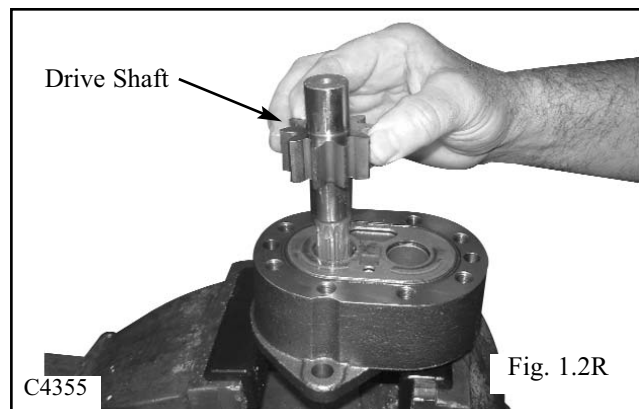
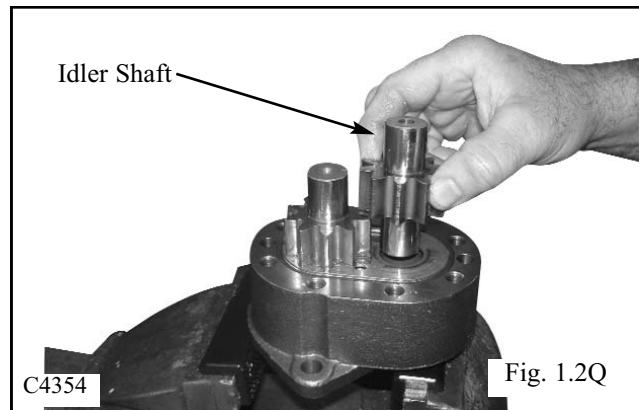
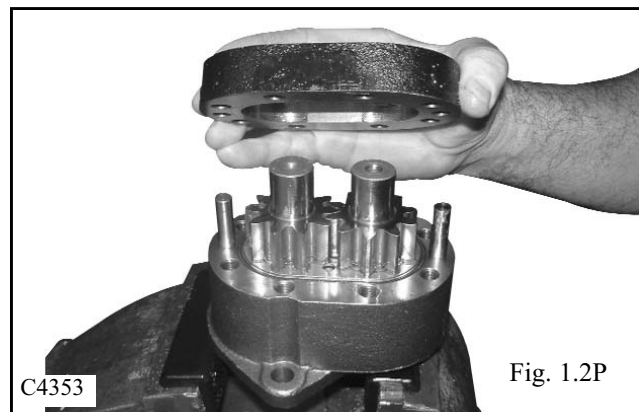
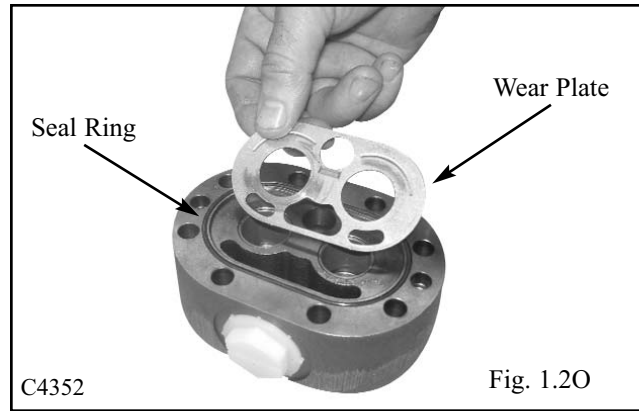

GEAR PUMP 1.2

1

Disassembly 205 (cont'd)

6. Procedure

7. Inspect the wear plate for evidence of extrusion, or marks caused by overheating. Remove the wear plate from the body assembly. (Fig 1.2S) Replace if necessary. Remove the load ring, pre-load ring and seal ring. (Fig 1.2T) Do not use tools with sharp edges to remove the seals, as damage to the housing may result. Dispose of any damaged seals.

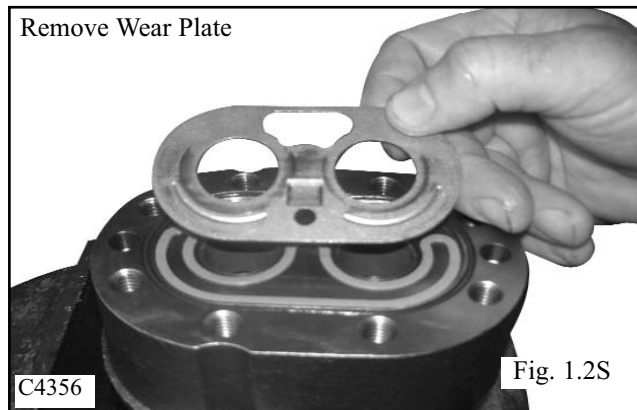

8. Remove the shaft seal in the body assembly (if applicable). Place the flange on the work surface. Using internal snap ring pliers, remove the snap ring. Check the seal quality and remove it if necessary. To remove, pry the bottom of the shaft seal and force it out while rotating the flange to lift it out evenly. Do not use the flange pilot to gain leverage as damage may result. Use a plastic rod or wooden dowel as a fulcrum. After removal, dispose of the damaged seal.

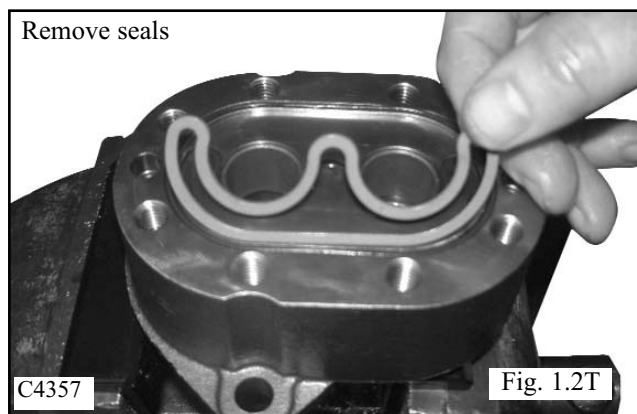

9. Complete disassembled unit. (Fig. 1.2U)

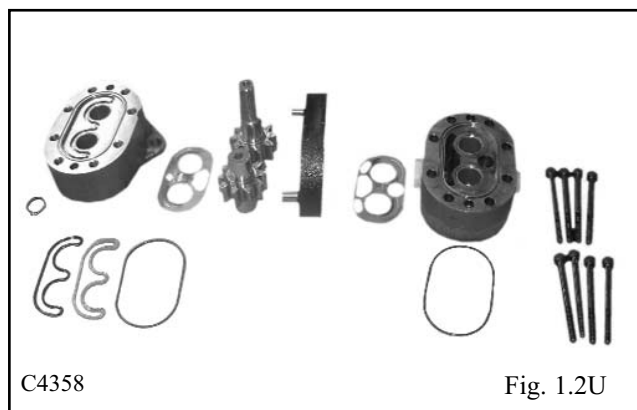

GEAR PUMP 1.2

1

Assembly 205

1. Have the entire seal kit available and layed out neatly on the table (Fig. 1.2V). Compare the old seal kit to the new one to ensure you have the correct one. Lightly coat all seals with seal grease. The grease is needed to adhere the seals in their grooves. **DO NOT INSTALL DRY SEALS!**

2. Prepare the body by cleaning it. Inspect the internal and mating surfaces. Ensure the surfaces are free of burrs and scratches.

3. Install the shaft seal into the body assembly (if applicable). Prepare the body and shaft seal by lightly lubricating with grease. Seat the seal in the body assembly by hand. Then, using a shaft seal installation tool press the seal until the tool stops on the flange. This will insure the seal is inserted to the proper depth.

3. Place the body assembly, with the E- ring seal grooves facing up, into a vice with soft jaws. Caution must be used when using a vice to avoid distorting or damaging the mounting pilot.

4. Place the rubber seal ring in the body groove. (Fig. 1.2W)

5. Place the pre-load seal (black rubber E-ring) into the body E-ring groove. (Fig. 1.2X)

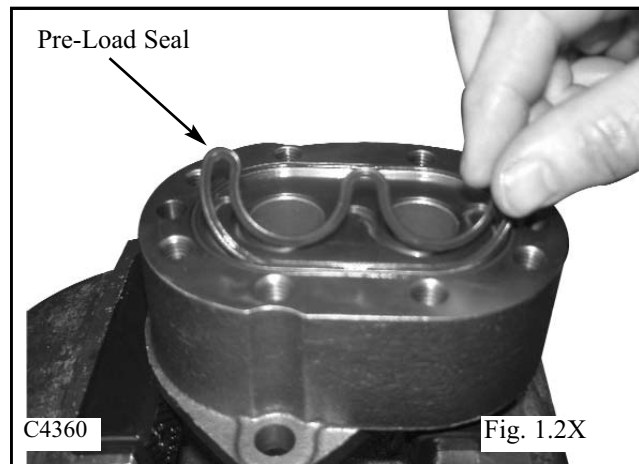
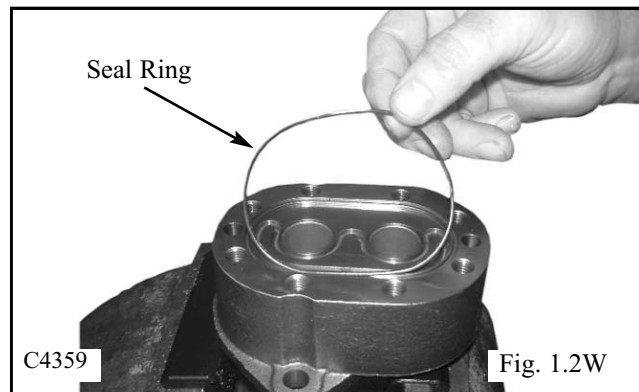
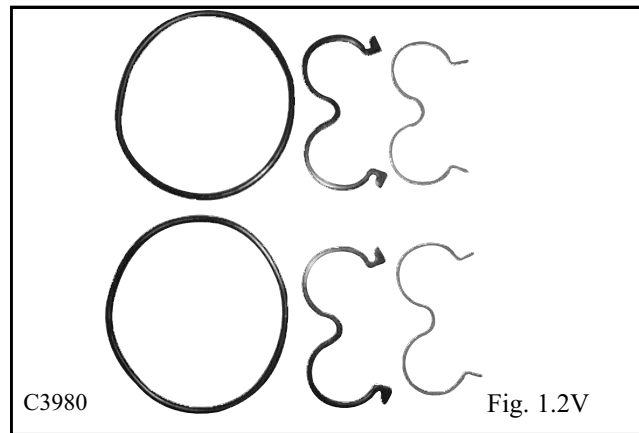

GEAR PUMP 1.2

1

Assembly 205 (cont'd)

6. Place the load seal directly on top of the pre-load seal (blue E-ring).

7. Find the wear plate with a 0.25" diameter pressure hole and No oblong holes on the inlet side. Place the wear plate on top of the load ring with the bronze side facing up towards the gears. The 0.25" pressure hole is to be positioned on the E-ring side of the body. (Fig 1.2Y)

8. Lubricate the spline end of the drive shaft with Aerolube grease. Insert the drive shaft in the correct bearing bore. Align the idler shaft with the assembly marks to ensure assembly is installed with the same orientation as before assembly. Place the idler shaft in the correct bearing bore into the body (Fig. 1.2Z). Inspect gear teeth for alignment. Misaligned gear teeth may increase operating noise. Lubricate the complete gearset using clean light oil.

9. Insert the two dowel pins into the body assembly. Place the gear plate over the dowel pins and lightly tap making sure it contacts the body. (Fig. 1.2AA) Check to make sure the gear plate is seated properly with no foreign material pinched between these surfaces (Fig. 1.2BB).

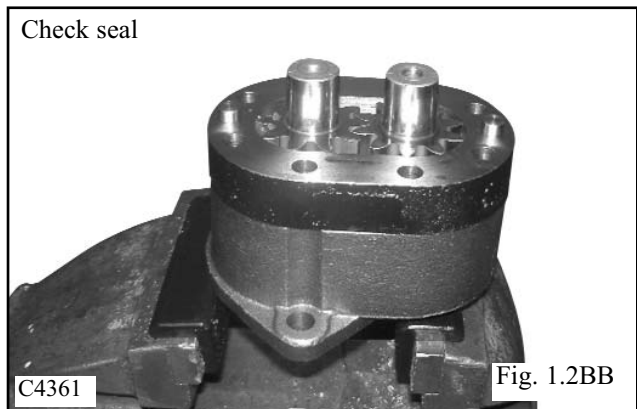
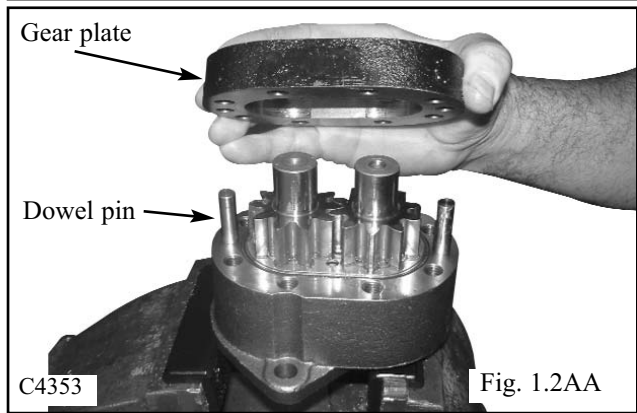
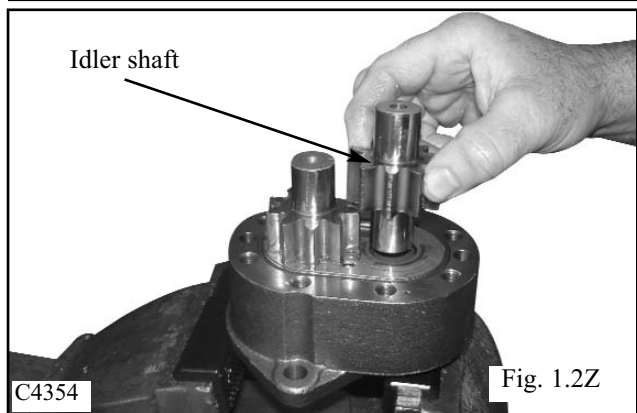
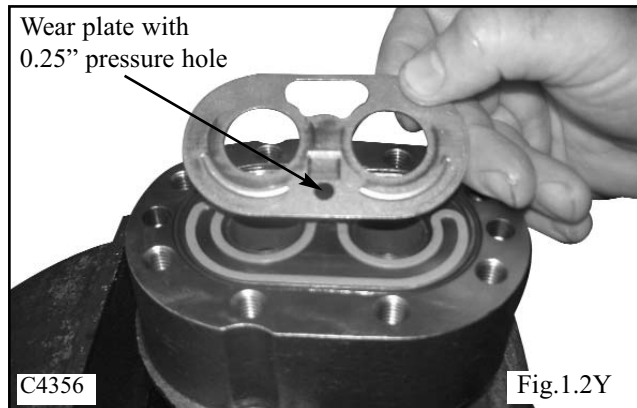

GEAR PUMP 1.2

1

Assembly 205 (cont'd)

10. Place the cover assembly on a bench with the machined surface facing up. Place the rubber seal ring in the cover seal ring groove. (Fig. 1.2CC)

11. Find the wear plate with the 0.625" diameter pressure hole and two oblong holes on the inlet side. Position the wear plate in the cover with the bronze side facing up (towards gears) and the 0.625" pressure hole located over the circular holes in the cover. (Fig. 1.2DD)

12. Line up the cover assembly with the shaft journals and dowel pins (Fig. 1.2EE). Lightly tap the back of the cover until dowel pins are completely engaged. Check the seal making sure it is seated properly with no foreign material pinched between the surfaces.

13. Place the screws in the cover holes and turn until the threads engage. Use care so that cross threading does not occur.

14. Torque the four bolts by criss crossing back and forth a little at a time until you reach the final torque of 47 ft lbs (64 Nm). (Fig. 1.2FF)

15. After the pump has been disassembled and reassembled it is suggested that the pump be run in and tested on an appropriate test stand. This is done to verify the volumetric efficiency and the integrity of the unit.

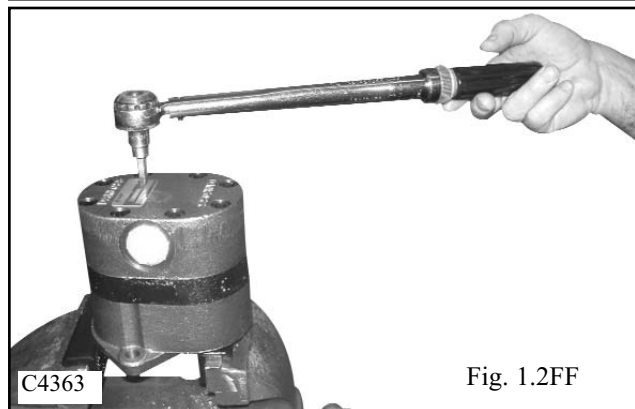
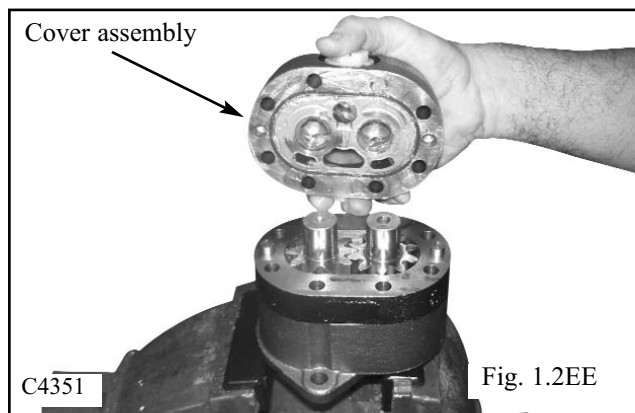
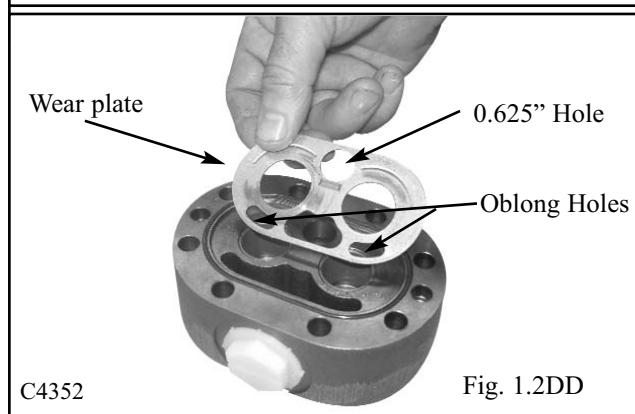
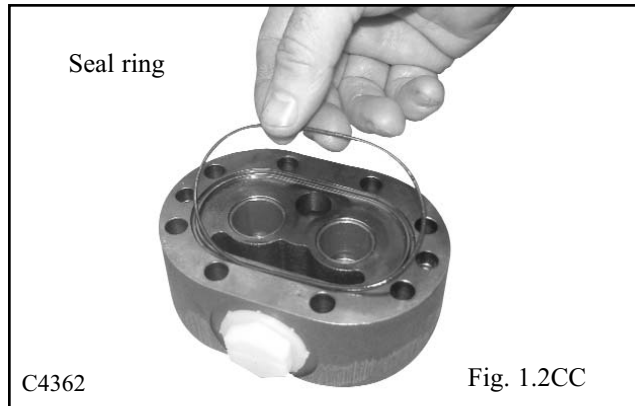

CONTROL VALVE 1.3

1

Testing and Adjusting the Relief Valve Pressure

Hoses and gauges required for this test must be capable of withstanding 5000 psi (345 bar) continuous pressure, and hydraulic flow meter capable of measuring 30 gallons per minute. (113 l/min) (Fig. 1.3A) **This test also checks the status of the gear pump capacities.**

Pressure fluctuations may be caused by restricted oil flow through the relief valve. The relief valve may need to be replaced when its' filter is contaminated.

1 Install the flow meter / pressure tester to the auxiliary hydraulic quick couplers. (Fig. 1.3A) The female coupler attached to the loader provides the power out when the auxiliary control is engaged. (fig. C4804) Connect the flow meter and pressure gauge inlet side to match the power out of the female auxiliary coupler to prevent meter and gauge damage. Be sure to connect a return line to the male auxiliary hydraulic quick coupler. (Fig. 1.3C)

2 Start the engine and engage the auxiliary hydraulic system. Increase the engine speed to full operating rpm. (See Section 7 for checking and adjusting engine speed)

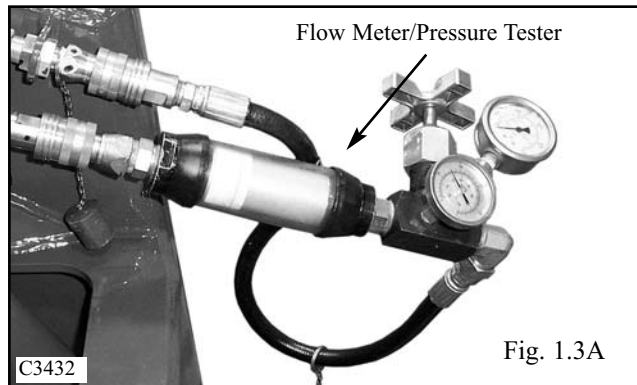

Fig. 1.3A

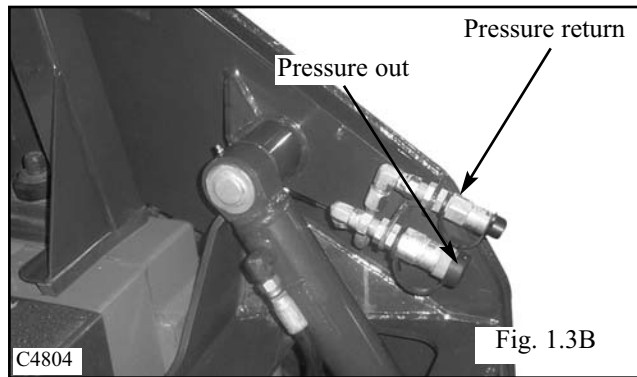

Fig. 1.3B

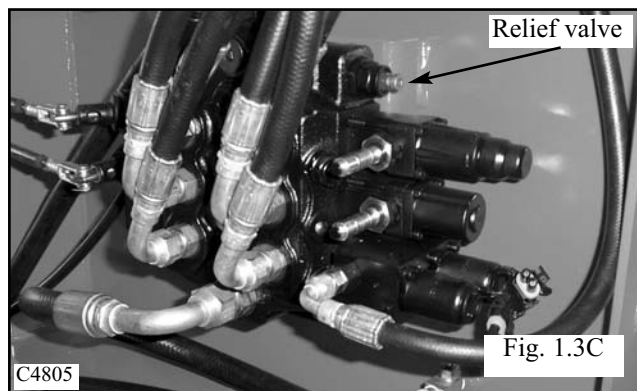

Fig. 1.3C



CAUTION

Adjusting the relief valve setting too high may cause damage to the gear pump.

3 Turn the flow control valve on the flow meter to restrict the oil flow down to 2 gal / min. (7.5 l/min) As you are turning the flow control valve, watch the pressure gauge and make sure it does not go over 5000 psi.(345 bar) Stop further adjustment immediately if the reading goes over this setting. Shut off the auxiliary hydraulic system and shut off the engine. Move to step 6 to make initial setting.



WARNING

To prevent personal injury or damage to the loader, do not adjust the relief valve while the engine is operating.

CONTROL VALVE 1.3

1

4 Repeat steps 2 and 3 if necessary. Allow the loader to operate at this setting until the oil temperature has increased to 160° F (71°C), operating temperature.

5 Turn the flow control valve further to restrict the oil flow to no flow (Zero). Correct pressure setting is 3000 psi +/- 100 psi. (207 bar, +/-6.9 bar)

6 If adjustment is necessary, shut down the auxiliary hydraulic system, shut off the engine and return the flow control valve to the open position. Locate the control valve in the engine compartment.

7 Loosen the jam nut on the relief valve adjusting screw and turn the screw clockwise, counting the turns, until the screw bottoms out. (Fig. 1.3D)

8 Turn the screw back. Reduce the number of turns that you turned in to increase the pressure, increase the number of turns to decrease the pressure.

9 Retake the pressure readings by performing steps 2 through 5. If necessary make further adjustments by repeating steps 6 through 9.

NOTE: If adequate pressure and / or flow is not available, the gear pump could be failing, the intake to the gear pump is restricted, or the filter in the relief valve is clogged.

Control Valve Replacement

1 Remove any attachment and shut off the engine. Turn the key on with the safety devices activated so the pedals can be moved. Slowly jog both pedals and press the electric auxiliary switch. This will take any back pressure out of the system. Access the engine compartment.

IMPORTANT

Clean the work area prior to repair. Cap all open lines, fittings and ports to prevent contamination.

2 Disconnect the control rods, electrical solenoid spool locks, and electrical auxiliary solenoid wiring connectors if equipped. (Fig. 1.3E, 1.3F)

3 Disconnect the inlet hose coming from the gear pump. Cap the hose and fitting and remove the hydraulic fitting in the control valve.

4 Disconnect the 6 hoses going to the boom, bucket, and auxiliary circuits. Marking the hoses as you remove them is recommended to ease re-assembly and ensure the circuits are functioning properly at restart. (Fig. 1.3G)

5 Disconnect the accumulator line from the electric auxiliary circuit and remove the adapter fittings. Plug and cap all open ports and hose ends.

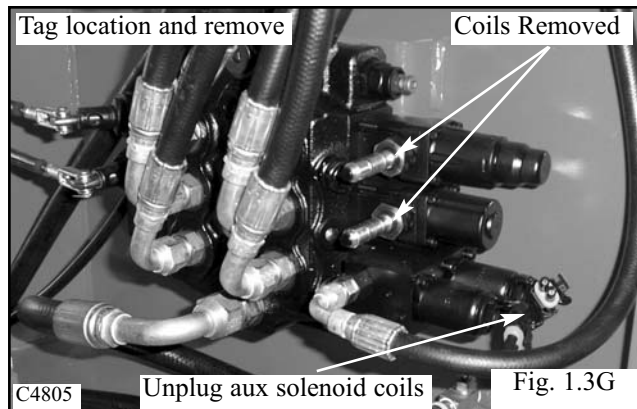
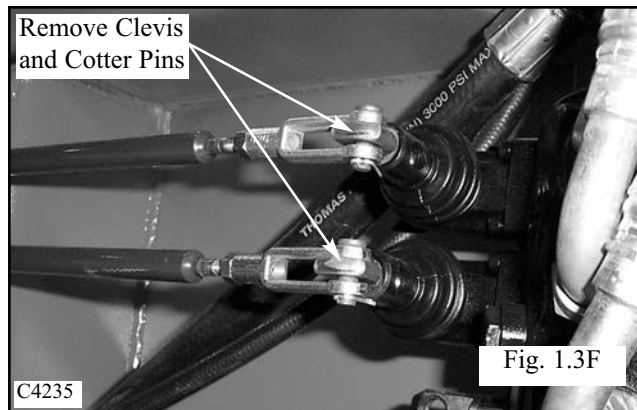
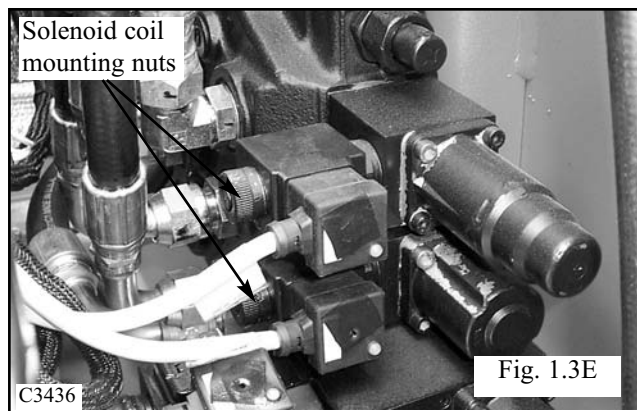
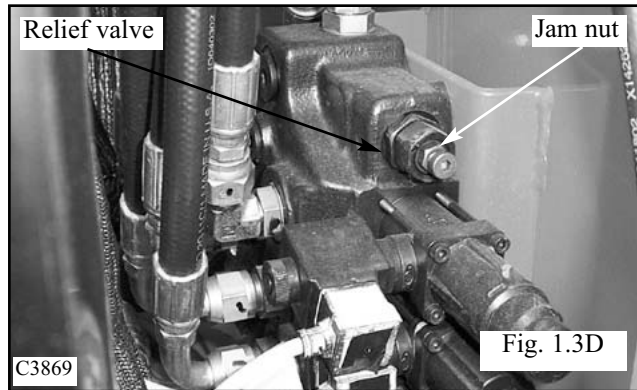

CONTROL VALVE 1.3

1

6 Disconnect the return line from the control valve and remove the adapter fitting. Plug and cap all open ports and hose ends. (Fig. 1.3H)

7 Remove the 3 bolts holding the control valve to the mount and remove the control valve. (Fig. 1.3I)

8 Remove any fittings left in the control valve. Cap all open ports to prevent contamination. Place these fittings in the new or repaired control valve. Be sure to check all fitting flares and o-rings for damage and replace as required.

IMPORTANT

Follow the hydraulic fitting torque chart in Section 1.10 when connecting fittings and lines.

9 Assemble the control valve to the loader in the reverse order above. Torque the bolts holding the control valve to the mount at 15 ft lbs. (20.4 Nm)

10 After all connections have been made, including the control valve electrical connections, check the oil level in the hydraulic reservoir and top off if necessary. (Fig. 1.3J, 1.3K)



WARNING

Use extreme caution when checking the hydraulic system for leaks. Fluid under pressure can penetrate the skin and cause serious injury.

11 Start the engine and cycle the various hydraulic functions to check for leaks. Make sure the control valve lock system is functioning properly. Do not use your hands to check for leak locations, fluid under operating pressure can penetrate the skin and cause serious personal injury.

12 After checking for leaks, you must retest the relief valve setting as outlined on page 1-15 Testing and adjusting.



WARNING

All safety switches must be connected and functioning to prevent possible operator injury.

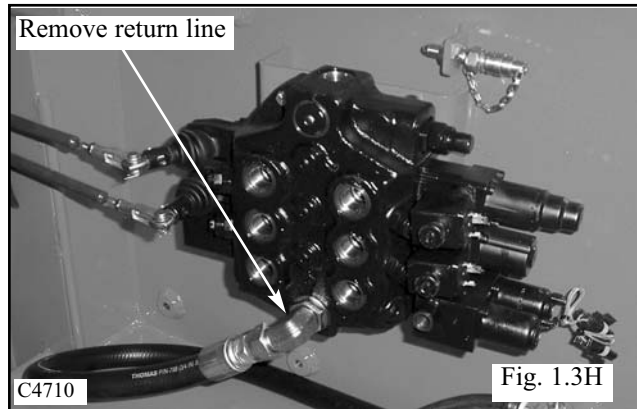

Fig. 1.3H

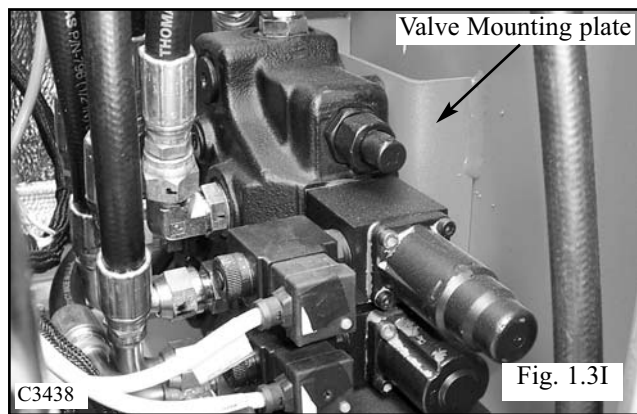

Fig. 1.3I

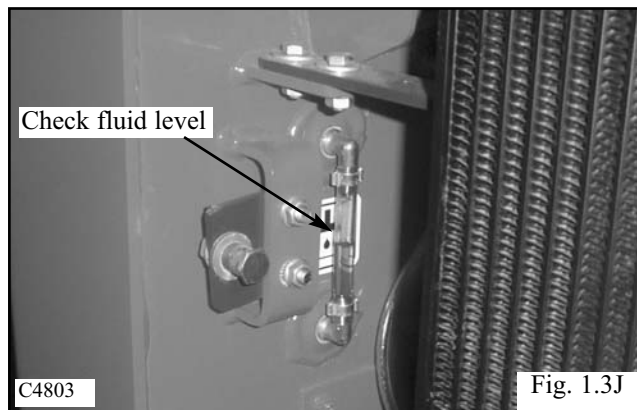

Fig. 1.3J

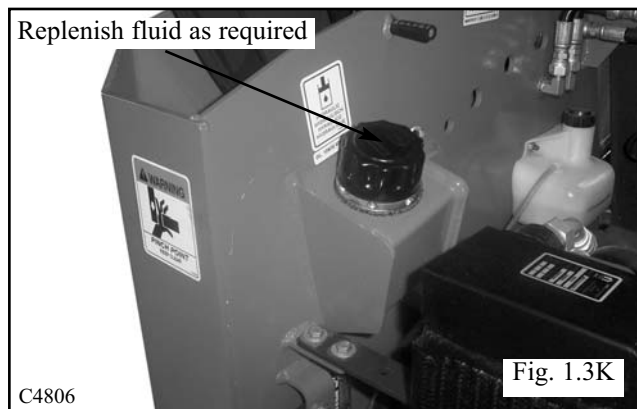
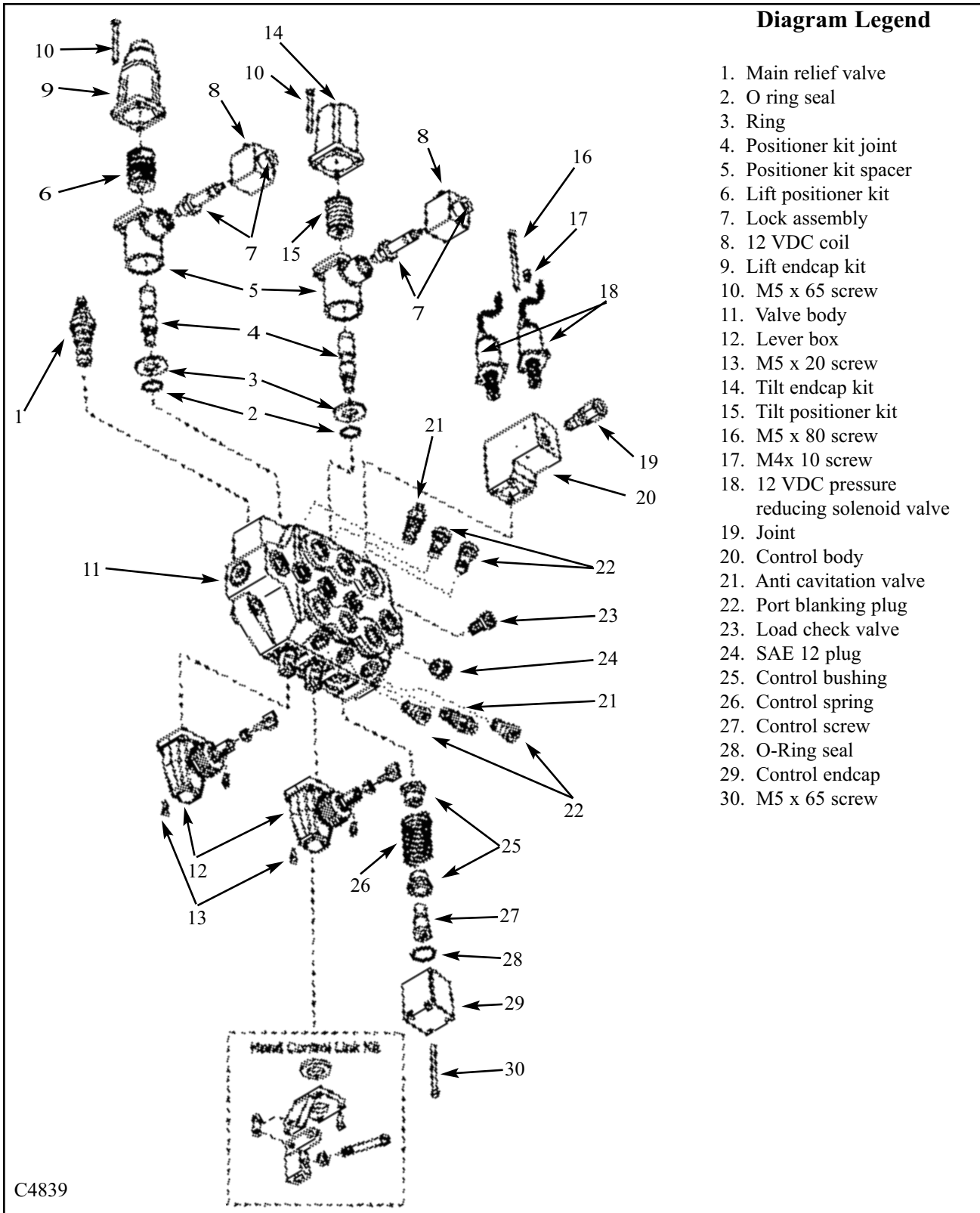

Fig. 1.3K

CONTROL VALVE 1.3

1

Control Valve Disassembly 205



CONTROL VALVE 1.3

1

Disassembly / Repair

Before disassembling the hydraulic control valve, clean the body with a suitable solvent and dry with compressed air. (Fig. 1.3L)

Ensure all openings are plugged to prevent solvents and dirt from contaminating the control valve assembly.

 **WARNING**
To avoid eye injury, use safety goggles when cleaning with compressed air.

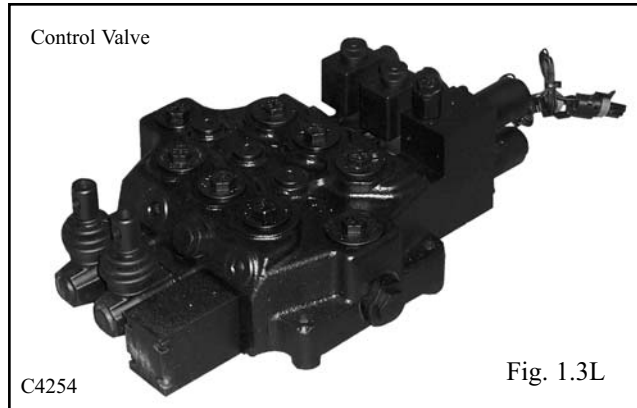

1. Remove the pressure relief valve. Discard the O-rings. (Fig. 1.3M)

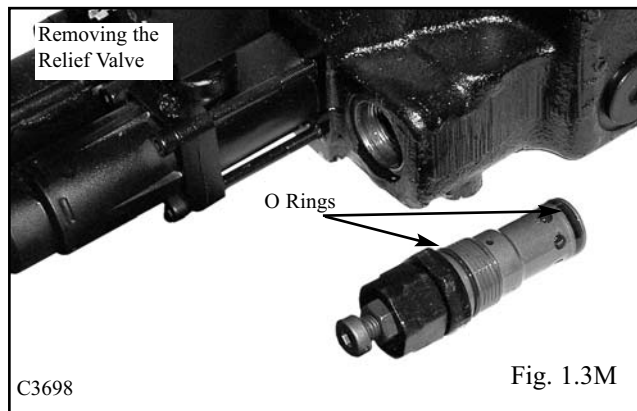

2. Remove the solenoid coils and locking pin from the valve lock block. (Fig. 1.3N, 1.3O) There are 2 O-ring seals located on either side of the solenoid coils.

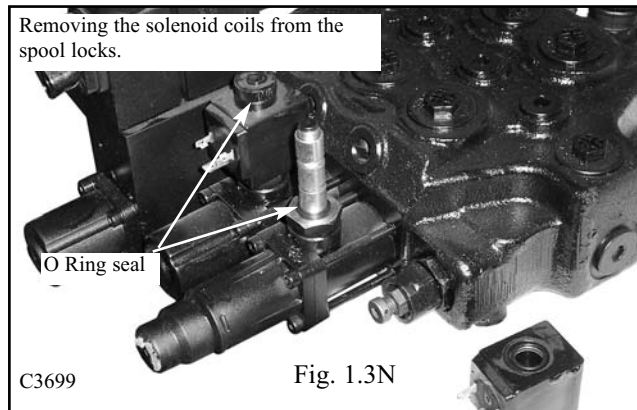

3. Remove the spring return detent kit and spring center cap locks. (Fig. 1.3P, 1.3Q)

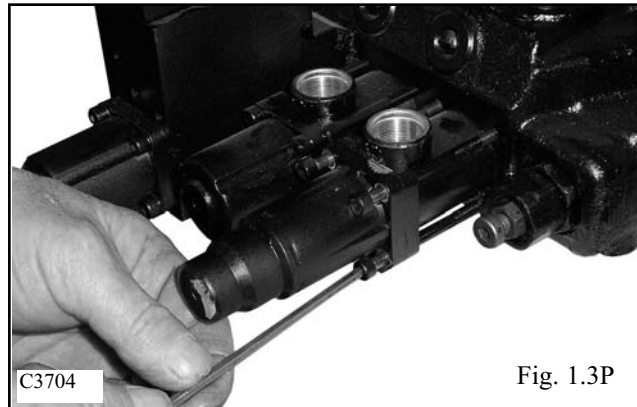
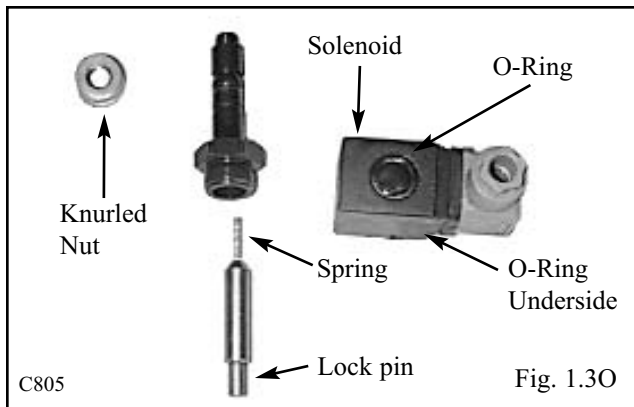

CONTROL VALVE 1.3

1

Disassembly / Repair (cont'd)

4 Remove the control box from the spool linkage end. (Fig. 1.3R) The box needs to be tilted upward towards the valve to release the hardened ball from the hole in the spool end, and then pull away from the valve.

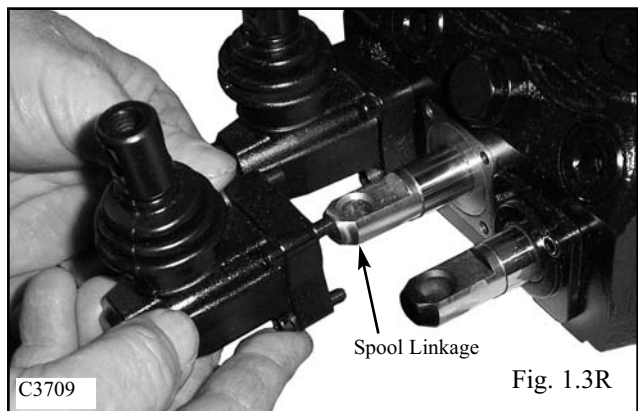
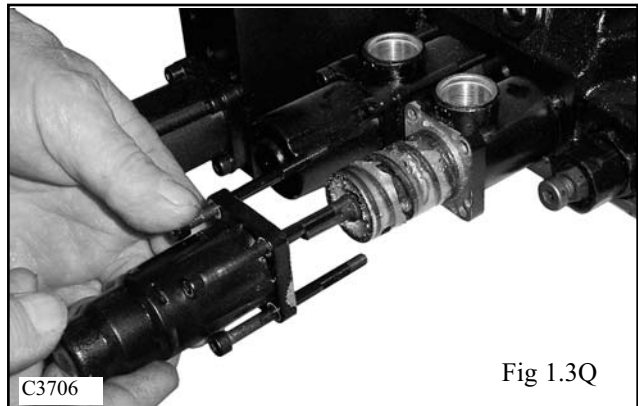

5 Pull out the spool. (Fig. 1.3S) As you pull out the spool, note it's smooth action as it comes out of the valve body. The spool should move freely and smoothly in the bore of the valve body. Check the control valve spool and bore for scuff marks or abnormal wear. Replace the spool and or control valve if signs of wear are present.

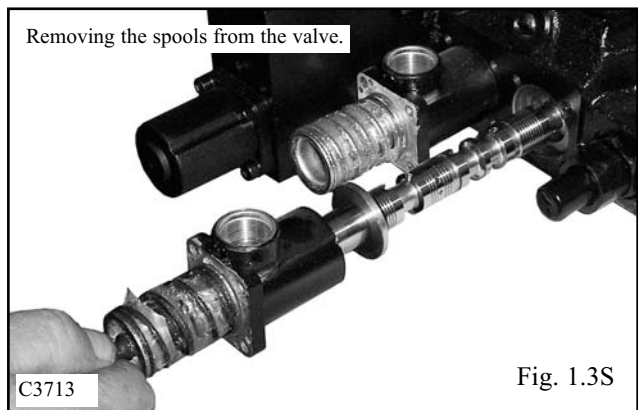

6 Remove the check valves from control valve body. (Fig. 1.3T) They are located between the ports of each section. Check the seat and poppet of the valve body and check valve.

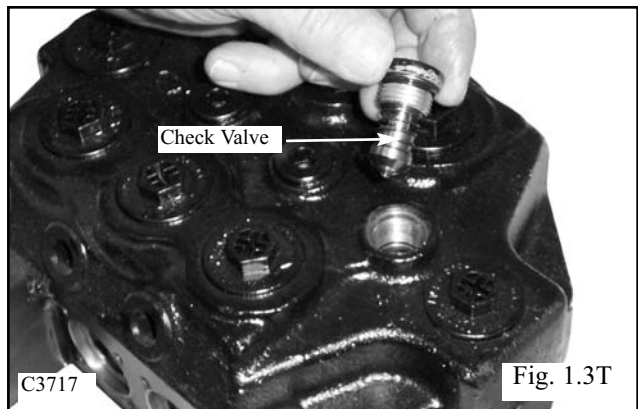

CONTROL VALVE 1.3

1

Disassembly Repair (cont'd)

7 When replacing the spool to the control valve, use new O-ring seals and apply system oil to the O-rings and spools. (Fig. 1.3U).

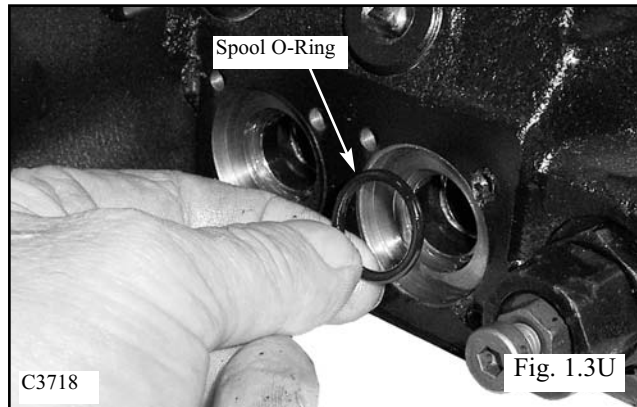

8 Fit the seal washer to the control valve with the beveled side of the washer facing the control valve. (Fig. 1.3V) Fit the spool to the control valve now if repairs are not needed to the detent or spring return mechanism. Use system oil to lubricate the spool before inserting to the control valve.

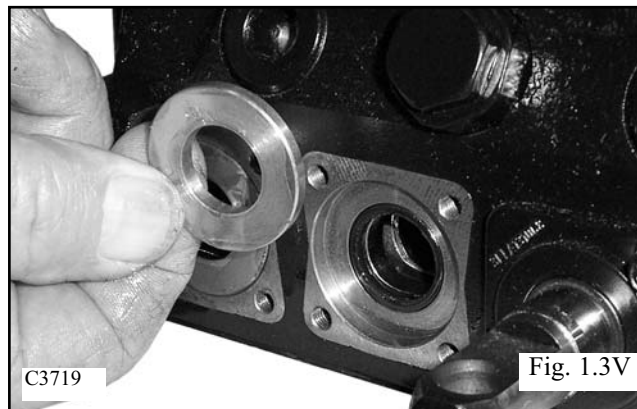

9 Place the cable end of the spool in a vice, or insert a screw driver through the clevis pin holes, to keep it from turning. The detent is threaded to the spool and can be removed for inspection or repairs.(Fig. 1.3W)

Replace broken springs, worn detents and / or damaged detent balls with a new detent kit.

Apply Loctite 542 to the threads of the detent when installing to the spool.

Apply Castrol "Sphero!" TN grease to the inside of the spring cover.



10 When installing the detent to the control valve spool, apply Loctite type (542) to the threads. Tighten the detent to the spool at 17 ft lbs (24 Nm). (Fig. 1.3X)



CONTROL VALVE 1.3

1

Disassembly / Repair (cont'd)

11 Install the spring return / centering cover and tighten the mounting screws evenly to 5 ft lbs (6 Nm). Install the end cap to the cover and tighten to 7 ft lbs (9.8 Nm). (Fig. 1.3Y)

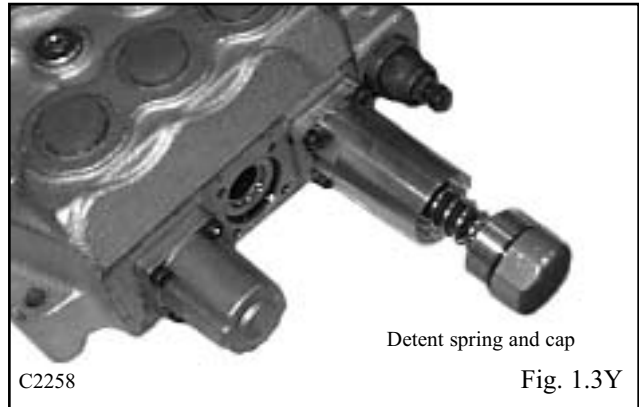

Solenoid Controlled Auxiliary

1 Remove the screws retaining the solenoid coil. Remove the 12 VDC solenoid coils. (Fig. 1.3Z)

2 Inspected the O ring on the solenoid coils for damage. Replace if necessary.

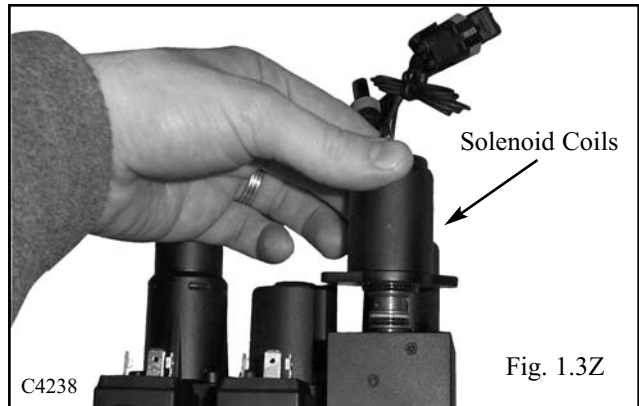

3 Remove the screws retaining the solenoid assembly to the control valve. (Fig. 1.3AA). Upon assembly tighten the screws to 5 ft lbs (7 Nm).

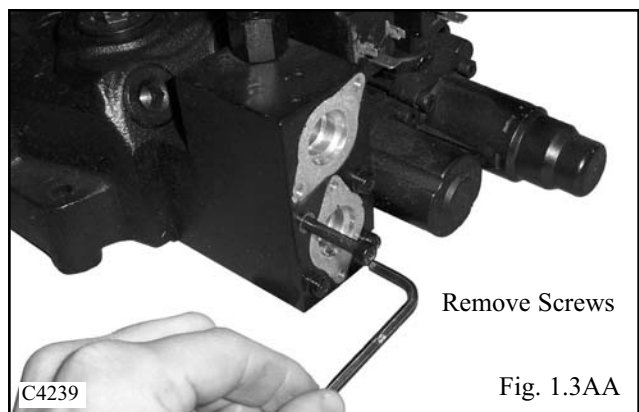

CONTROL VALVE 1.3

1

Disassembly / Repair (cont'd)

4 Remove the solenoid assembly from the control valve. (Fig. 1.3BB)

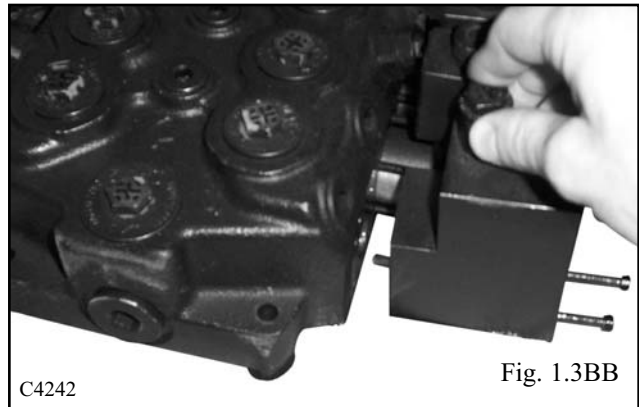

5 Remove the screws and the bottom end cap from auxiliary section.(Fig.1.3CC) Upon assembly torque the screws to 5 ft lbs (7 Nm)

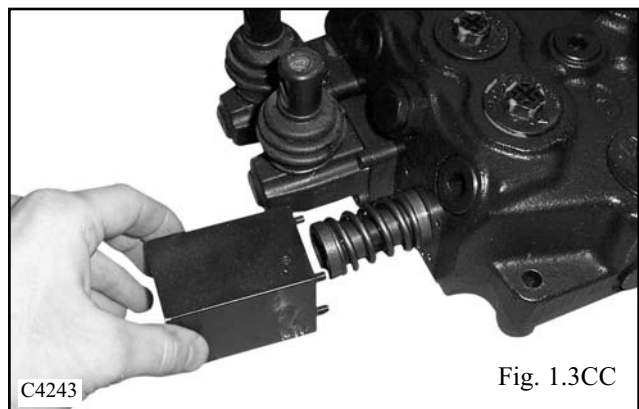

6 Remove the solenoid spool assembly from the control valve. (Fig. 1.3CC) Note the effort required to remove the spool from the spool bore. It should come out smoothly without binding or “snagging” throughout it’s travel.

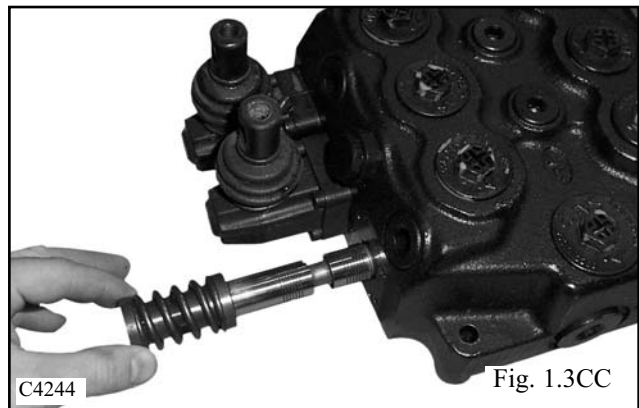

7 Inspect the spool and spool bore for abnormal wear. (Fig. 1.3DD) Replace the spool and / or the control valve if large scratches or indentations are present in the spool or spool bore. Minor scratches can be removed from the spool with extra fine emery cloth.

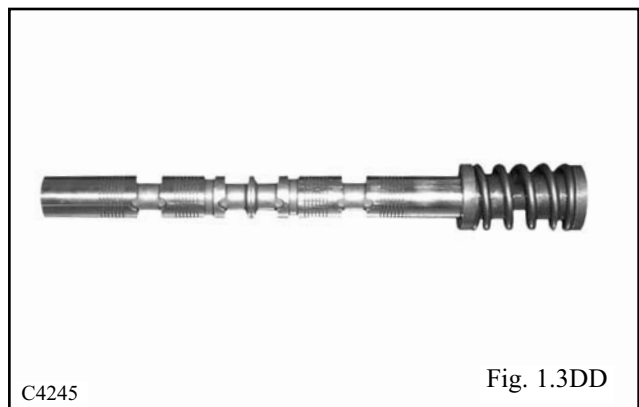

CONTROL VALVE 1.3

1

Disassembly / Repair (cont'd)

8 Hold the spool with a Hex allen wrench while removing retaining screw. (Fig. 1.3FF) Remove the spring and spring bushings from the spool assembly. (Fig. 1.3GG) When installing the spring assembly to the spool, apply Loctite 542 to the threads and tighten the screw to 18 ft lbs (24 Nm).

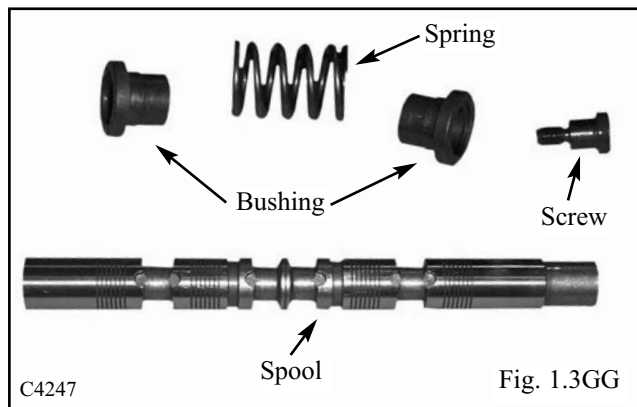
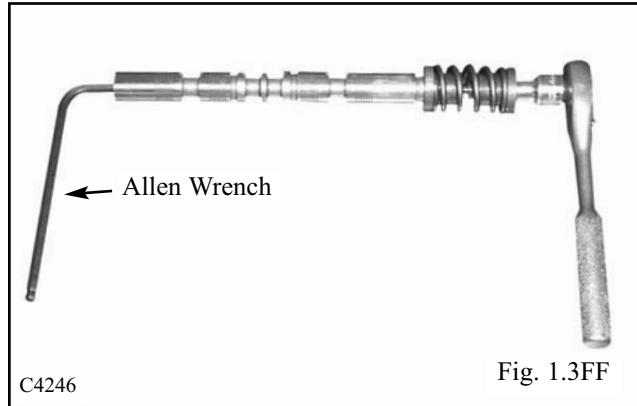

9 Upon assembly, use new O-ring seals. (Fig. 1.3HH) Don't overlook the small O-ring seal between the cylinder and valve body. (Fig. 1.3II) Lubricate the spool O-ring seals with system oil. Apply Castrol "Sphero" grease to the inside of the spring covers.

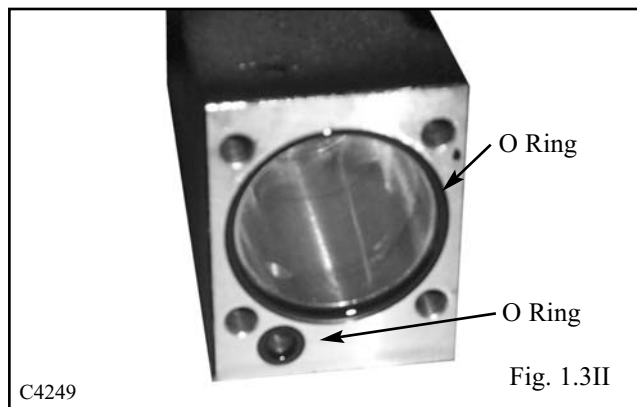
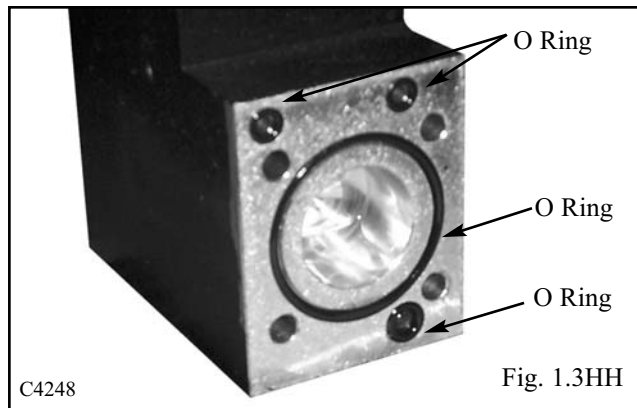

HYDRAULIC CYLINDERS 1.4

1

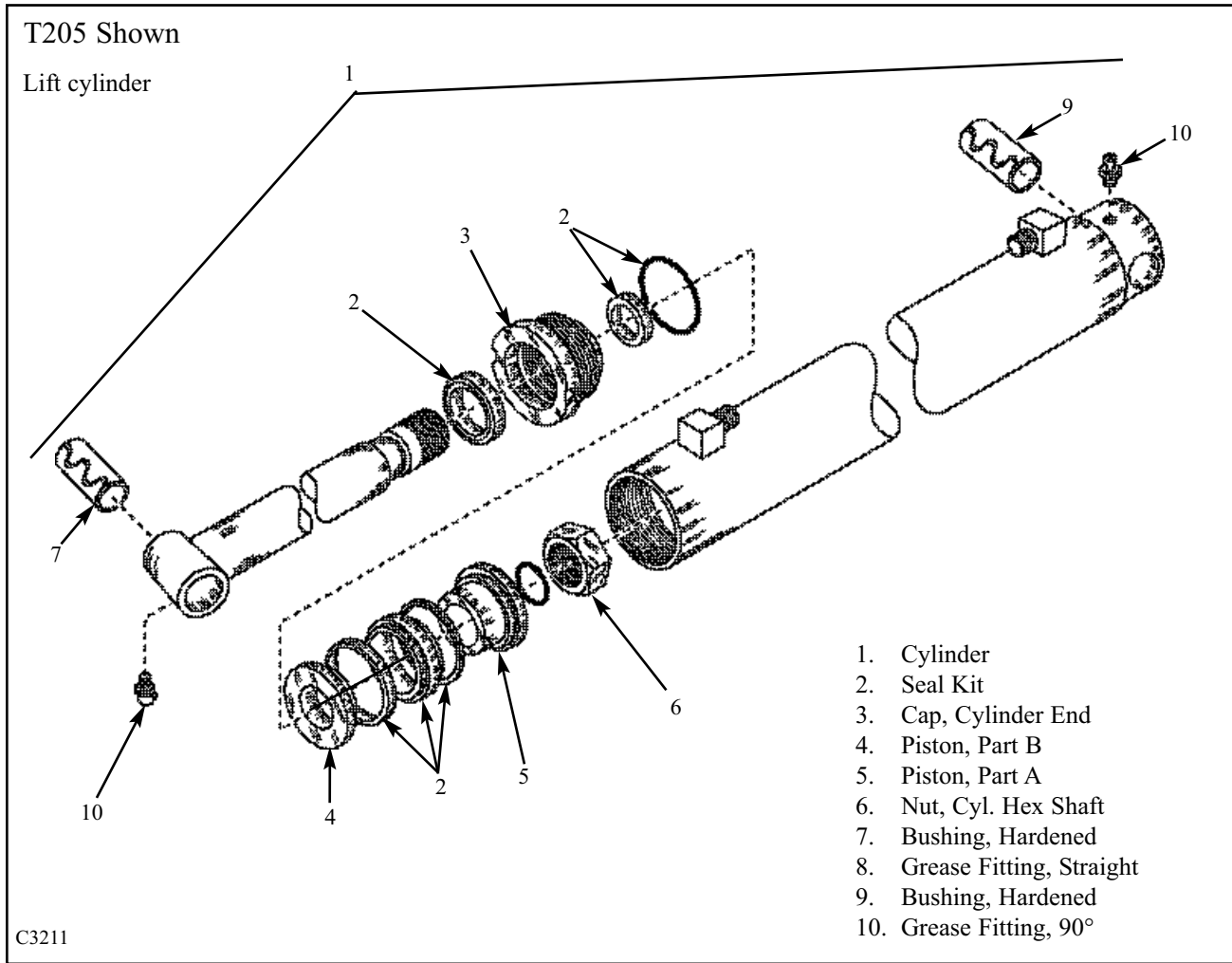

General Information

All cylinders are a double acting, designed to extend and retract under pressure.

The piston rods, which are made of high strength distortion free material, are precision ground and hard chrome plated. The cylinder barrels are micro honed to close tolerance, straightness and smooth finish for long piston packing seal life.

All cylinders have a 2 piece piston assembly made of ductile iron and a polypac seal arrangement consisting of a piston seal and 2 wear rings.

The rod seal is a "U" cup design, with the "U" facing the pressurized oil. The rod wiper keeps foreign matter from entering the cylinder by wiping the rod clean as the cylinder retracts.

The gland nut seal is of an "O" - ring design. This seal keeps the oil from leaking around the gland nut and cylinder barrel threads.

Certain cylinders have spacers in them. These spacers are used to limit the stroke of the rod.

Some cylinders also have replaceable hardened bushings in the pivot areas that can be serviced when worn out.

HYDRAULIC CYLINDERS 1.4

1

Lift Cylinder Removal



WARNING

To prevent personal injury never repair or tighten hydraulic hoses while the engine is operating or the system is under pressure.

The following procedure will assist you in cylinder removal.

For removal of the boom cylinders:

IMPORTANT

Cap all open lines and ports to prevent contamination.

- 1 Lower the boom arms, stop the engine and cycle the controls to relieve any hydraulic back pressure in the system. Lock the control in the float or detent position.
- 2 Remove the hydraulic tubing from the cylinder. (Fig. 1.4A) Cap all open ports and lines to prevent contamination.
- 3 Remove the lock nut and bolt from both mounting pins. (Fig. 1.4B)
- 4 Remove the tubing clamp located on the cylinder barrel. Replace clamp as required.
- 5 Remove the front pivot pin by pushing the pin out from behind the boom arm, out toward you. (Fig. 1.4C) With an appropriate punch and hammer to prevent brooming of the pin, remove the rear pin. (Fig. 1.4D) Brooming the pin makes it difficult to remove.
- 6 Remove the cylinder from the loader.
- 7 Upon replacement, inspect the pivot pins and cylinder bushings for any wear. Replace if necessary. Reverse order above for installation.
- 8 Upon start up, check for system leaks and replenish the hydraulic reservoir as required.



WARNING

Use extreme caution when checking the hydraulic system for leaks. Fluid under pressure can penetrate the skin and cause serious injury.

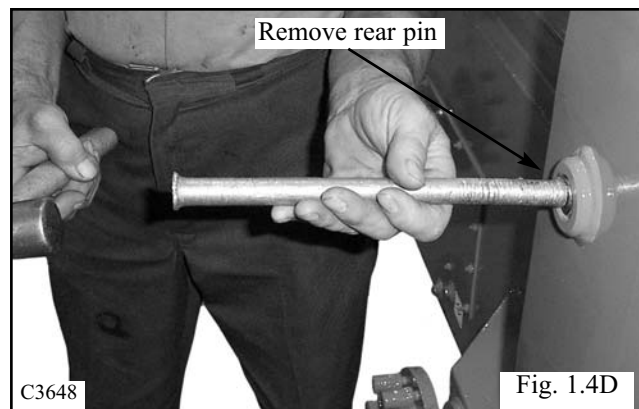
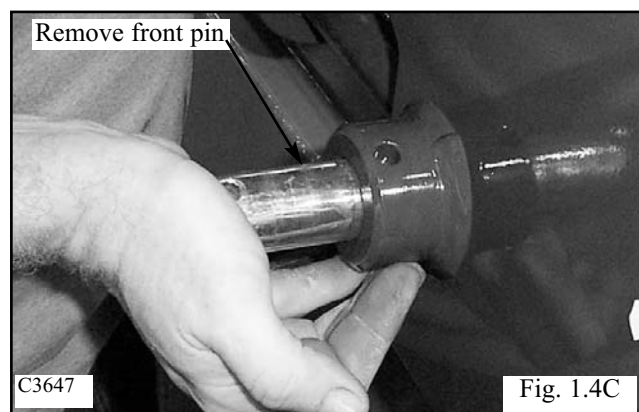
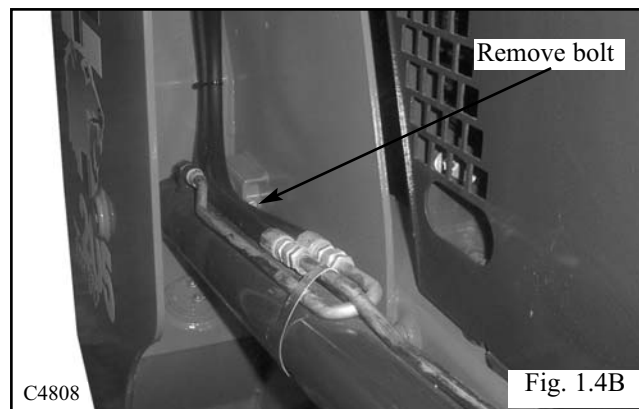
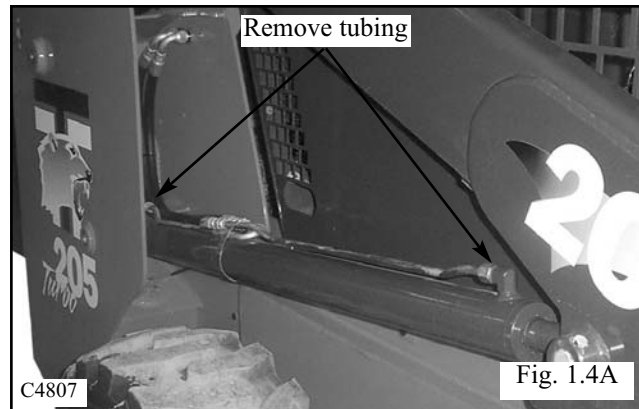

HYDRAULIC CYLINDERS 1.4

1

Tilt cylinder Removal

For tilt cylinder removal:

- 1 Lower the boom arms, remove any attachment and extend the tilt cylinders. Shut off the engine and cycle the controls to relieve excessive back pressure in the hydraulic system.(Fig. 1.4E)
- 2 Loosen or remove the hydraulic clamps on the hoses under the boom arm step. Loosen the hoses under the boom arm step (Fig. 1.4F). Use a container to catch any waste oil to prevent environmental contamination.
- 3 Remove the hydraulic hoses from the tilt cylinder. Plug and or cap all open ports or lines to prevent contamination. (Fig. 1.4G)
- 4 Remove the lock nuts from the bolts retaining the pivot pins to the loader and remove the bolts.
- 5 Remove the pivot pins by tapping out with a brass drift pin. (Fig. 1.4H)
- 6 Remove the cylinder from the loader.
- 7 Upon reassembly, inspect the pivot pins and bushings for wear and replace as required. Reverse order for cylinder installation.
- 8 Upon start up, check for system leaks and replenish the hydraulic oil reservoir as required.

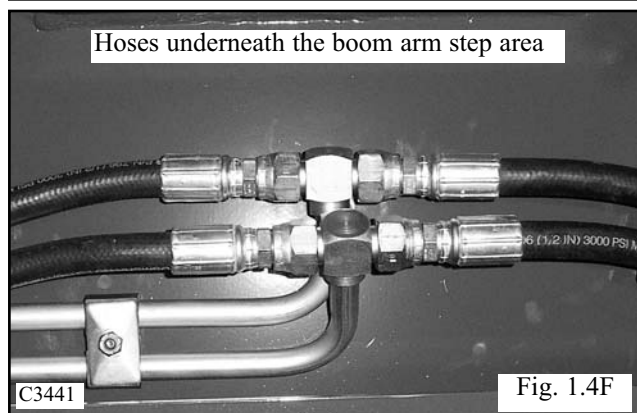
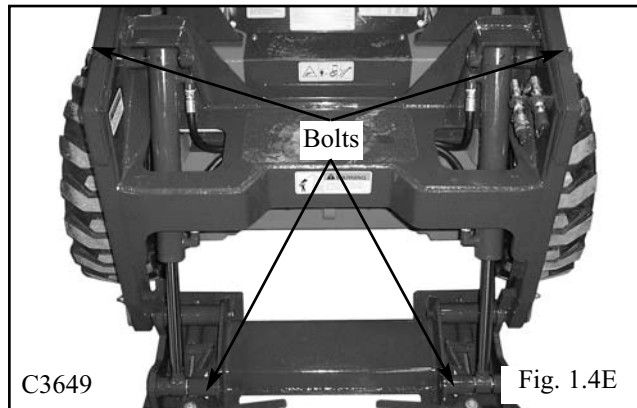

 **WARNING**

Use extreme caution when checking the hydraulic system for leaks. Fluid under pressure can penetrate the skin and cause serious injury. Never tighten or repair hydraulic lines while the engine is operating.

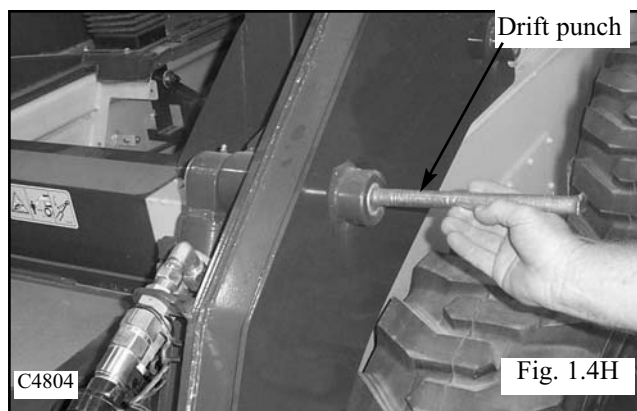
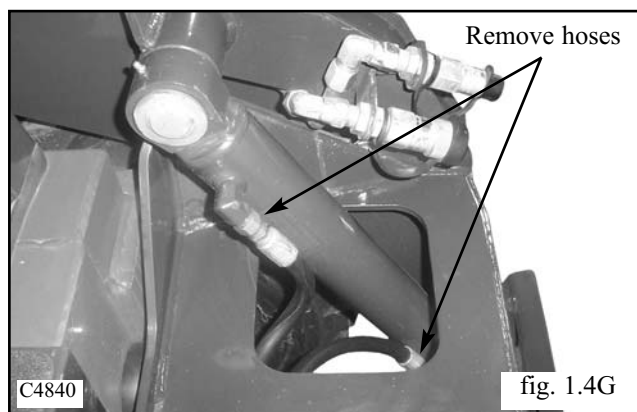

HYDRAULIC CYLINDERS 1.4

1

Testing the Piston Seals

Before performing this test, ensure the control linkages are not binding and the hydraulic control valve spools are centering in the neutral position. Check the hydraulic circuit for external leaks. These conditions will give the same symptoms as a worn piston seal. If the cylinders under pressure are sluggish or stop functioning, these would indicate that oil is leaking by the cylinder piston seal. The following test can be performed to check the cylinder piston seal.

IMPORTANT

Allowable boom or bucket cylinder drop: 1.5" in 3 minutes, @ loaded rating and operating temperature.



WARNING

Use extreme caution when checking the hydraulic system for leaks. Fluid under pressure can penetrate the skin and cause serious injury.

1. Retract the cylinder(s) to be tested. Shut off the engine and cycle the controls to release the hydraulic pressure. Have a container ready to catch any waste oil to prevent environmental contamination.
2. Disconnect the hoses from the cylinder to be tested. Cap the hoses with plugs to prevent contamination.
3. Disconnect the cylinder to be tested as outlined on page 1-26 or 1-27.
4. Place the base or fixed end of the cylinder in a vice or a support to hold the cylinder.
5. Extend the cylinder ram about 6 ~ 8". Fill the fixed end cylinder port with hydraulic oil using a funnel.
6. Cap both ports with a 3/4 JIC steel cap to prevent system pressure from escaping.
7. Apply pressure using your hand to the ram.
(Fig. 1.4L)
8. Monitor the movement of the ram. If the ram slowly retracts back to its' original position, then the seals are bad and need replacement. If the cylinder stays extended then you may need to check the load check valves or spool wear in the hydraulic control valve.
9. Repeat for all remaining cylinders.

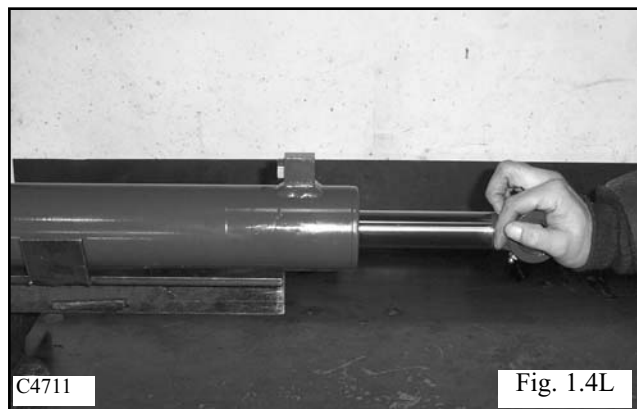
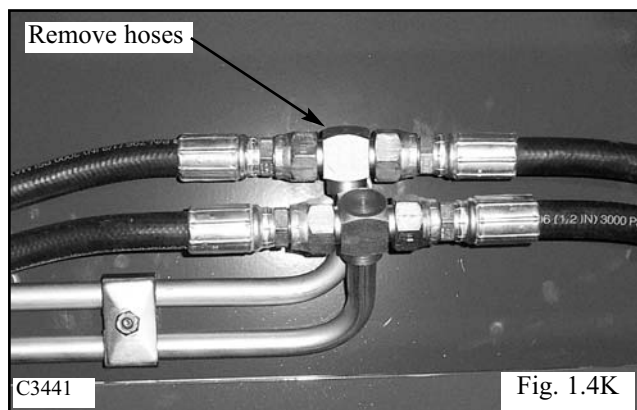
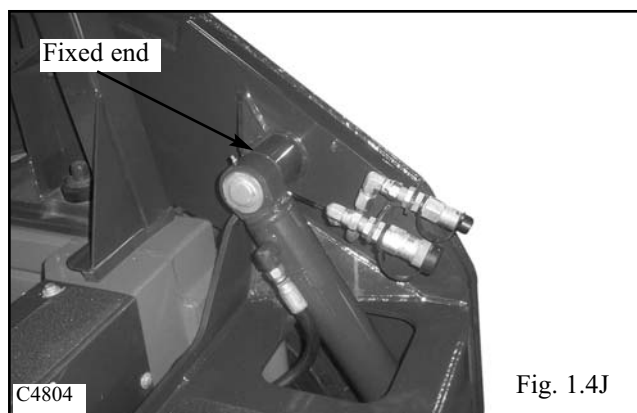
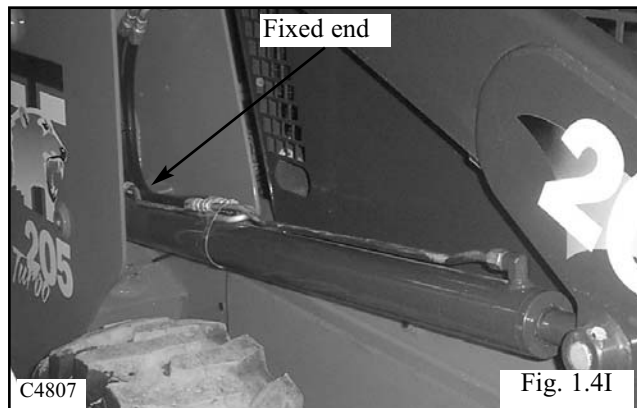

HYDRAULIC CYLINDERS 1.4

1

Cylinder Disassembly

Before Attempting repairs to the hydraulic cylinder, clean the body with a suitable solvent. Ensure all openings are plugged to prevent solvent from entering the cylinder.

- 1 Remove the cylinder as outlined previously.
- 2 Place the base end of the cylinder in a vise or on a pin held in the vise and support the front end of the body. Remove the plugs from the hose ports. (Fig. 1.4M)
- 3 Loosen the gland nut from the cylinder barrel using a spanner wrench. The gland nut threads are coated with loctite bonding agent at time of assembly. It may be necessary to apply heat to the gland nut and cylinder barrel threaded area, with a torch, to ease removal. (Fig. 1.4M)
- 4 Remove the gland nut, rod and piston seal assembly from the barrel. (Fig. 1.4N)

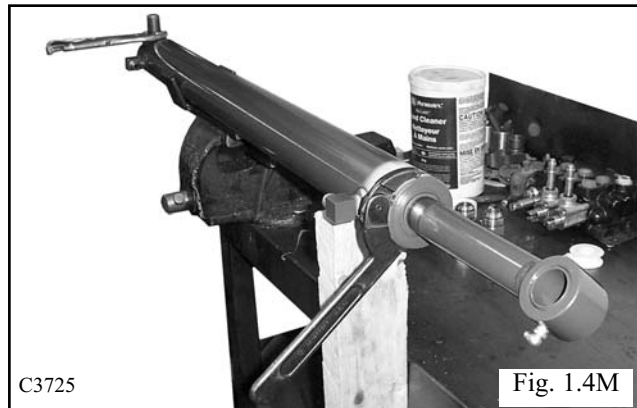

- 5 Place the cylinder rod bushing end in a vise or on a pin held in a vice and remove the lock nut from the rod. (Fig. 1.4O)

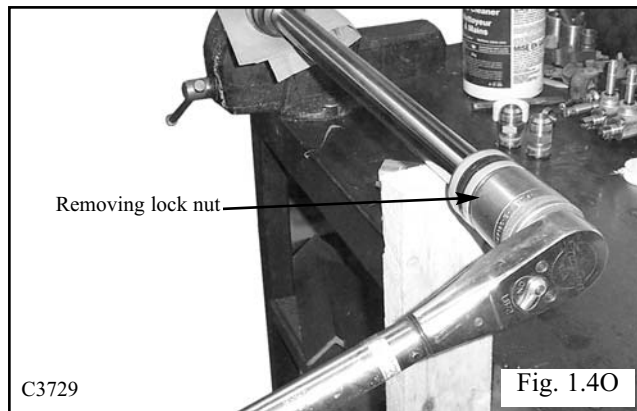

- 6 Remove the 2 piece piston assembly from the rod. (Fig. 1.4P)
- 7 NOTE: Some piston assemblies rear piston parts are threaded onto the rod. You will need to use a spanner wrench to remove this type of rear piston.



HYDRAULIC CYLINDERS 1.4

1

8 Depending on the design of the rear piston, non threaded type, remove and discard the o-ring seal from the end of the cylinder rod. (Fig. 1.4Q)

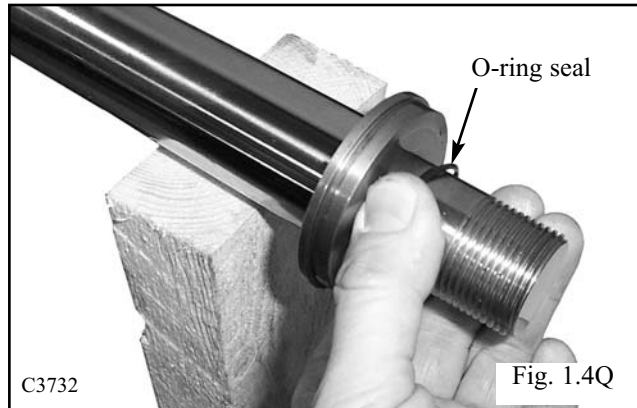

9 Remove the gland nut assembly from the cylinder rod. (Fig. 1.4R)

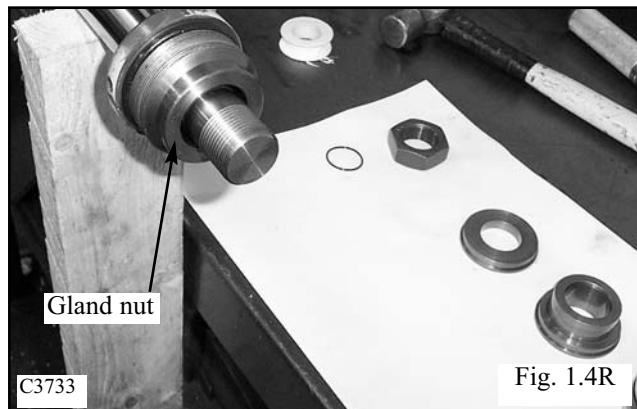

10 Remove and discard the wiper seal, rod seal and o-ring seals and teflon back up washer, (if used), from the gland nut assembly. (Fig. 1.4S) NOTE: Some seal designs may vary from illustration

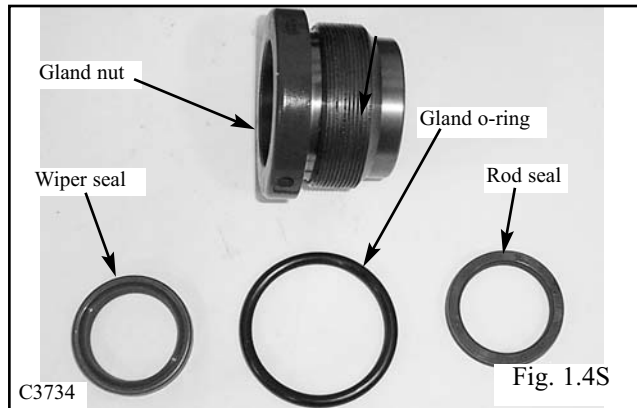

11 Remove and discard the wear rings and piston seal from the piston assembly. (Fig. 1.4T)

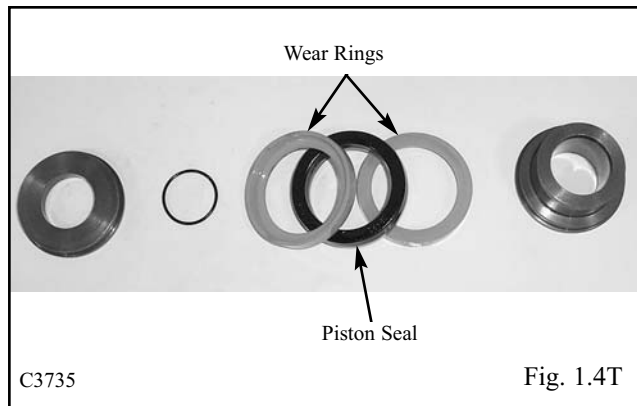

HYDRAULIC CYLINDERS 1.4

1

Cylinder Inspection

1 Inspect the cylinder rod for scratches, dents and other damage. Minor rod damage may be repaired using a fine abrasive. Major scratches or dents are not repairable and the rod must be replaced. The chrome surface must be intact to provide a rust resistant surface. Blemishes on the rod will damage the rod seal and wiper and will cause leaking after a short period of use.

2 Inspect the cylinder rod threads. The threads must be in good condition to withstand the high torque required to secure the piston assembly to the rod.

3 Inspect the gland nut for nicks, burrs or other damage. Minor damage may be repaired using a fine abrasive.

Smooth down edges that could damage seals and cause leakage.

4 Inspect the gland nut threads for damage.

5 Inspect the piston assembly for damage. Remove minor scratches or damage with a fine abrasive.

6 Using a suitable light, inspect the cylinder barrel bore for scratches, dents, burrs or any other damage. Replace the cylinder barrel if there is any evidence of damage.

7 Inspect the cylinder barrel threads for damage. The threads must be in good condition to withstand the high torque required to secure the gland nut assembly to the cylinder barrel.

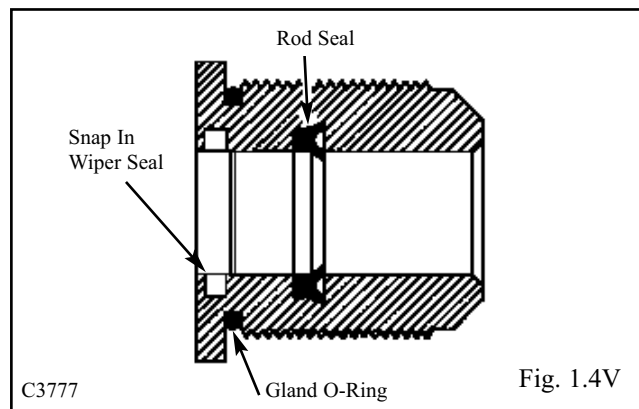
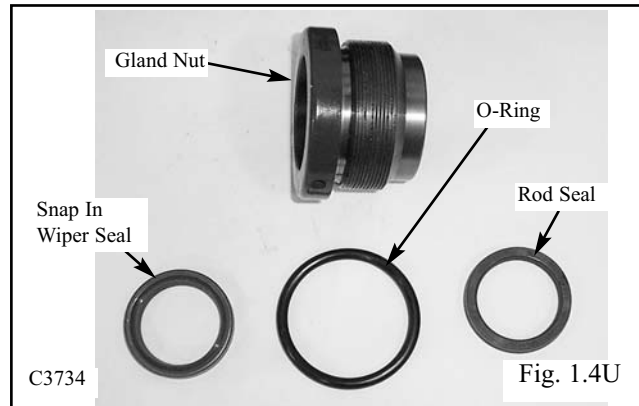

Cylinder Assembly

1 Install a new gland nut rod seal. Form the seal into an oval shape and place it into the gland nut, with the "U" side of the seal facing the barrel end, and slip the seal into the groove. (Fig. 1.4U)

2 Install a new wiper seal in the gland nut. (Fig. 1.4U, 1.4V)

3 Install a new gland nut o-ring seal. (Fig. 1.4U, 1.4V)

4 Apply system oil to the cylinder rod and assemble the gland nut assembly to the rod. (Fig. 1.4W)



HYDRAULIC CYLINDERS 1.4

1

5 Install a new o-ring seal on the cylinder rod (if used). Some cylinder rods are fully threaded to accommodate a threaded type rear piston part. (Fig. 1.4X)

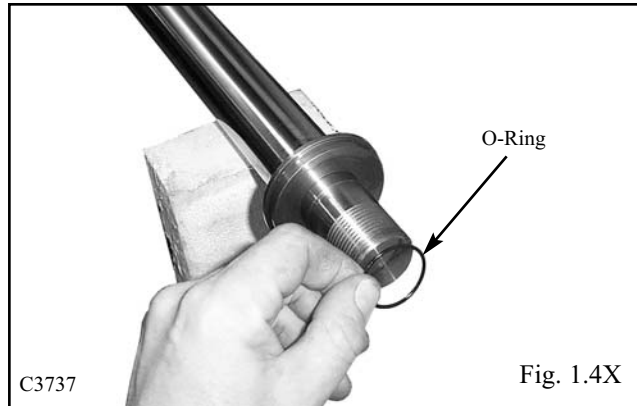

6 Install new wear rings and piston seal to the the 2 piece piston assembly. (Fig. 1.4Y)

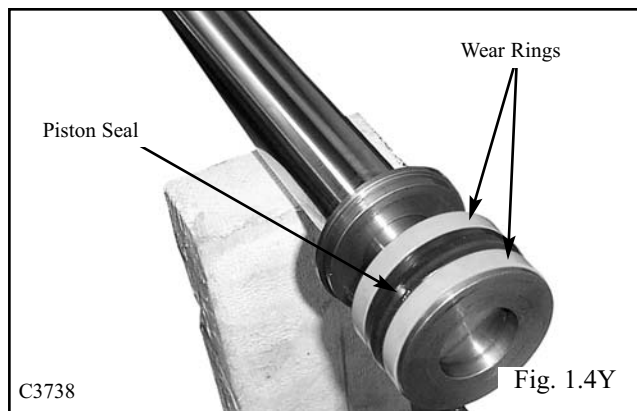

7 Install the piston assembly to the cylinder rod. Some rear piston assemblies are threaded onto the cylinder rod. Use a spanner wrench to install the rear piston part to the cylinder rod. Torque the lock nut to the rod at 250-275 ft lbs (339-373 Nm). (Fig. 1.4Z)

8 Make sure the inside bore of the cylinder barrel is clean. Lubricate the inside of the barrel with system oil. Do not get oil into the threaded area of the barrel.

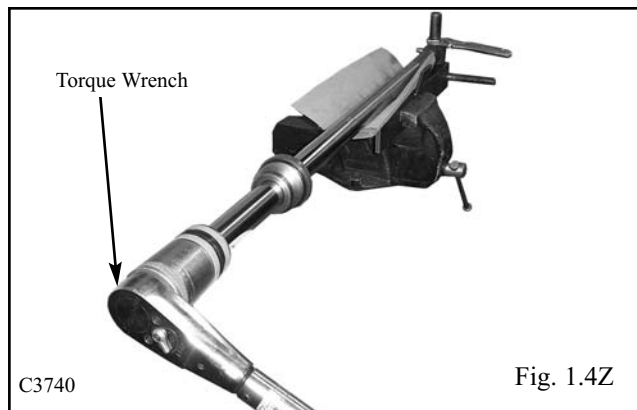

9 Lubricate the piston seal assembly with system oil and install the cylinder rod and piston assembly to the cylinder barrel. (Fig. 1.4AA)

10 Apply loctite 242 to the gland nut threads and tighten the gland nut using a spanner wrench. Tighten the gland nut as much as you can using the spanner wrench. Make sure the threaded area of the gland nut and cylinder barrel are free of oil before applying the loctite bonding adhesive.

11 Assemble the cylinder to the loader.

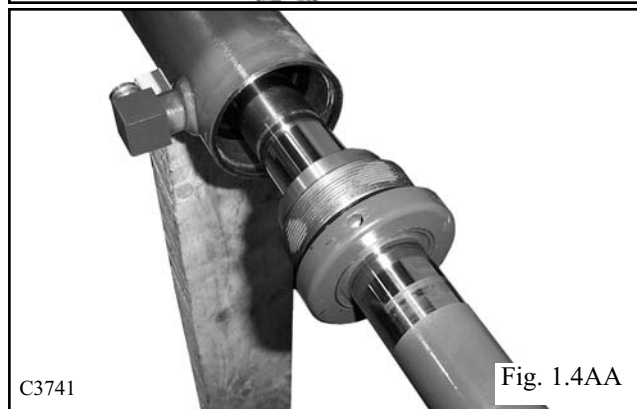

HYDRAULIC OIL FILTER 1.5

1

General Information

The hydraulic oil filter is located in the engine compartment. Access the filter by opening the rear door, then lift the engine compartment cover open. The filter is mounted on the left side, on the hydraulic oil reservoir. All oil returning from the control valve is cooled and then filtered before being used up by the hydraulic system. The hydraulic oil filter is a spin on type with a 5 micron rating. The filter material is a synthetic media which features an accordion pleated design to provide maximum filtration area. Only Thomas approved filters should be used.

The filter mounting head has a built in bypass valve that diverts oil around the filter when more than 25 psi (1.7 bar) differential pressure is required to force oil through the filter.

Filter Replacement

The hydraulic oil filter must be changed after the first 50 hours of operation and every 150 hours thereafter.



WARNING

Never repair or tighten hydraulic lines while the engine is operating or the system is under pressure.

- 1 Lower the boom arms, shut off the engine and engage the parking brake.
 - 2 Open the rear door and raise the engine compartment cover to gain access to the hydraulic filter. (Fig. 1.5A, 1.5B)
 - 3 Clean the area of excess dirt if necessary to prevent contaminating the new filter when installing.
 - 4 Remove the hydraulic oil filter using a proper sized filter wrench. Check to make sure the o-ring seal has come off with the used filter. (Fig. 1.5C)
 - 5 Lubricate the new filter seal with clean system oil.
 - 6 Install the filter and fit hand tight.
 - 7 After start up, check the system for oil leaks.
- Replenish the oil reservoir as required with API 10W30 class SJ. (Fig. 1.5D)

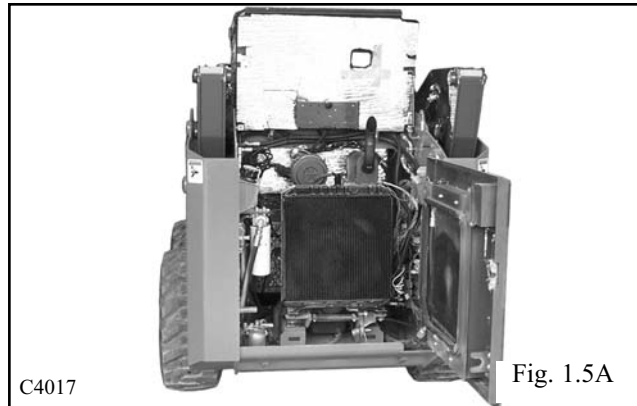

Fig. 1.5A

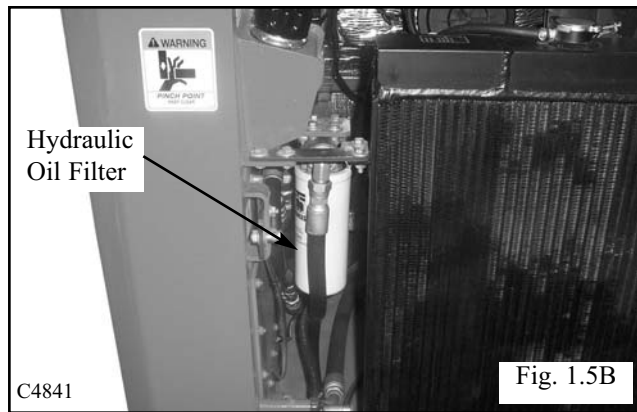

Fig. 1.5B

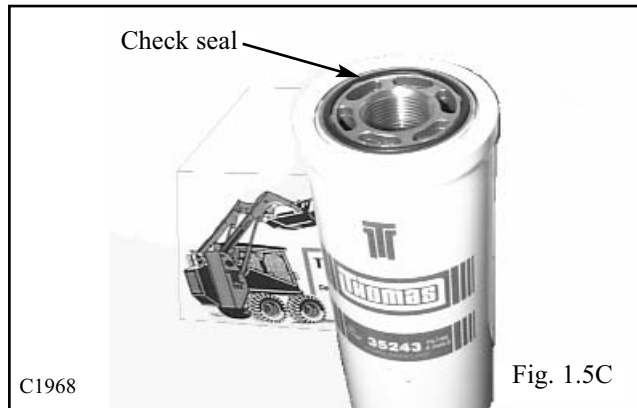

Fig. 1.5C

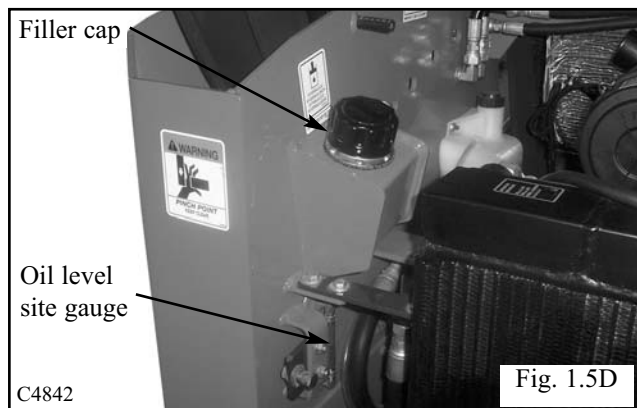

Fig. 1.5D

HYDRAULIC OIL COOLER 1.6

1

General Information

The hydraulic oil cooler is mounted to the rear of the loader (Fig. 1.6A). The RH section of the radiator / oil cooler is designed to cool the engine. The LH section of the radiator / oil cooler is designed to cool the hydraulic oil (Fig. 1.6B). Oil returning from the control valve is circulated through the oil cooler before being sent on to other parts of the hydraulic system. An engine mounted cooling fan drives air through the oil cooler when the rear door is closed. A combination of the cooler size and air flow gives the cooler a rating at 880 BTU / minute (930 kJ / minute).



WARNING

To avoid eye injury, always use safety goggles when cleaning with compressed air.

The oil cooler should be checked daily for dirt build up on the cooling fins. If air flow is restricted through the cooling fins, over heating of the hydraulic system may occur. Clean any dirt build up with compressed air. Flush with water if necessary.

The radiator / oil cooler is surrounded by a shroud. The shroud is bolted to the front of the radiator /oil cooler and the outer edge of the shroud is sealed to the rad/cooler by layer of sealing foam (Fig. 1.6C). This directs the air driven by the engine cooling fan through the radiator / oil cooler. The inside of the rear door utilizes a sealing trim that presses against the rad / cooler when the rear door is closed. The sealing trim should be checked at every service interval to ensure the proper seal. The sealing trim to radiator / oil cooler can be adjusted by loosening the two upper and two lower radiator mounting and moving the radiator back or forward. (Fig. 1.6D).

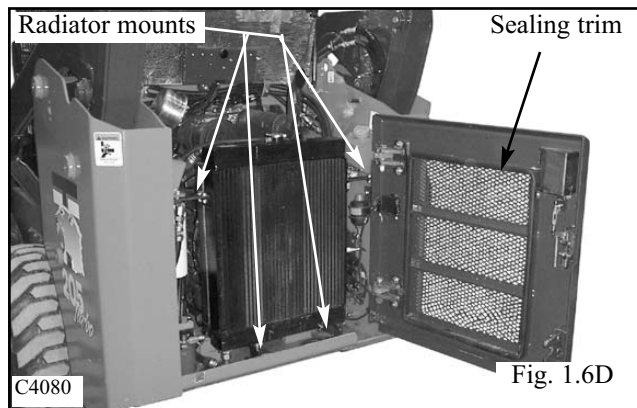
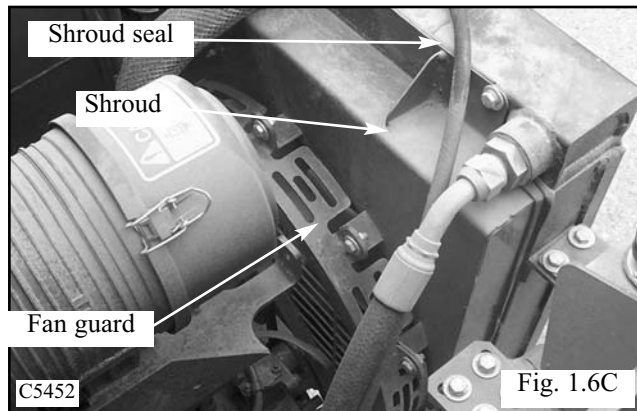
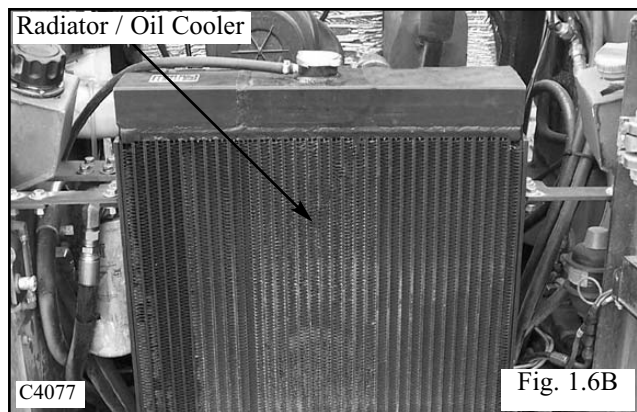
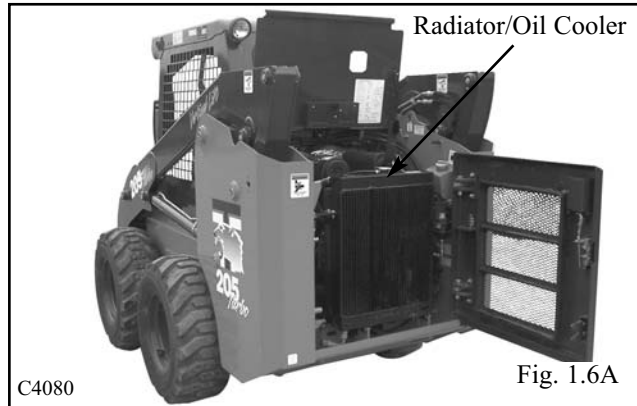

HYDRAULIC OIL COOLER 1.6

1

Cooler Replacement

The oil cooler is integral with the engine radiator and cannot be separated.

- 1 Lower the boom arms, engage the parking brake and shut off the engine.
- 2 Open the rear door and raise the engine cover to service the Radiator / oil cooler. (Fig. 1.6E)
- 3 Drain the engine coolant (Section 7.1). Loosen the clamps for the top and bottom rad hoses and remove hoses. Disconnect hose for coolant overflow jug.
- 4 Connect a vacuum system to the oil reservoir filler



WARNING

To prevent personal injury, do not attempt to lift heavy objects without assistance.

location. Drain the hydraulic oil reservoir if a vacuum is not available. If the drain plug is removed, seal the threads with teflon tape or a liquid form of pipe sealant. Be prepared to contain 17.4 gal of fluid (66 liters). Use clean containers if the oil is to be reused.

- 5 Tag all hose locations and take note of the hose routing. Remove the cooler hoses. Plug the open hoses and cooler ports to prevent contamination. (Fig. 1.6G)
- 6 Remove fan guard.
- 7 The radiator / oil cooler is very heavy (approx. 75 lbs) and will need some form of mechanical aid, such as an over head hoist to help service. Remove top rad/cooler

IMPORTANT

Cap all open lines and ports to prevent contamination.

mounts. Connect the hooks of the over head hoist in the top bolt holes of rad/cooler.

- 8 Remove the bolts from the lower rad mounts. Lift the rad/cooler clear of the loader.
- 9 Remove the 6 bolts on the shroud and remove the shroud. Inspect foam gasket and edge trim for damage. Replace as required.
- 10 Inspect the fitting o-rings for damage and replace if necessary.
- 11 Install the shroud, replace the fittings into the new or repaired oil cooler following the torque chart on section 1.10. Be sure to support the cooler as the fittings are tightened to prevent damaging the cooler.
- 12 Install the cooler, cooler lines and fan guard. Install the engine rad hoses and the overflow hose. Follow the torque chart on section 1.10 when tightening the hydraulic hoses. Re-fill rad with coolant, check hyd oil level. Adjust rad/cooler to seal properly against rear door.

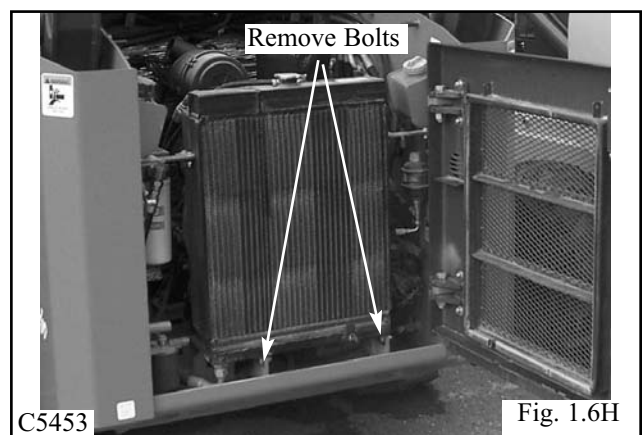
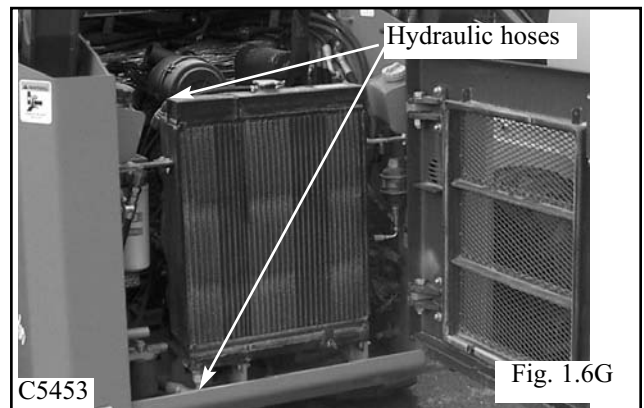
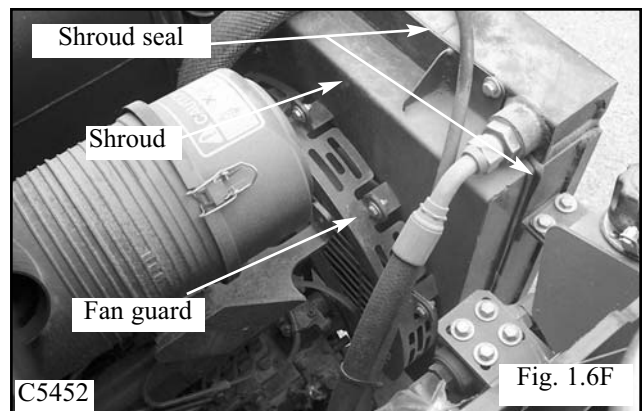
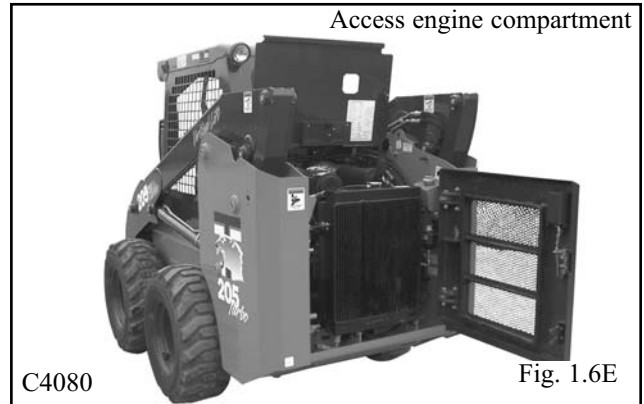

HYDRAULIC OIL RESERVOIR 1.7

1

General Information

The hydraulic oil reservoir is located at the rear of the loader on the left hand side. (fig. 1.7A) The reservoir is completely separated from all chain and gear drives to eliminate contamination. A magnetic drain plug is installed in the bottom of the reservoir, and a magnet is attached to the 100 micron suction filter, to assist in removing metal particles from the oil.

Oil level is checked through a sight gauge located just inside the engine compartment, left hand side, on the oil reservoir. The proper fill level is marked by a line and should be checked daily. (Fig. 1.7B)

The oil reservoir fill cap is located at the top of the reservoir inside the engine compartment. (Fig. 1.7C) The oil fill cap assembly has a 10 micron screen to catch larger particles of contaminant before entering the reservoir, but **always use oil filtered through a 5 micron min. filter for replenishing the hydraulic reservoir.** The oil fill cap is also a reservoir vent, or breather, and contains a 10 micron filter to remove air borne particles.

Checking The Oil Level

- 1 Check the reservoir oil level with the loader on level ground.
- 2 Lower the boom arms, retract the cylinders and engage the parking brake. Shut off the engine.
- 3 Open the rear door. Raise the engine cover to access the engine compartment (Fig. 1.7A)
- 4 Check the oil level in the sight gauge. (Fig. 1.7B)
- 5 If oil is visible approximately mid way in the sight gauge, the level is correct. The correct level is marked with a line from the factory.

Adding Oil

- 1 Remove the bolt, or lock, on the reservoir filler cap.
- 2 Open the filler cap. (Fig. 1.7C)
- 3 Inspect the filler screen in the filler neck for damage. If the filler screen is damaged, replace it.
- 4 Using a clean container, add 10W30 API class SJ.
- 5 Replace the filler cap and replace the bolt, or padlock, in the cap to prevent vandalism.

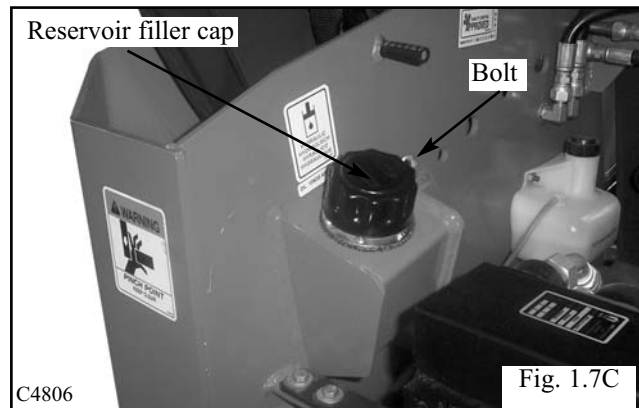
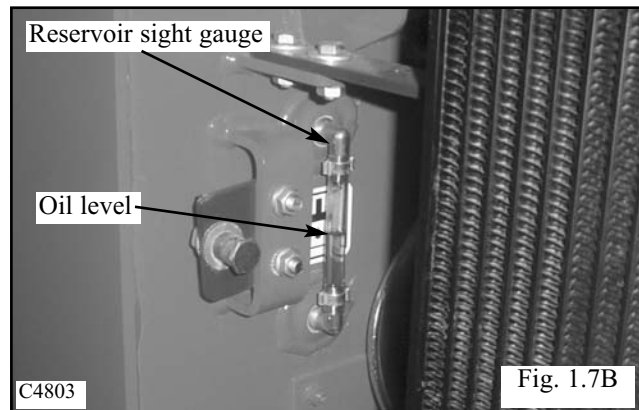
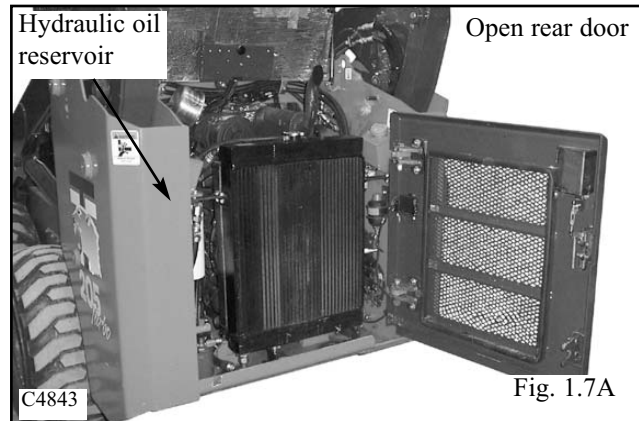

HYDRAULIC OIL RESERVOIR 1.7

1

Servicing The Oil Reservoir

Change the hydraulic oil, change the suction screen element and clean the magnet in the tank after every 1000 operating hours or if the oil has become contaminated or after any major hydrostatic drive system repair.

- 1 Lower the boom arms, shut off the engine and engage the parking brake.
- 2 Remove the magnetic drain plug (Fig. 1.7D) located at the bottom of the hydraulic oil reservoir. Clean any metal particles that may be attached to the magnet. Have containers ready to hold approximately 17.4 gallons (66 liters) of fluid. Replace the drain plug using teflon sealing tape or liquid type sealant on the plug threads.
- 3 Access the suction screen element in the hydraulic reservoir by removing the inspection cover on the reservoir, located in the engine compartment. (Fig. 1.7E) Clean the sealing area on the reservoir and cover.
- 4 Remove the suction screen element from the reservoir by turning counter clockwise. (fig. C3663, C3664)
- 5 Remove and clean the magnet attached to the suction element. (fig. C3663)
- 6 Install the magnet onto a new suction element and install the suction element.
- 7 Seal the inspection hole and install the inspection cover to the reservoir. Do not over tighten the mounting nuts. Maximum torque is 15 ft lbs (20 Nm).
- 8 Fill the reservoir to the proper level with 10W30 API classification SJ oil, approximately 17.4 gallons (66 liters).

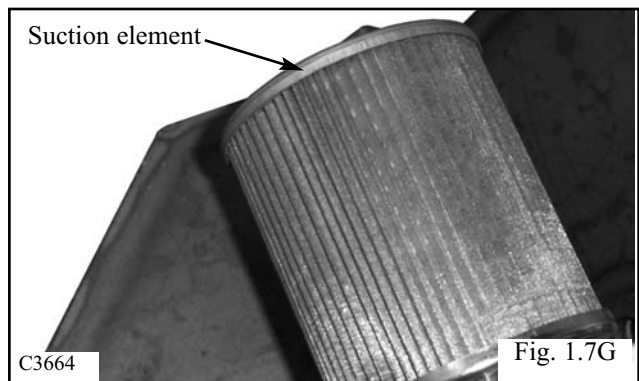
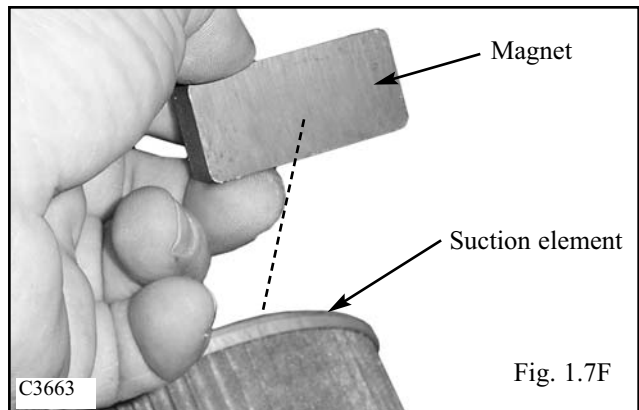
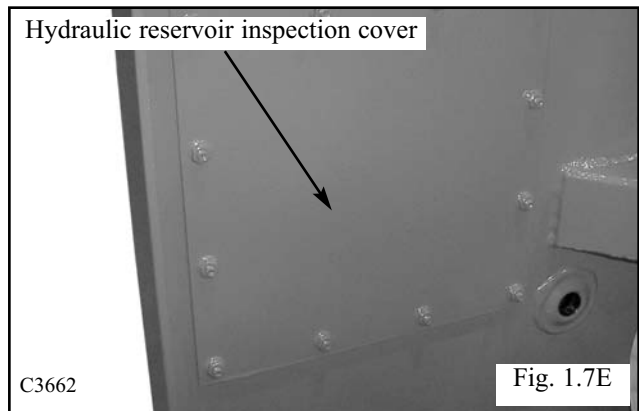
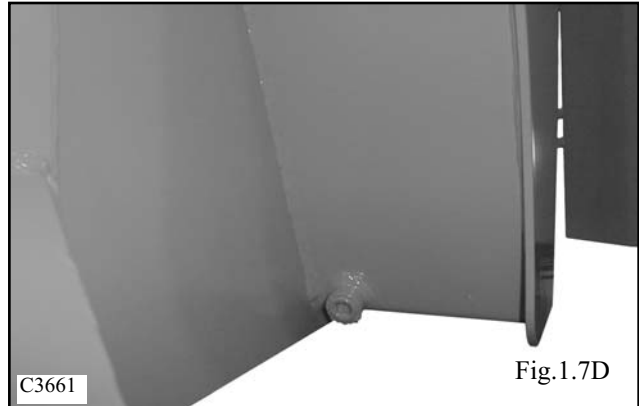

TROUBLE SHOOTING 1.8

1

Problem	Cause	Corrective Action	Section
Loss of hydraulic power (no flow from the gear pump).	Reservoir low on oil.	Check for leaks. Fill the reservoir to the proper level.	1.7
	Adapter kit between engine and tandem pump failure.	Inspect and replace the damaged parts as required. Check for proper alignment.	7
	Gear pump not functioning.	Inspect and replace damaged parts.	1.2 / 2.9
	Splined coupling failure in the hydrostatic pump	See the Sauer Sundstrand Repair Manual BLN 9989.	2.11
Loss of hydraulic power (full flow from gear pump).	Auxiliary hydraulics engaged.	Disengage the switch.	
	Relief valve failure or out of adjustment.	Check pressure. Adjust or repair as required.	1.3
	Control linkage disconnected or binding	Inspect, adjust or replace parts	4
Hydraulic action jerky.	Reservoir low on oil.	Check for leaks. Fill the reservoir to the proper level.	1.7
	Control linkages loose or worn.	Inspect, adjust or replace parts.	4
	Air in hydraulic system.	Check for leaks between the oil reservoir and pump.	
	Load check valve not functioning.	Inspect and replace damaged parts.	1.3
	Control valve spool spring return mechanism not functioning	Inspect and replace damaged parts.	1.3
Boom raises slowly at full rpm	Reservoir low on oil.	Check for leaks. Fill the reservoir to the proper level.	1.7
	Control linkages loose or worn.	Inspect, adjust or replace parts.	4
	Auxiliary hydraulics engaged.	Disengage the switch.	
	Lifting more than rated capacity.	Reduce the load.	
	Engine rpm too low.	Check engine rpm and reset.	
	Relief valve failure or out of adjustment.	Check pressure. Adjust or repair as required.	1.3
	Cylinder seal(s) failure.	Check seals.	1.4
	Internal leakage in the control valve.	Inspect the control valve and repair as required.	1.3
	Limiters on control cross shaft misadjusted	Inspect, adjust or replace parts.	4-2
Hydraulic cylinders will not support a load. (leak down)	Control valve spools not centering.	Check control linkage and control valve spool spring centering devise.	
	Cylinder seal(s) failure	Check seals.	1.4
	Load check valve not functioning.	Inspect and replace damaged parts.	1.3
	External leak between control valve and cylinders	Inspect and repair.	

TROUBLE SHOOTING 1.8

1

Problem	Cause	Corrective Action	Section
Hydraulic oil overheating.	Reservoir low on oil.	Check for leaks and replenish as required.	1.8
	Oil cooler plugged or dirty.	Clean the cooling fins.	1.7
	Auxiliary hydraulics engaged.	Disengage.	4.9
	Cooling fan damaged or inoperative	Check fan and drive belt	1.7
	Engine rpm too low.	Check engine rpm and reset.	7.11
	Temperature sender defective.	Replace.	8
	Relief valve failure or out of adjustment.	Check pressure, adjust or replace.	1.4
	Wrong type of hydraulic fluid.	Replace.	1.8

TORQUE CHART 1.9

Torque Chart NOTE: Multiply ft.lb. by 1.36 = N.m.

FITTING SIZE 37° JIC FITTINGS			FITTING SIZE ORB FITTINGS		
1/4	-4	9 to 10 ft.lb.	1/4	-4	14 to 16 ft.lb.
5/16	-5	15 to 16 ft.lb.	5/16	-5	18 to 20 ft.lb.
3/8	-6	20 to 22 ft.lb.	3/8	-6	24 to 26 ft.lb.
1/2	-8	30 to 33 ft.lb.	1/2	-8	50 to 60 ft.lb.
5/8	-10	40 to 44 ft.lb.	5/8	-10	72 to 80 ft.lb.
3/4	-12	70 to 77 ft.lb.	3/4	-12	125 to 135 ft.lb.
7/8	-14	82 to 90 ft.lb.	7/8	-14	160 to 180 ft.lb.
1	-16	94 to 104 ft.lb.	1	-16	200 to 220 ft.lb.
1 1/4	-20	120 to 132 ft.lb.	1 1/4	-20	210 to 280 ft.lb.
1 1/2	-24	131 to 144 ft.lb.	1 1/2	-24	270 to 360 ft.lb.
2	-32	300 to 330 ft.lb.			

The following torque specifications are for steel ORB fittings into aluminum.					
FITTING SIZE ORB FITTINGS			FITTING SIZE ORB FITTINGS		
1/4	-4	5 to 7 ft.lb.	3/4	-12	40 to 45 ft.lb.
5/16	-5	8 to 10 ft.lb.	7/8	-14	50 to 55 ft.lb.
3/8	-6	10 to 12 ft.lb.	1	-16	90 to 99 ft.lb.
1/2	-8	21 to 24 ft.lb.	1 1/4	-20	80to 90 ft.lb.
5/8	-10	27 to 30 ft.lb.			

CONVERSION CHART 1.10

CONVERSION FACTORS

Metric To Imperial

	MULTIPLY	BY	TO OBTAIN
Area:	sq. meter	10.763 91	square foot
	hectare	2.471 05	acre
Force:	newton	0.224 809	pound force
Length:	millimeter	0.039 370	inch
	meter	3.280 840	foot
	kilometer	0.621 371	mile
Mass:	kilogram	2.204 622	pound
Mass/Energy:	gm/kW-h	0.001 644	lbs/hp-h
Mass/Volume:	kg/cubic meter	0.06243	lb/cubic ft.
Power:	kilowatt	1.341 02	horsepower
Pressure:	kilopascal	0.145 038	lb/sq.inch
	bar	14.50385	lb/sq.inch
Temperature:	degree C	$1.8 \times C + 32$	degree F
Torque:	newton meter	8.850 748	inch pound
	newton meter	0.737 562	foot pound
Velocity:	kilometer/hr.	0.621 371	miles/hr.
Volume:	cubic centimeter	0.061 024	cubic inch
	cubic meter	35.314 66	cubic foot
	cubic meter	1.307 950	cubic yd.
	millimeter	0.033 814	ounce (US fluid)
	litre	1.056 814	quart (US liquid)
	litre	0.879 877	quart (Imperial)
	litre	0.264 172	gallon (US liquid)
	litre	0.219 969	gallon (Imperial)
Volume/Time:	litre/min.	0.264 172	gallon/min. (US liquid)
	litre/min.	0.219 969	gallon/min. (Imperial)

CONVERSION CHART 1.10

CONVERSION FACTORS Imperial To Metric

1

	MULTIPLY	BY	TO OBTAIN
Area:	sq. foot	0.092 903	square meter
	acre	0.404 686	hectare
Force:	pound force	4.448 222	newton
Length:	inch	25.4	millimeter
	foot	0.304 8	meter
	mile	1.609 344	kilometer
Mass:	pound	0.453 592	kilogram
	ounce	28.35	gram
Mass/Energy:	lb/hp-h	608.277 4	gm/kW-h
Mass/Volume:	lb/cubic ft.	16.0185	kg/cubic meter
Power:	horsepower	0.745 700	kilowatt
Pressure:	lbs/sq.in.	6.894 757	kilopascal
	lbs/sq.in.	0.069	bar
	lbs/sq.in.	0.070 303	kg/sq.cm
Temperature:	degree F	0.555 (F - 32)	degree C
Torque:	inch pound	0.112 985	newton meter
	foot pound	1.355 818	newton meter
Velocity:	miles/hr.	1.609 344	kilometer/hr.
Volume:	cubic inch	16.387 06	cubic centimeter
	cubic foot	0.028 317	cubic meter
	cubic yard	0.764 555	cubic meter
	ounce (U.S. fluid)	29.573 53	milliliter
	quart (U.S. liquid)	0.946 353	litre
	quart (Imperial)	1.136 523	litre
	gallon (U.S.)	3.785 412	litre
	gallons (Imperial)	4.546 092	litre
Volume/Time:	gallon/min.	3.785 412	litre/min.

NOTES

1



SECTION 2

HYDROSTATIC DRIVE SYSTEM

Hydrostatic Circuit	2.1
Hydrostatic Circuit & System Pressure	pg. 2-2
Specifications	pg. 2-3
General Information	2.2
Introduction	pg. 2-4
Trouble Shooting	2.3
Chart	pg. 2-5 ~ 7
Diagnose Steps	pg. 2-8
Pressure Tests	2.4
Procedure	pg. 2-9
Flushing The Hydraulic System	2.5
General Information	pg. 2-10
Cleaning	pg. 2-11 ~ 12
Start-up Procedure	2.6
Procedure	pg. 2-13
Gear Pump Replacement	2.7
Procedure	pg. 2-14
Tandem Pump Replacement	2.8
Procedure	pg. 2-15 ~ 18
Tandem Pump Parts Diagram	2.9
Parts Illustrations	pg. 2-19 ~ 22
Drive Motor	2.10
General Information	pg. 2-23 ~ 26
Removal	pg. 2-27 ~ 28
Replacement	pg. 2-29 ~ 30
Drive Motor	2.11
Disassembly	pg. 2-31 ~ 38
Assembly	pg. 2-39 ~ 43
Torque Specifications	2.12
Torque Chart	pg. 2-44



HYDROSTATIC CIRCUIT 2.1

Hydrostatic Circuit and System Pressure Schematic

- A** High Pressure Relief at 345 bar (5000 psi)
- B** Aux. Press. Relief Set at 3000 psi (207 bar)
- C** System Charge Pressure 260 psi Minimum (18 bar)
- D** Return Pressure
- E** Suction Line (Vacuum) 4 - 6 Hg @ 160°F (71°C)

2

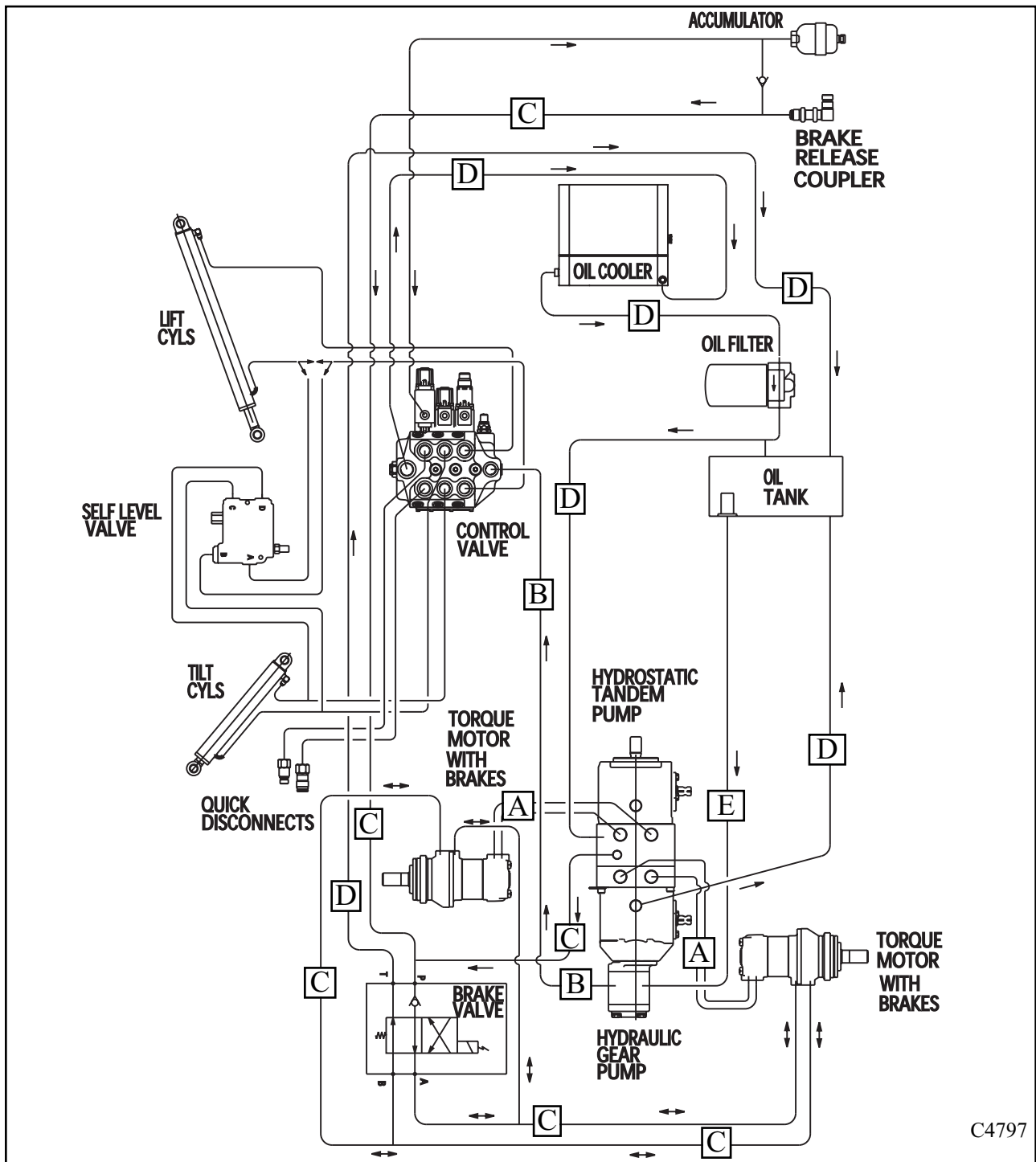

C4797

HYDROSTATIC CIRCUIT 2.1

Specifications

Hydrostatic Tandem Pump

Pump Type	Variable Displacement, Reversible Piston
Brand Name of Pump	Sauer-Danfoss
Series Type	40 / M44
No. Of Drive Pumps	2 (TWO)
Mounting	Tandem
Rotation (viewed from shaft end)	Clockwise
Operating Speed	2800 rpm (+ / - 50 rpm)
Pump Displacement	2.65 cu. in. (44cc)
Minimum Pump Output (flow)	17.1 gal. (64.7L) / Minute @ 1800 rpm @ 2000 psi (136.1 bar) Over Measured Charge Pressure
No. Of Relief Valves	2 (TWO)
Relief Valve Setting	345 bar (5000 psi)
Continuous Case Pressure	25 psi (1.7 bar)
Charge Pump Type	14.6 cc/rev. Geroter Style
Charge Pressure	260 psi (18 bar)
Hydrostatic Repair Manual	Thomas P / N 44232 Sauer Sundstrand P / N BLN-9992



Hydraulic Drive Motor

Drive Motor Type	Geroter Torque Motor With Brake
Brand Name	Sauer-Danfoss
Series Type	TMT 500 FLV
Rotation	Dual
No. Of Drive Motors	2 (TWO)
Drive Motor Displacement	31.9 cu. in. (523.6 cc)
Max. Case Pressure	250 psi (17.3 bar)

Reservoir

Fluid Type	10w30 API Class SJ Oil
Reservoir Filtration	One 100 Micron Screen Element
Hydraulic Oil Filtration	One 5 Micron Element
Hydraulic Element	P / N 35243

GENERAL INFORMATION 2.2

Introduction

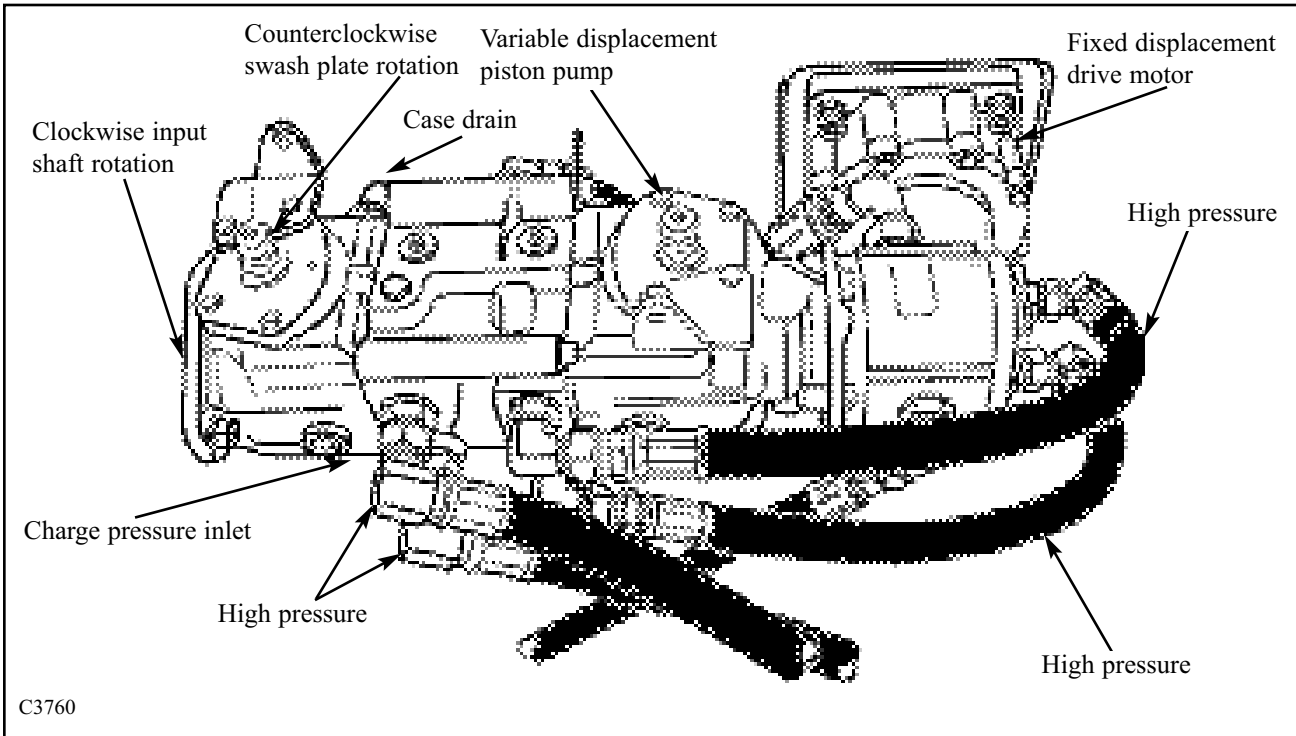

The driveshaft of the piston pump is rotated by the engine. The piston block which is splined to the driveshaft also turns. The piston block, rotating group, consists of 9 piston assemblies which have free swiveling shoes swagged on the ball end of each piston assembly. The shoe end of the piston rides against the smooth machined surface of the swashplate. With the swashplate in the neutral position, the piston assemblies do not reciprocate in the piston block, but are rotating. No oil is drawn into or discharged from the pump. The pump is in a zero displacement position and the loader remains stationary.

With the swashplate in the neutral position, the pressure of the charge oil, which ranges from 260 psi (18 bar), is able to unseat both check valves and supply oil to both sides of the pump because of the balance in pressure. Very little charge oil volume is required in the neutral position so the excess oil is bypassed over the charge pressure relief valve and recirculated back to the reservoir. The oil that leaks internally in the pump and motor collects in their body housings and is returned to the reservoir by external case drain in the pump and motors. This leakage oil is the only oil the charge check replenishes. This makes the design a closed loop system.

As the steering lever is moved forward, or reverse, the loader starts a directional movement. As the swashplate begins to move, the piston assemblies start to reciprocate in the piston block. As the steering lever continues further movement the cam angle increases, the pistons reciprocate further, more oil is pumped and the speed of the loader is increased.

When the swashplate begins to move the check valve on the discharge, or pressure, side seats because of the higher pressure differential. The other check valve remains open on the intake or low pressure side to continue supplying the closed loop system with charge oil.

The drive motor, which is a fixed displacement type, delivers a constant output torque for a given pressure throughout the speed range of the motor.

The movement of the pump swashplate, forward or reverse, controls the direction of the drive motor rotation.

The function of the pressure relief valve is to relieve the pressure side of the system of excessive high pressure when the loader encounters a heavy load or stalls out.

When the relief valve senses an over load it unseats, allowing excess pressure and volume to flow into the low pressure side of the pump. A small volume of oil starts to flow across to the other relief valve. This relief valve is exposed to the low pressure on the intake side of the pump and is seated by the spring tension within the relief valve body.

The small volume of oil being bypassed is enough to unseat the relief valve and let it recirculate back into the inlet side of the pump. As the pressure continues to build on the pressure side, a larger volume of oil flows and at a greater speed through the drilled orifice in the relief valve cartridge, causing a pressure drop inside the relief valve. The surrounding pressure is now able to unseat the relief valve and bypass maximum volume of oil. The system reliefs function the same for both sides of the system.

TROUBLE SHOOTING 2.3

Symptom: Neutral Difficult Or Impossible To Find

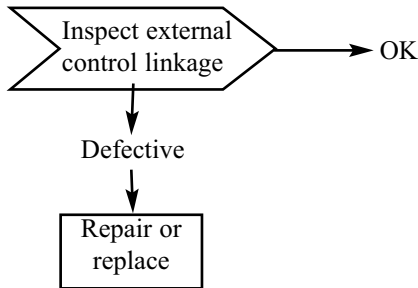

2

Symptom: System Operating Hot

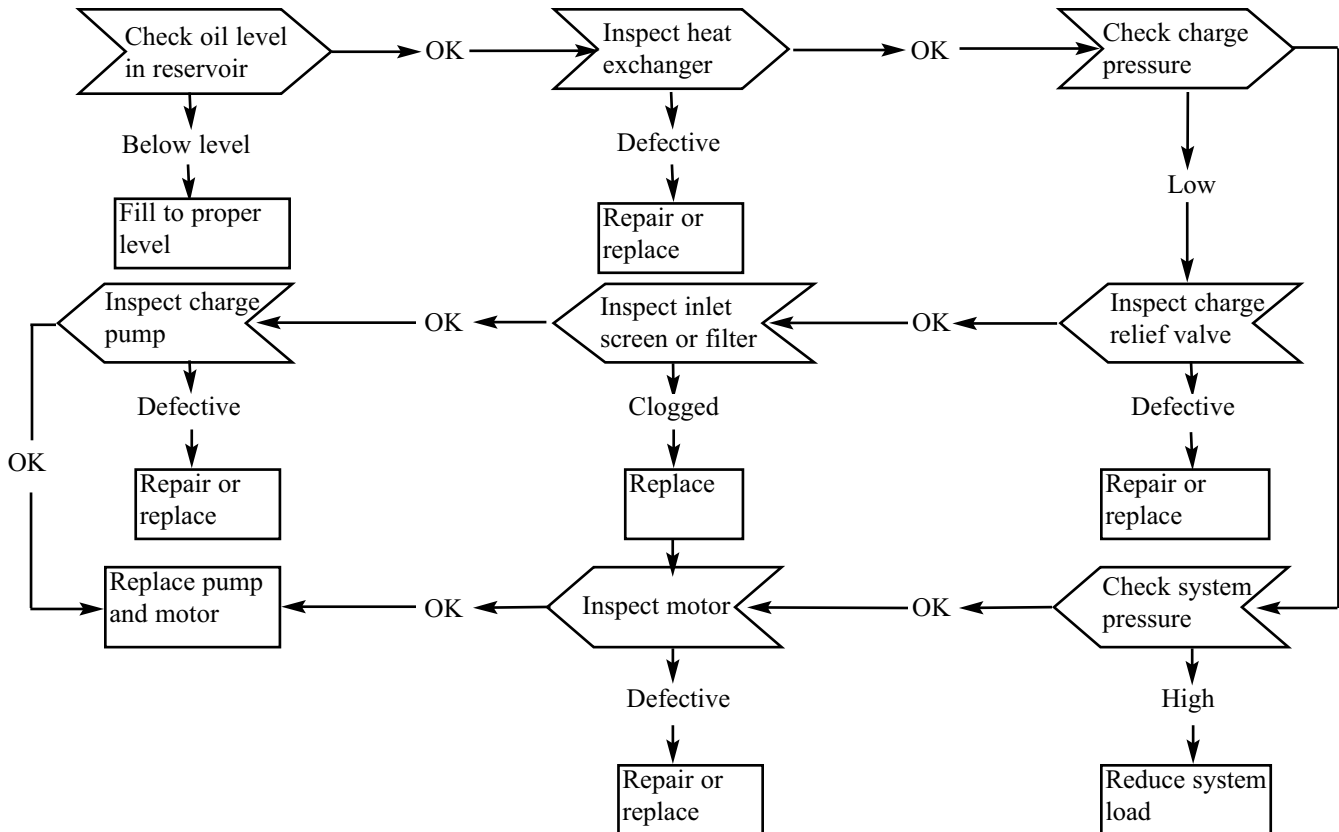

TROUBLE SHOOTING 2.3

Symptom: Operates In One Direction Only

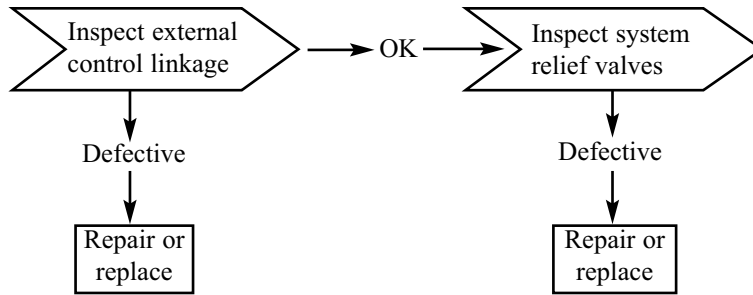

Symptom: System Response Sluggish

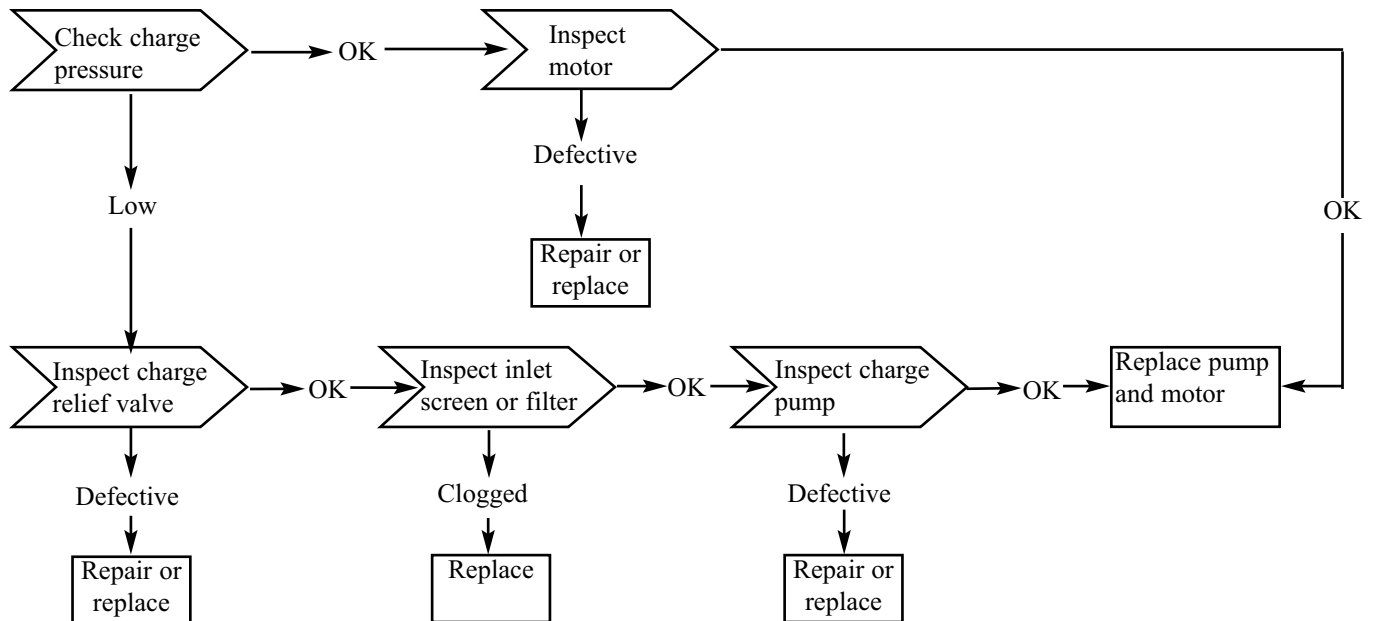

TROUBLE SHOOTING 2.3

Symptom: System Will Not Operate In Either Direction

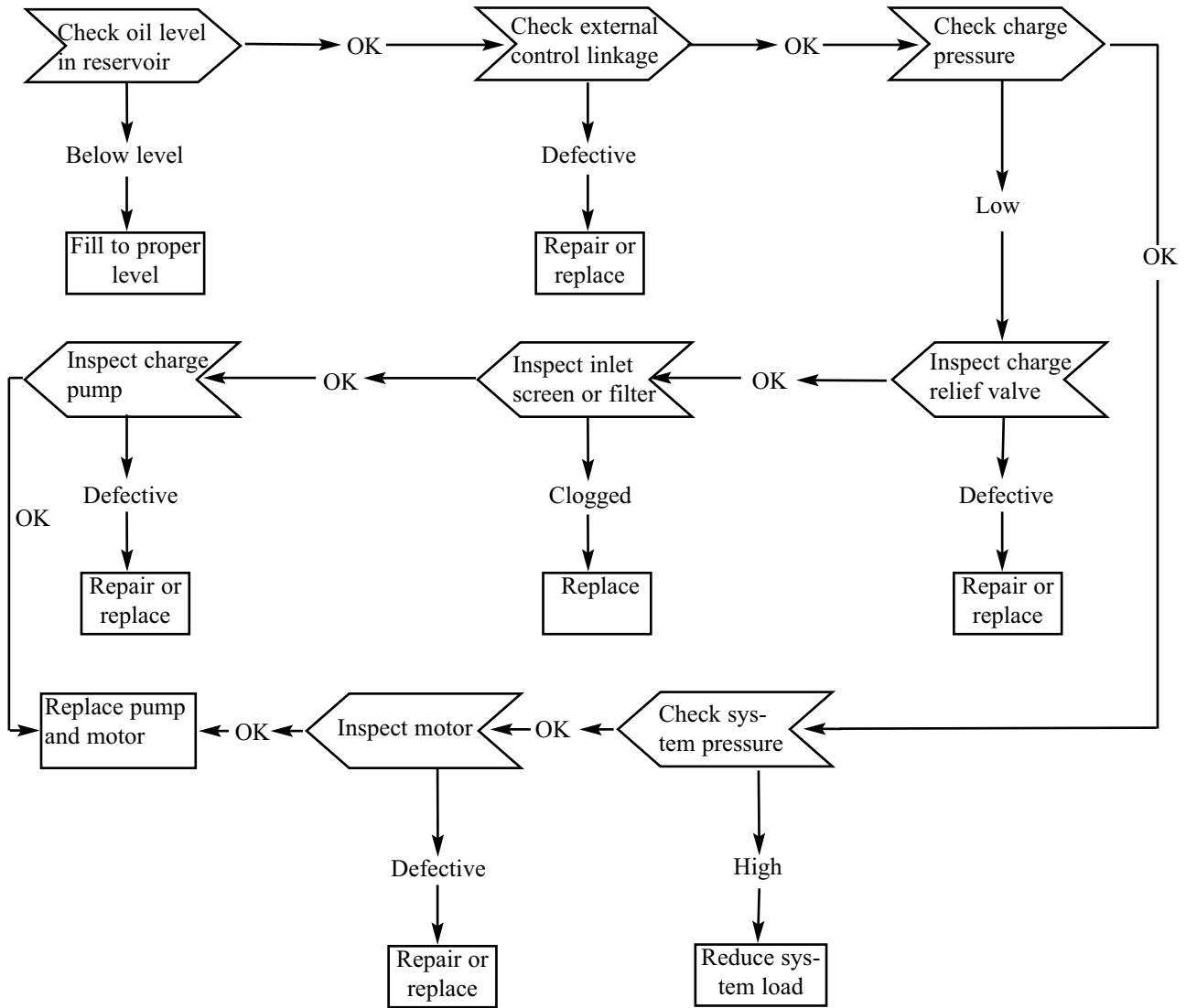

2

TRUBLE SHOOTING 2.3

System Diagnosing Steps And Special Tools

2

- 1 Check oil level in reservoir:**
 - a. fill to proper level as marked on site tube.
- 2 Inspect external control linkage for:**
 - a. Incorrect adjustment or disconnection
 - b. binding, bending or breakage
 - c. incorrectly adjusted, damaged or broken hydroback
- 3 Inspect servo control valve for: (if used)**
 - a. proper inlet pressure
 - b. Incorrectly adjusted or damaged neutral return spring
 - c. galled or stuck control spool
 - d. galled or stuck servo piston
- 4 Inspect heat exchanger for:**
 - a. obstructed air flow
 - b. improper plumbing (inlet to outlet)
 - c. obstructed fluid flow
- 5 Inspect inlet filter or screen for:**
 - a. plugged or clogged screen or filter
 - b. obstructed inlet or outlet
 - c. open inlet to charge pump (open line)
- 6 Check charge pressure:**
 - a. follow test procedures section 2.5
- 7 Inspect charge relief valve for:**
 - a. poppet held of seat
 - b. damaged or broken spring
 - c. damaged valve seat
 - d. improper charge relief setting
- 8 Inspect charge pump for:**
 - a. broken or missing drive coupling
 - b. damaged or missing o-rings
 - c. galled or broken geroter set
- 9 Inspect system relief valves for:**
 - a. damaged or broken springs
 - b. valve held of seat
 - c. damaged valve seat
 - d. improper pressure relief settings
- 10 Check system pressure:**
 - a. follow test procedures section 2.5
- 11 Inspect hydraulic motor for:**
 - a. disconnected coupling

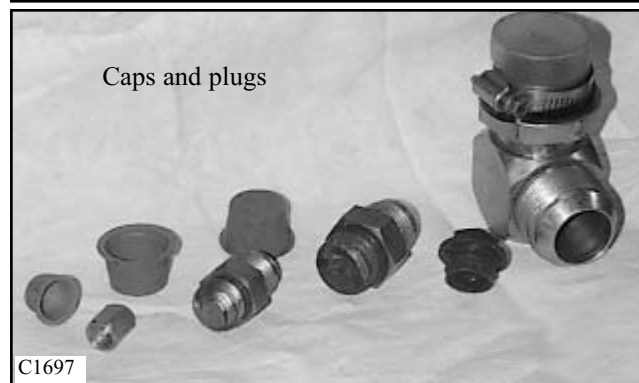
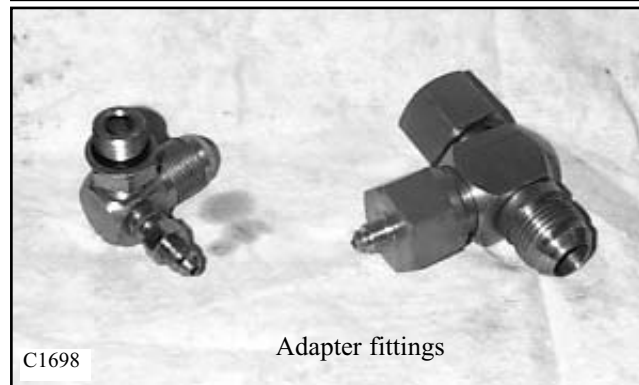
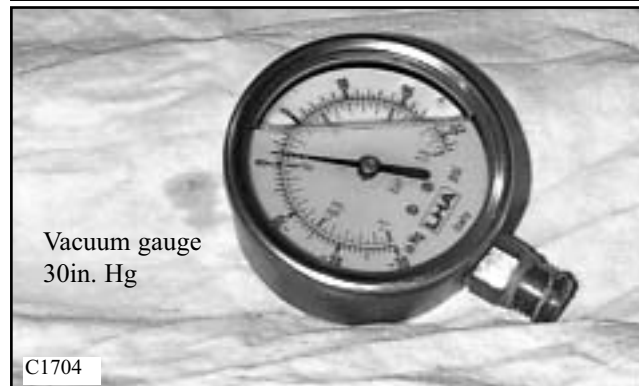
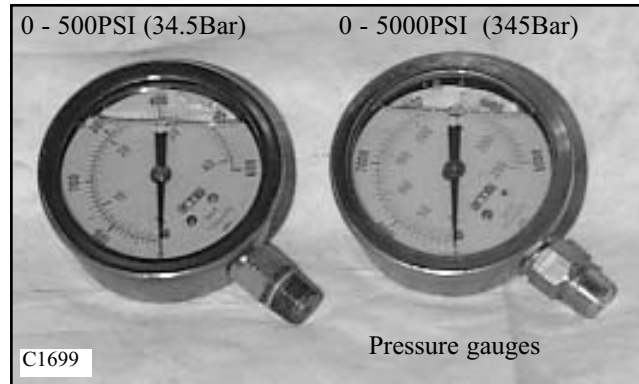

Photographs in the right hand column show some of the special tools that may be required to diagnose and repair the hydrostatic system.

PRESSURE TESTS 2.4

The following photos show the various port locations available on the hydrostatic tandem pump for checking system pressure.

Completing these pressure test will diagnose any mechanical problem in the hydrostatic system.

WARNING

Use caution when dealing with hydraulic fluid under pressure. Escaping fluid under pressure can penetrate the skin and cause serious injury.

Installing a gauge into the system gauge ports 'A', 'B', 'C', or 'D' will verify the status of the high pressure relief valves.

Checking the pressure at port 'E' will give accurate charge pressure reading.

Checking the pressure at port 'F' will verify case drain pressure.

Measuring the vacuum at the charge pump inlet can help locate the inlet lines and filters. It would be necessary to tee into the charge pump line fitting.

Snubbers are recommended to protect the gauges from pressure spikes. Frequent gauge calibration is necessary to insure accuracy.

Gauge Information		
A	System Pressure Gauge	10,000 PSI Gauge (690 Bar) 9/16 - 18 O-Ring Fitting
B	System Pressure Gauge	10,000 PSI Gauge (690 Bar) 9/16 - O-Ring Fitting
C	System Pressure Gauge	10,000 PSI Gauge (690 Bar) 9/16 - O-Ring Fitting
D	System Pressure Gauge	10,000 PSI Gauge (690 Bar) 9/16 - O-Ring Fitting
E	Charge Pressure Gauge Port	500 PSI Gauge (34.5 Bar) 7/8 - 14 O- Ring Fitting
F	Case Drain Port	500 PSI Gauge (34.5 Bar) 1 - 1/16 - 12 O-Ring Fitting
G	Charge Pump Inlet Vacuum	Vacuum Gauge (30 in. Hg) Tee Into Charge Pump Inlet

Tandem pump flow can also measure pump performance.

- 1 Connect a flow meter between the high pressure ports, one section at a time.
- 2 Start the engine and increase operating speed between 1775 ~ 1800 RPM.
- 3 Restrict the flow to show 2000 PSI (137.8 Bar) over charge inlet pressure.

Example: Charge pressure = 220 PSI (15.2 Bar) Gauge pressure reading would need to be 2220 PSI (153 Bar).

- 4 Minimum flow reading should be 17.1 gal / min. (64.7 L / min).

LH side and top view

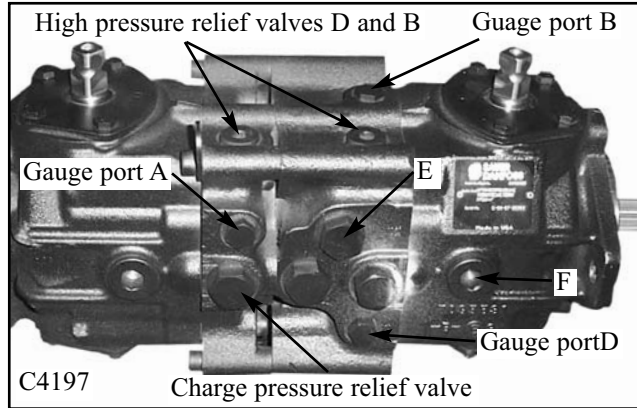

NOTE: Internal charge pump model shown

RH side and bottom view

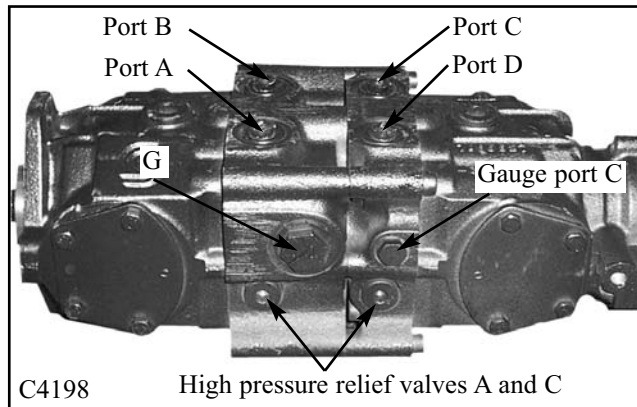

WARNING

Raise the machine securely from the ground before performing system checks to prevent sudden movement.

2

FLUSHING THE HYDRAULIC SYSTEM 2.5

General Information

2

Contamination in the hydraulic system is a major cause of component failure. Contamination can enter the hydraulic system in any of the following ways:

- 1 When draining the hydraulic system.
- 2 When disassembling components.
- 3 Making auxiliary connections with dirty couplers.
- 4 Normal component wear.
- 5 Component failure

The best way to remove contaminants from the hydrostatic drive system is to disassemble each component and flush and clean thoroughly.

The hydraulic control circuits may be cleaned by attaching a suitable hydraulic filter to the auxiliary couplings and circulating the fluid through it.

Contamination Types

There are 2 types of contamination, microscopic, or non visible, and visible. Microscopic contamination is suspended in the fluid and moves freely through the hydraulic circuits. Examples of problems caused by microscopic contaminants include the following:

- 1 Cylinder rod seal leaks.
- 2 Control valve spools do not return to neutral.
- 3 Hydraulic system has a high operating temperature.
- 4 Components wear rapidly.

Visible contamination is foreign material that can be found by sight, touch or odor. Some examples of visible contamination include the following:

- 1 Particles of metal or dirt in the oil.
- 2 Air in the oil.
- 3 Odor of burned oil.
- 4 Water in the oil.

FLUSHING THE HYDRAULIC SYSTEM 2.5

Cleaning The System

The first step in cleaning the hydraulic system is to determine if you have visible or microscopic contamination.

If the contamination is visible, do the following steps:

- 1 Change the hydraulic oil by removing the drain plug in the bottom of the hydraulic oil reservoir. (Fig. 2.5A) Be prepared to contain approximately 17.4 gal (66 litres) of fluid.
- 2 Check the extent of the contamination by disassembling 1 each of the hydraulic cylinders. Check the cylinders for damage. Repair or replace the cylinders as required. If you determine the damage was caused by severe contamination and is not the result of normal wear, it will be necessary to remove, clean and repair all valves, pumps, lines, cylinders, etc.
- 3 Replace all hydraulic filters.

If the contamination is determined to be microscopic, perform the following steps:

- 1 Change the hydraulic oil by removing the plug in the bottom of the oil reservoir. (Fig. 2.5A) Be prepared to contain approximately 17.4 gal (66 liters) of fluid.
- 2 Connect an external 5 micron filtering system, capable of sustaining minimum of 2000 psi (138 bar) and has a back pressure gauge (Fig. 2.5C), to the auxiliary couplings. (Fig. 2.5B)
- 3 Start the engine and let it idle at approximately half throttle.



WARNING

Be sure to use a filtering system capable of handling the pressure of the hydraulic system.

4 Engage the auxiliary circuit. Check to make sure the filtering system is not over taxed by the loaders hydraulic system pressure. Adjust engine idle accordingly to match the filtering systems capacity. This may vary as the filter becomes dirty, you may need to decrease engine rpm. Circulate the oil through filter for 30 minutes.

5 As the oil is being circulated through the auxiliary circuit, raise the liftarms up and down in full stroke cycles. Repeat this exercise for 15 minutes.

6 Cycle the bucket tilt cylinders in the same manner as above. Repeat the exercise, in full extension and retraction, for 15 minutes.

7 Install new hydraulic oil filters. (Fig. 2.5D)

8 Start the engine and check for leaks. Replenish the hydraulic oil reservoir as required. (Fig. 2.5E)

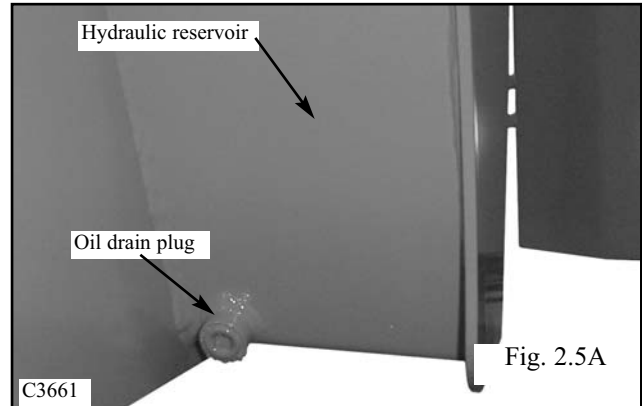

Fig. 2.5A

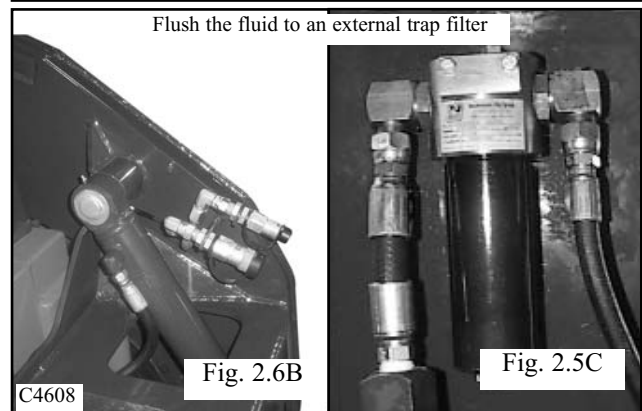

Fig. 2.5B

Fig. 2.5C

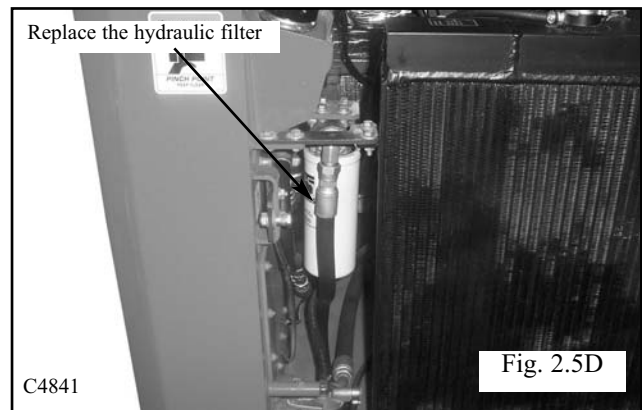

Fig. 2.5D

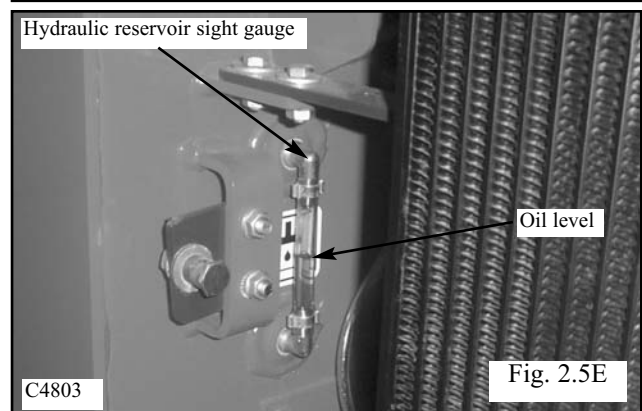

Fig. 2.5E

FLUSHING THE HYDRAULIC SYSTEM 2.6

For flushing water from the hydraulic system, perform the following procedures:

- 1 Remove any attachment.
- 2 Make sure all cylinders are fully retracted.

IMPORTANT

Be sure attachments are removed and liftarm are in the lowered position.

- 3 Change the hydraulic fluid. (Fig. 2.5F)
- 4 Change the hydraulic filter. (Fig. 2.5G)
- 5 Disconnect the hydraulic lines from one set of cylinders. (Fig. 2.5H, 2.5I)
- 6 Start the engine and set to the lowest idle.
- 7 Have someone hold the open hydraulic lines into a container. Stroke the foot pedals, or hand operated, controls slowly. Continue to repeat this cycle until the oil comes out clear. Repeat for opposite set of cylinders.



WARNING

Use caution when dealing with hydraulic fluid under pressure. Escaping fluid under pressure can penetrate the skin and cause serious injury.

- 8 Attach a hose and couplings to the auxiliary circuit. Engage the auxiliary hydraulics, forward and reverse, until the oil flows clear.
- 9 Connect 1 hose each, on each cylinder, to the fixed end of the cylinder barrel.

IMPORTANT

Check the hydraulic oil frequently during this procedure. Replenish as required.

- 10 Move the foot pedal or control lever to extend the cylinder rods. This will flush the oil from inside the cylinder barrels. Be prepared to contain the waste oil.
- 11 Stop the engine.
- 12 Connect the hydraulic hoses to the rod end of the cylinder barrel.
- 13 Replenish the hydraulic oil as required.

IMPORTANT

Please contain and dispose of waste oil in an environmentally friendly manner.

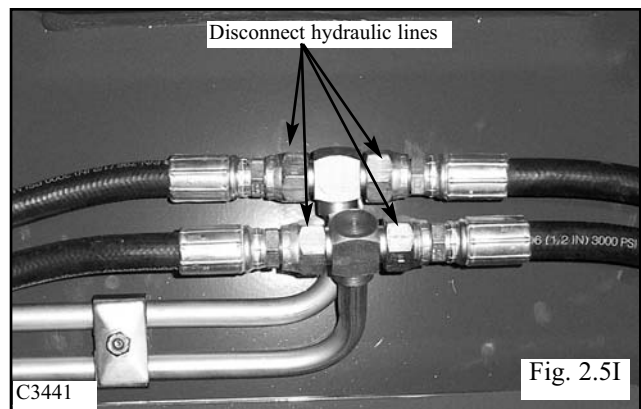
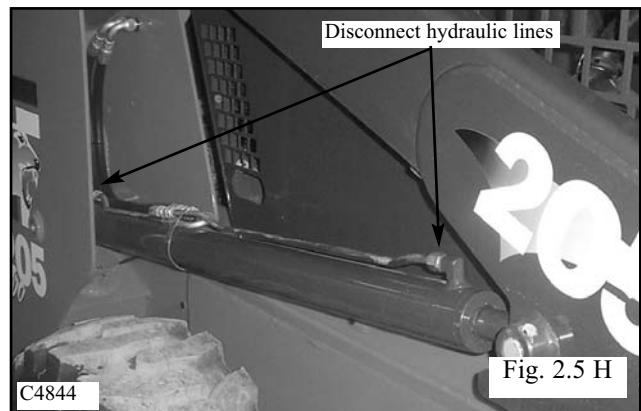
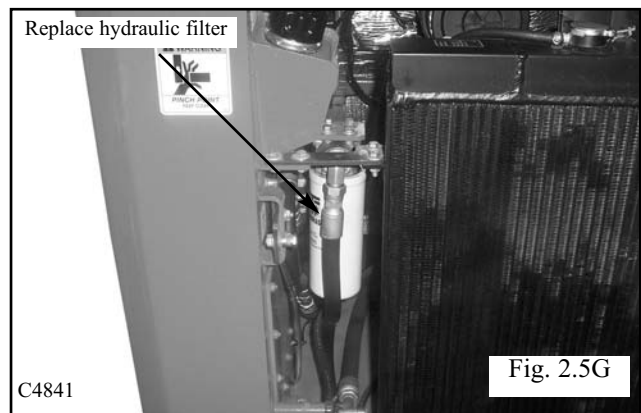
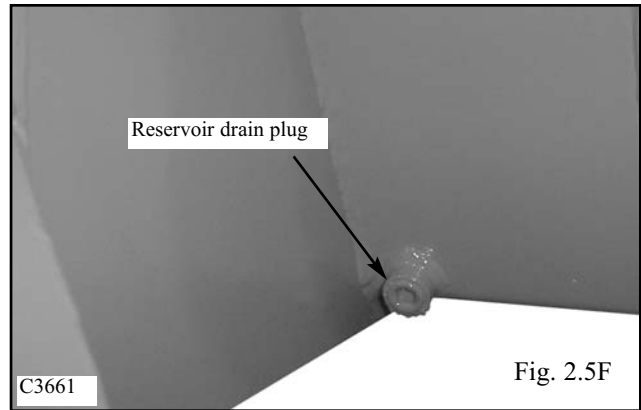

START-UP PROCEDURE 2.6

The following start-up procedure should always be adhered to when starting up a new installation or when restarting after pump repairs have been made.



WARNING

This start-up procedure must be made with the loader securely raised off the ground.

- 1 Fill the hydraulic oil reservoir to the proper level. (Fig. 2.6E)
- 2 Check inlet and pressure hoses and fittings for proper tightness prior to starting. Make sure all line are free of restrictions and air leaks.
- 3 The pump must be filled prior to start-up with filtered oil. Fill the pump by pouring oil into the charge pump inlet port. (Fig. 2.6A location "E") In the case of this loader, the inlet hose is filled by gravity from the tank. The fitting should be loosened to double check that oil is present.
- 4 Disconnect the engine stop solenoid wiring, or remove the fuse connected to the red wire. (Fig. 2.6B, 2.6C)
- 5 Turn the engine over by engaging the starter. Repeat this step, turning the engine over in 15 second interval, 5 or 6 times. This will fill the rest of the hydraulic hoses.
- 6 Reconnect the engine stop solenoid or replace the fuse.



WARNING

Use caution when dealing with hydraulic fluid under pressure. Escaping fluid under pressure can penetrate the skin and cause serious injury.

- 7 Place a gauge on the charge pressure port gauge to monitor the charge pressure during start up. Start the engine and let idle at lowest possible setting. The charge pressure should establish itself to 260 psi (18 bar). Excess air may be bled from the high pressure lines through the high pressure gauge ports if required.
- 8 Check for leaks and make adjustments as required. Do not use your hands to check for leaks while the engine is operating.
- 9 Increase the rpm to half throttle. Bring the hydraulic fluid up to operating temperature. Check the pump for operation on the drive circuit in both forward and reverse operation. Stop the engine and remove the gauge on the quick coupler if the charge pressure is established to 260 psi (18 bar).
- 10 Replenish the hydraulic oil reservoir as required. (Fig. 2.6D, 2.6E) Adjust the controls as required. See section 4.

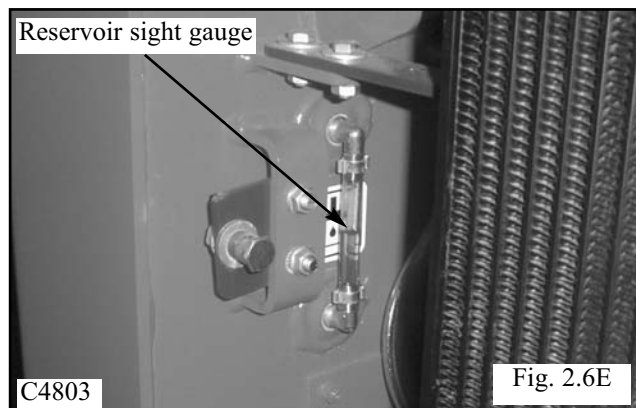
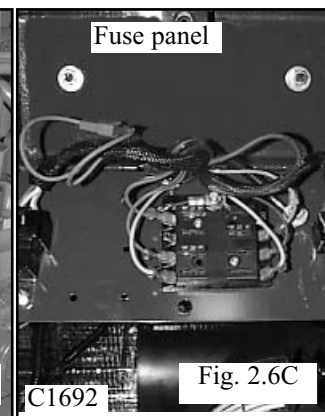
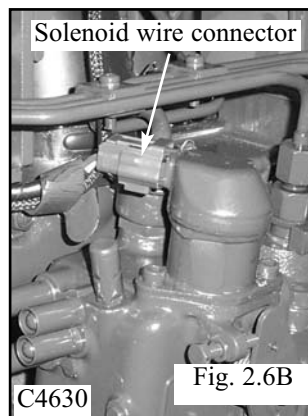
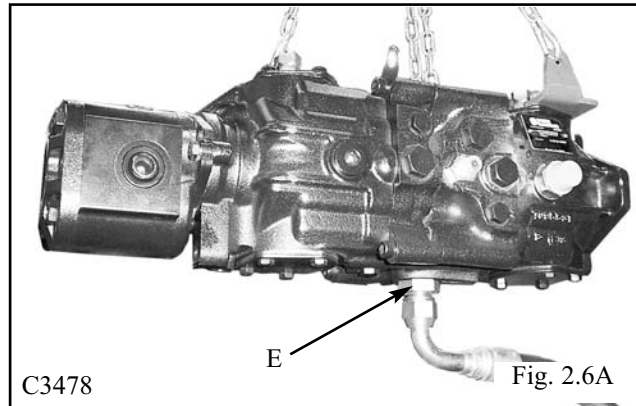

2

GEAR PUMP REPLACEMENT 2.7

Start the gear pump removal procedure by removing any attachment, raising the boom arms and engaging the boom support pins. Shut off the engine.



WARNING

To prevent personal injury do not work under the boom arms without the boom supports engaged.

- 1 Remove the seat and hydrostatic shield.
- 2 Attach a vacuum system to the hydraulic oil reservoir filler location. (Fig. 2.7A) Drain the oil reservoir if a vacuum is not available. Seal the threads on the drain plug with teflon tape or a liquid form of pipe sealant before reinstalling.
- 3 Disconnect the hydraulic hoses from the gear pump. (Fig. 2.7B) Remove the pump fittings. Cap all open hoses to prevent contamination. After capping ends you may unhook vacuum system from oil reservoir.
- 4 Remove the 2 bolts holding the gear pump to the hydrostatic tandem section. (Fig. 2.7C) Remove the gear pump unit.

IMPORTANT

If gear pump replacement is being done because of failure, the hydraulic system and oil should be checked for contamination.

- 5 Inspect the drive coupler for signs of wear and replace if required. Install a new O ring on the sealing area of the gear unit.



WARNING

Use caution when dealing with hydraulic fluid under pressure. Escaping fluid under pressure can penetrate the skin and cause serious injury.

- 6 Replace gear pump in reverse order. Torque the mounting bolts to 30 ft lbs (41 Nm) upon reassembly.
- 7 If the hydraulic system has been contaminated by pump or other failure you must follow the cleaning procedure outlined in section 2.6.
- 8 Start the engine and check for leaks. Do not use your hands to find leaks.
- 9 Check the fluid level in the hydraulic oil reservoir and replenish as required. (Fig. 2.7D)

IMPORTANT

When making repairs to the hydraulic system, keep the work area and parts clean. Use caps and plugs on all open lines and ports.

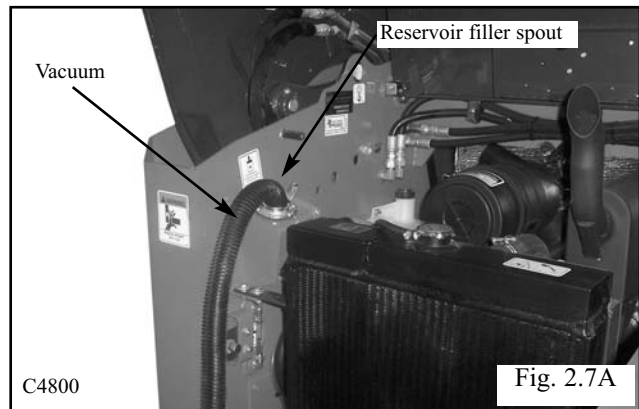

Fig. 2.7A

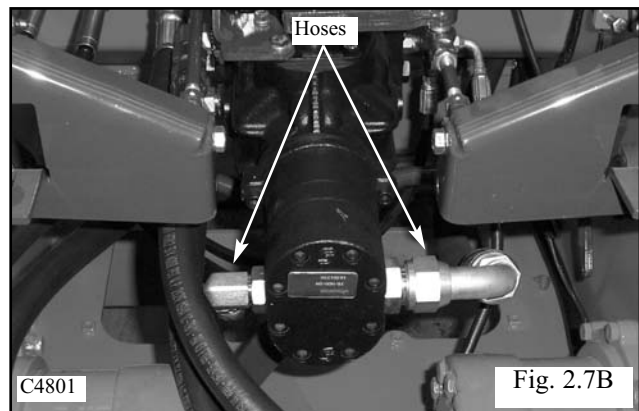

Fig. 2.7B

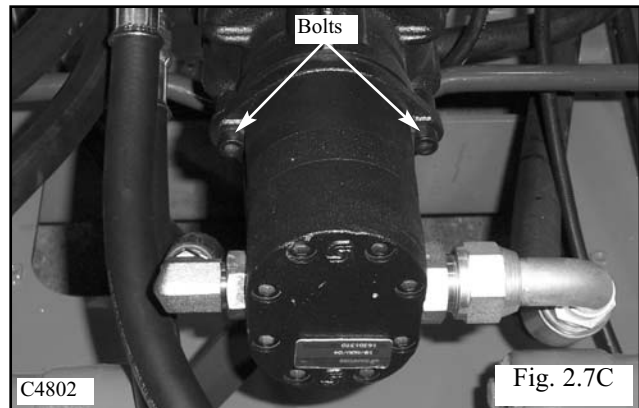

Fig. 2.7C

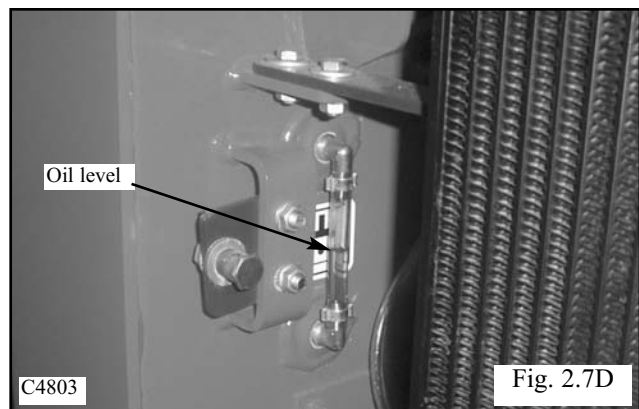

Fig. 2.7D

TANDEM PUMP REPLACEMENT 2.8

Begin the pump removal by removing any attachment, raise the boom arms and engage the boom support pins. Shut off the engine.



WARNING

To prevent personal injury do not work under the boom arms without the boom supports engaged.

- 1 Remove the seat and hydrostatic shield.
- 2 Remove the steering lever linkage, pintle levers and hydrobacks with mounts. Refer to section 4 for removal and replacement information. (Fig. 2.8A)
- 3 Remove the gear pump as outlined in section 2.8 if required.
- 4 Disconnect all the hydraulic hoses. Mark hose and fitting location if necessary to ease re-assembly. Upon re-assembly, torque the hydraulic fittings and hoses as outlined in the Torque Chart in Section 2.12 Cap all open lines and ports.
- 5 Remove fittings from the tandem pump to prevent damage while removing pump. Plug all open ports and keep the fittings in a clean area. Inspect fittings and o-rings for damage, replace as required.
- 6 Remove the mounting bolt on the tandem pump support mounting bracket. (Fig. 2.8B)
- 7 Remove the 2 bolts on the u-joint access panel (Fig. 2.8C) to gain access to the rear mounting bolts for the tandem pump. Tip the top of the panel rearward and pull the panel forward to remove.

IMPORTANT

When making repairs to the hydraulic system, keep the work area and parts clean. Use caps and plugs on all open lines and ports.

- 8 Attach a lifting device to the tandem pump. The pump is fairly heavy, approximately 80 lbs. (36 Kg) It is highly recommended to use a mechanical lifting device to assist removal of the tandem pump.
- 9 Remove the 2 rear mounting bolts by access through the u-joint access panel and remove the front mounting bracket. Remove tandem pump from the loader. (Fig. 2.8D)



CAUTION

To prevent possible personal injury, do not attempt to lift heavy objects without assistance.

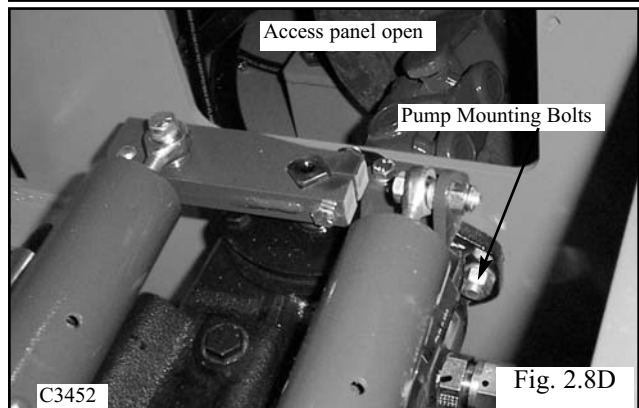
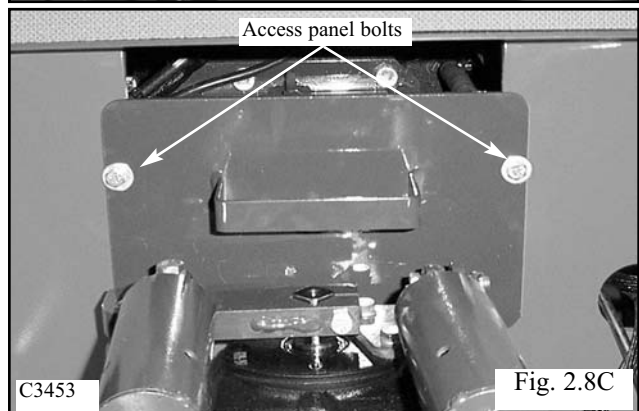
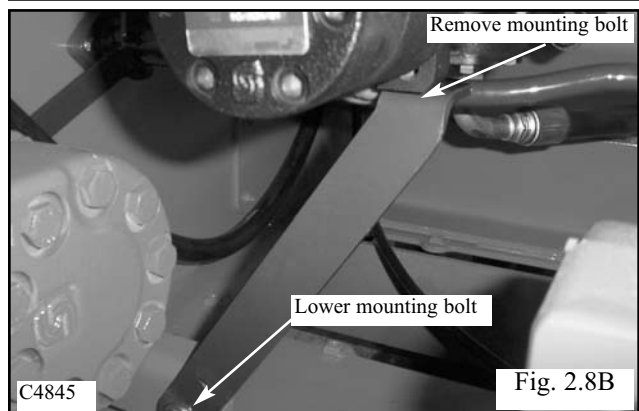
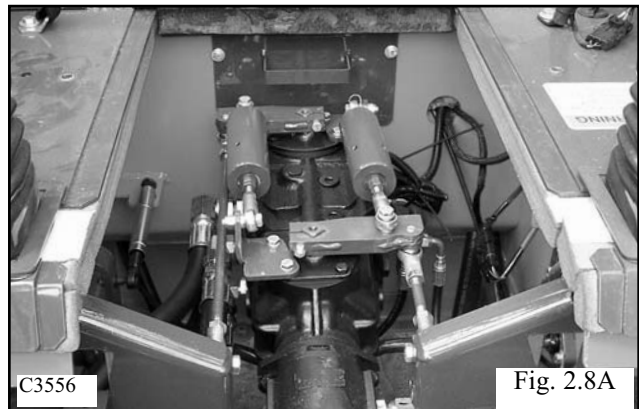

2

TANDEM PUMP REPLACEMENT 2.8

Upon reassembly, inspect the outside area of the tandem pump housing for damage that may have occurred in transit or handling.

- 1 Attach a lifting device to the tandem pump.
- 2 Install the charge pump inlet fitting and hose to the tandem pump. (Fig. 2.8E) Torque the fittings and hoses according to the Torque Chart in Section 2.12 page 2 - 45.
- 3 Install the tandem pump to the loader.



WARNING

To prevent personal injury, do not attempt to lift heavy objects without assistance.

- 4 Line up the u-joint to the tandem pump input splined shaft as you guide the pump into it's mounting location. (Fig. 2.8F)
- 5 Install the 2 rear mounting bolts.
- 6 Line up the pump support mounting brace holes and install the bolt. (Fig. 2.8G)
- 7 Torque the 2 rear mounting bolts to 60 ft lbs. (82 Nm) Torque the front lower mounting bracket bolt at 20 to 25 ft lbs. (27 to 34 Nm) Remove the lifting device.

8 Connecting the 4 high pressure drive hoses and fittings to the tandem pump can only be accomplished in a certain sequence. (Fig. 2.8H) Follow the Torque Chart in Section 2.12, page 2 - 45 when tightening fittings and hoses. If you have removed the hoses completely use the following pattern to reconnect:

- A Hose no. 4 connects to the bottom port of the right hand drive motor.
- B Hose no. 1 connects to the bottom port of the left hand drive motor.
- C Hose no. 2 connects to the top port of the left hand drive motor.
- D. Hose no. 3 connects to the top port of the right hand drive motor.

IMPORTANT

When making repairs to the hydraulic system, keep the work area and parts clean. Use caps and plugs on all open line and ports

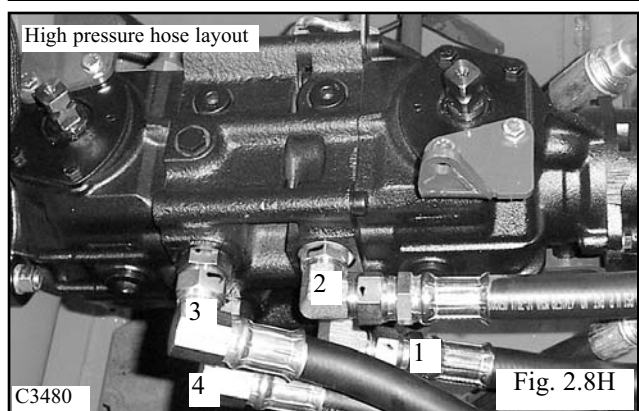
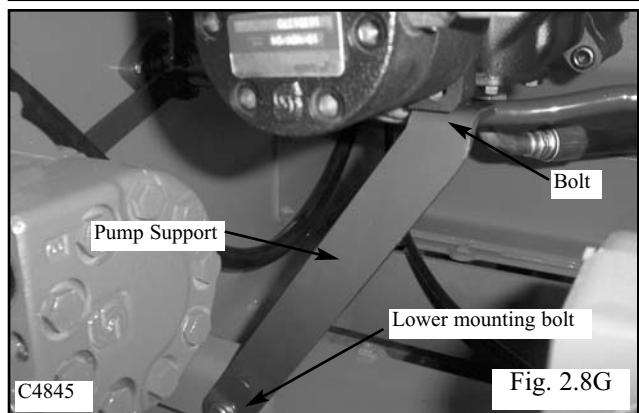
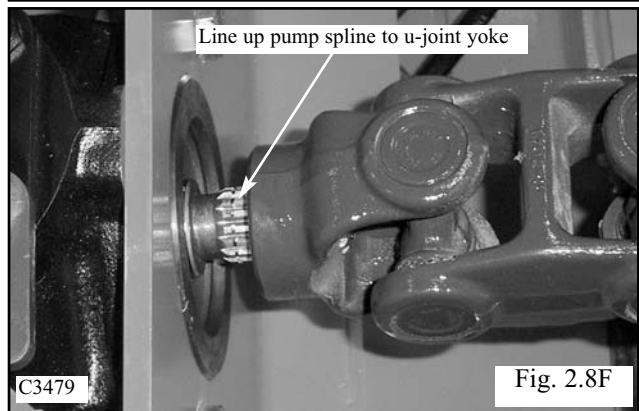
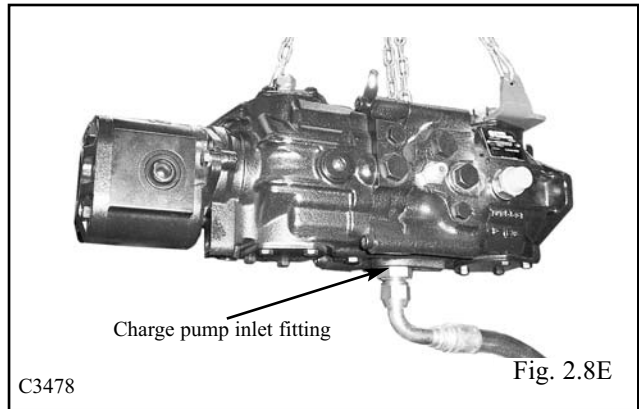

TANDEM PUMP REPLACEMENT 2.8

9 Connect the tandem pump case drain fitting and hose. Torque the fittings and hoses to the specifications listed in the Torque Chart in Section 2.13 page 2 - 43.

IMPORTANT
When making repairs to the hydraulic system, keep the work area and parts clean. Use caps and plugs on all open line and ports.

10 Connect the charge pressure fitting and tee fitting to the tandem pump. Connect the hose from the charge pressure coupling and the hose to the brake valve to the tee fitting (Fig. 2.8I). Torque the fittings and hoses to the specifications listed in the Torque Chart in section 2.12 page 2-45.

11 Connect the auxiliary gear pump outlet fittings and hoses to the gear pump. (Fig. 2.8J) Follow the Torque Chart in Section 2.12 page 2 - 45 when tightening fittings and hoses.

IMPORTANT
Inspect fitting o-rings and flares for marks or damage. Replace if necessary.

12 Connect the inlet fitting and hose to the auxiliary gear pump. (Fig. 2.8K) Torque the fittings and hoses to the specifications listed in the Torque Chart Section 2.11.

IMPORTANT
Follow the Torque Chart In Section 2.11 when tightening fittings and hoses.

13 Install the access panel with 2 bolts. (Fig. 2.8L)

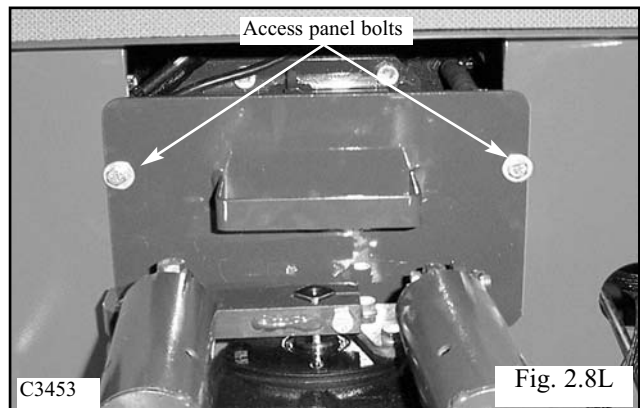
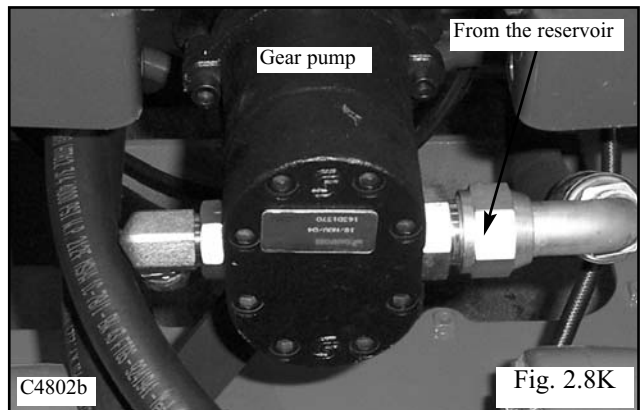
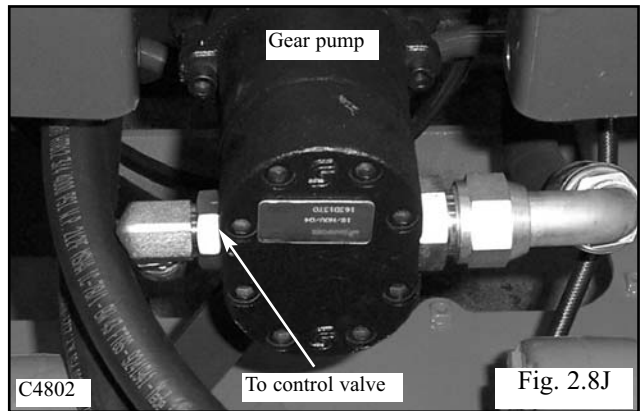
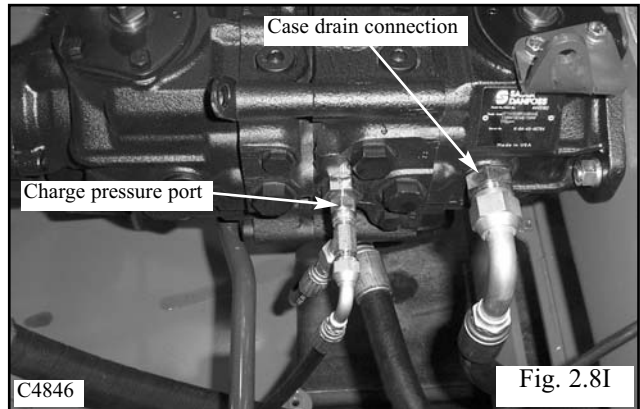

2

TANDEM PUMP REPLACEMENT 2.8

14 Reinstall the steering lever linkage, pintle levers and hydrobacks with mounts. Refer to section 4 for removal and replacement information. (Fig. 2.8M)

IMPORTANT

Follow the start up procedure outlined in section 2.6 upon restarting after pump repairs or replacement.

15 Fill the hydraulic oil reservoir to the proper level.

16 Follow the start up procedure outlined in section 2.6 before attempting to start the loader.

17 The start up must be made with the loader raised securely from the ground. Changing the pumps and the steering control linkages has affected the neutral adjustment. Failure to raise the loader clear of the ground may result in the loader engaging in motion and possibly causing serious injury.



WARNING

This start-up procedure must be made with the loader securely raised off the ground.

18 Start the loader and check for leaks. Make repairs as necessary and replenish the hydraulic oil reservoir (Fig. 2.8N, 2.8O). Never use your hands to check for hydraulic leaks.



WARNING

To prevent personal injury never make repairs to the hydraulic system while the engine is operating.

19 Make adjustments to the steering controls as required. Follow the procedures for control adjustments in Section 4



WARNING

Use caution when dealing with hydraulic fluid under pressure. Escaping fluid under pressure can penetrate the skin and cause serious injury.

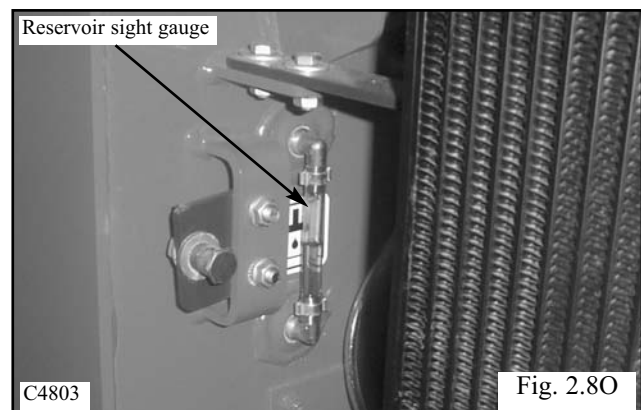
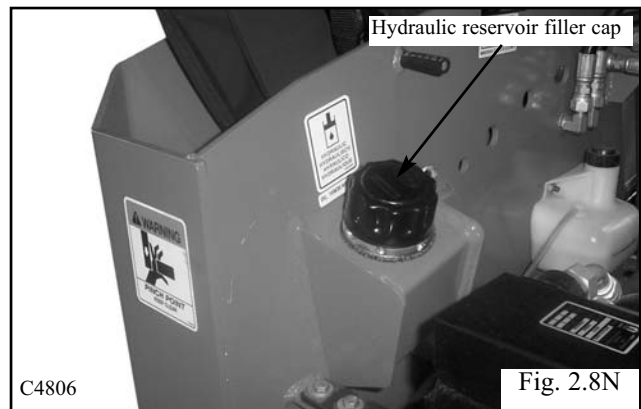
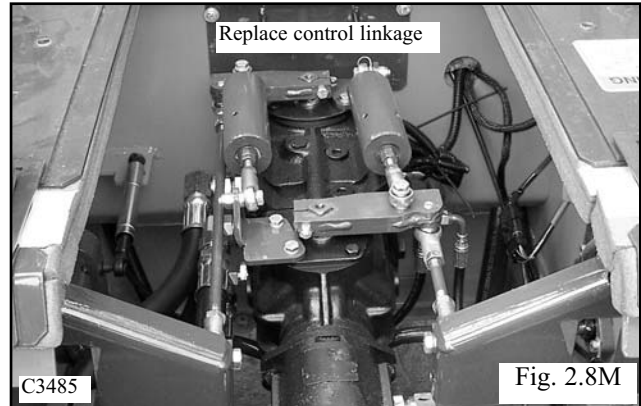

TANDEM PUMP PARTS DIAGRAM 2.9

2

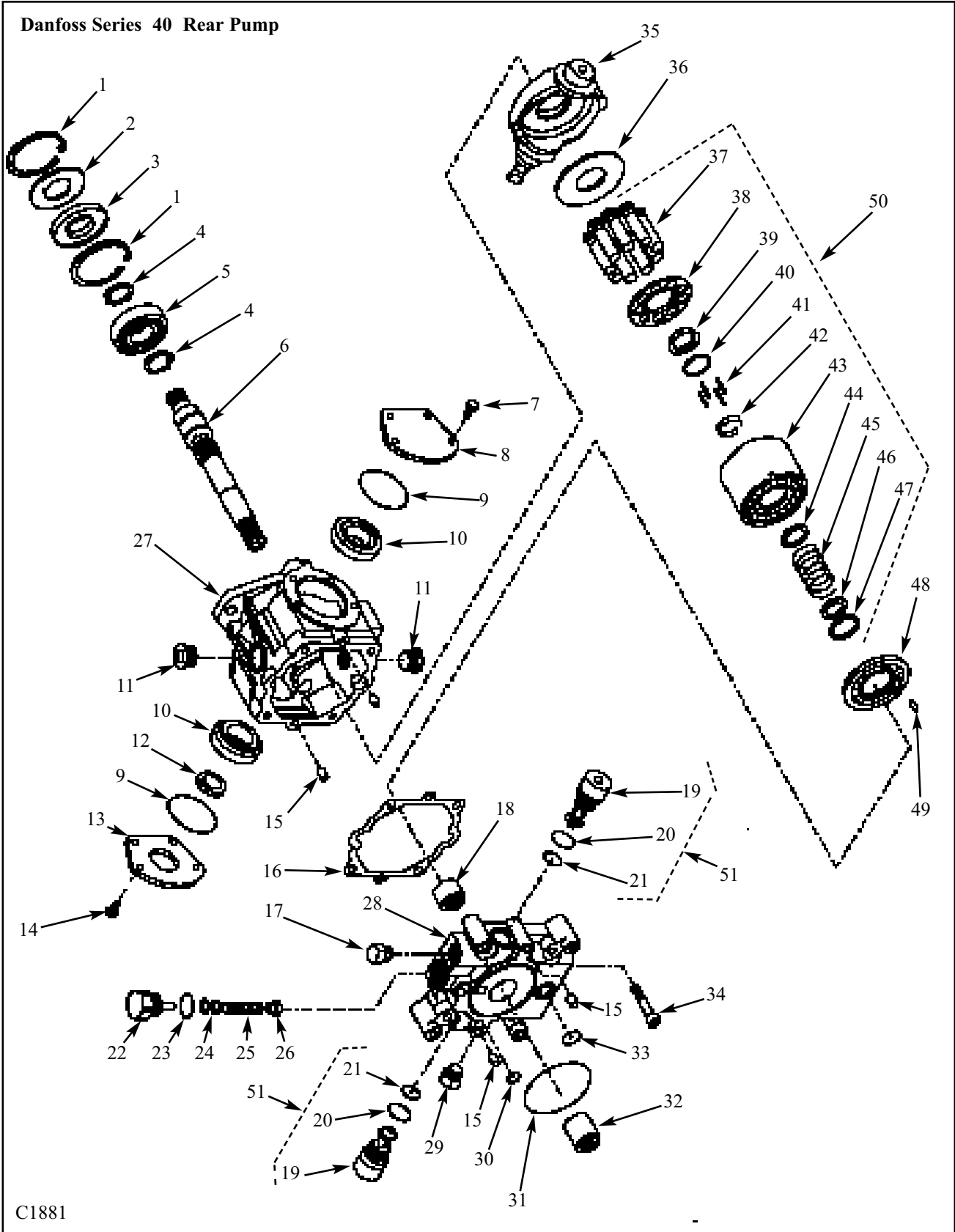

— TANDEM PUMP PARTS DIAGRAM 2.9 —

Rear Pump Diagram C1881 Index

1. Retaining ring
2. Seal support washer
3. Input seal
4. Retaining ring
5. Bearing
6. Drive shaft
7. Bolt
8. Cover
9. O-ring seal
10. Bearing
11. Plug
12. Swashplate seal
13. Swashplate cover
14. Bolt
15. Dowel pin
16. Gasket
17. Plug
18. Bearing
19. Relief valve
20. O-ring seal
21. O-ring seal
22. Charge relief plug
23. O-ring seal
24. Charge relief shims
25. Charge relief spring
26. Charge relief poppet
27. Pump housing
28. End cap
29. Plug
30. O-ring seal
31. O-ring seal
32. Coupler
33. O-ring seal
34. Screw
35. Swashplate
36. Thrust plate
37. Piston assembly
38. Slipper retainer
39. Slipper retainer guide
40. Special washer
41. Slipper hold down pins
42. Hold down pin retainer
43. Cylinder block
44. Washer
45. Spring
46. Washer
47. Retaining ring
48. Valve plate
49. Spring pin
50. Cylinder block kit
51. Relief valve kit

**For further service instructions refer to a Sauer
Danfoss Dealer and request a Service / Repair Manual
#BLN 9992**

2

TANDEM PUMP PARTS DIAGRAM 2.9

2

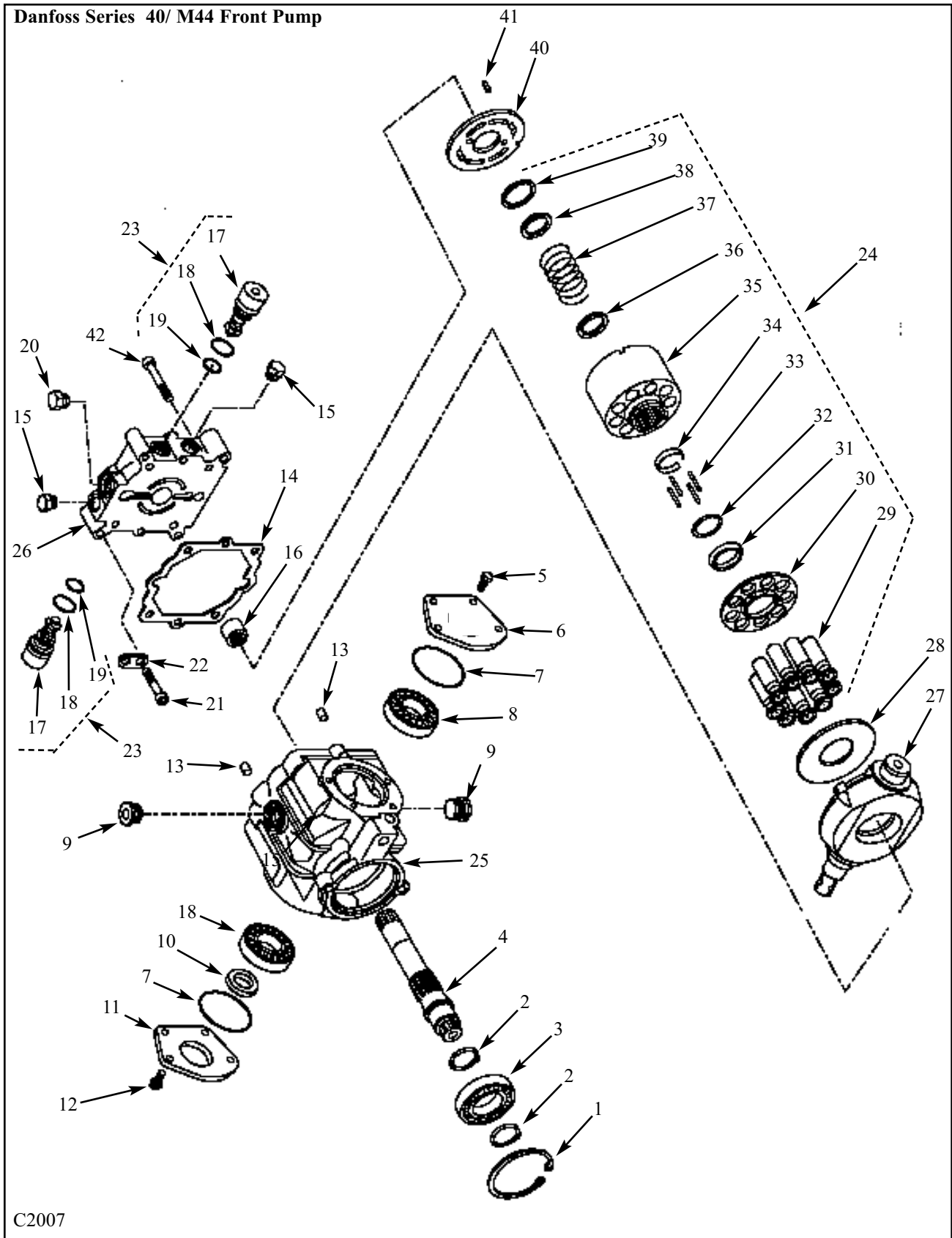

— TANDEM PUMP PARTS DIAGRAM 2.9 —

Front Pump Diagram C2007 Index

- 
1. Retaining ring
 2. Retaining ring
 3. Bearing
 4. Drive shaft
 5. Bolt
 6. Cover
 7. O-ring seal
 8. Bearing
 9. Plug
 10. Swashplate seal
 11. Swashplate cover
 12. Bolt
 13. Dowel pin
 14. Gasket
 15. Plug
 16. Bearing
 17. Relief valve
 18. O-ring seal
 19. O-ring seal
 20. Plug
 21. Screw
 22. Bracket
 23. Relief valve kit
 24. Cylinder block kit
 25. Pump housing
 26. End Cap
 27. Swashplate
 28. Thrust plate
 29. Piston assembly
 30. Slipper retainer
 31. Slipper retainer guide
 32. Special washr
 33. Slipper hold down pins
 34. Hold down pin retainer
 35. Cylinder block
 36. Washer
 37. Spring
 38. Washer
 39. Retaining ring
 40. Valve plate
 41. Sprilng pin

**For further service instructions refer to a Sauer
Danfoss Dealer and request a Service / Repair Manual
#9992**

DRIVE MOTOR 2.10

General Information

2

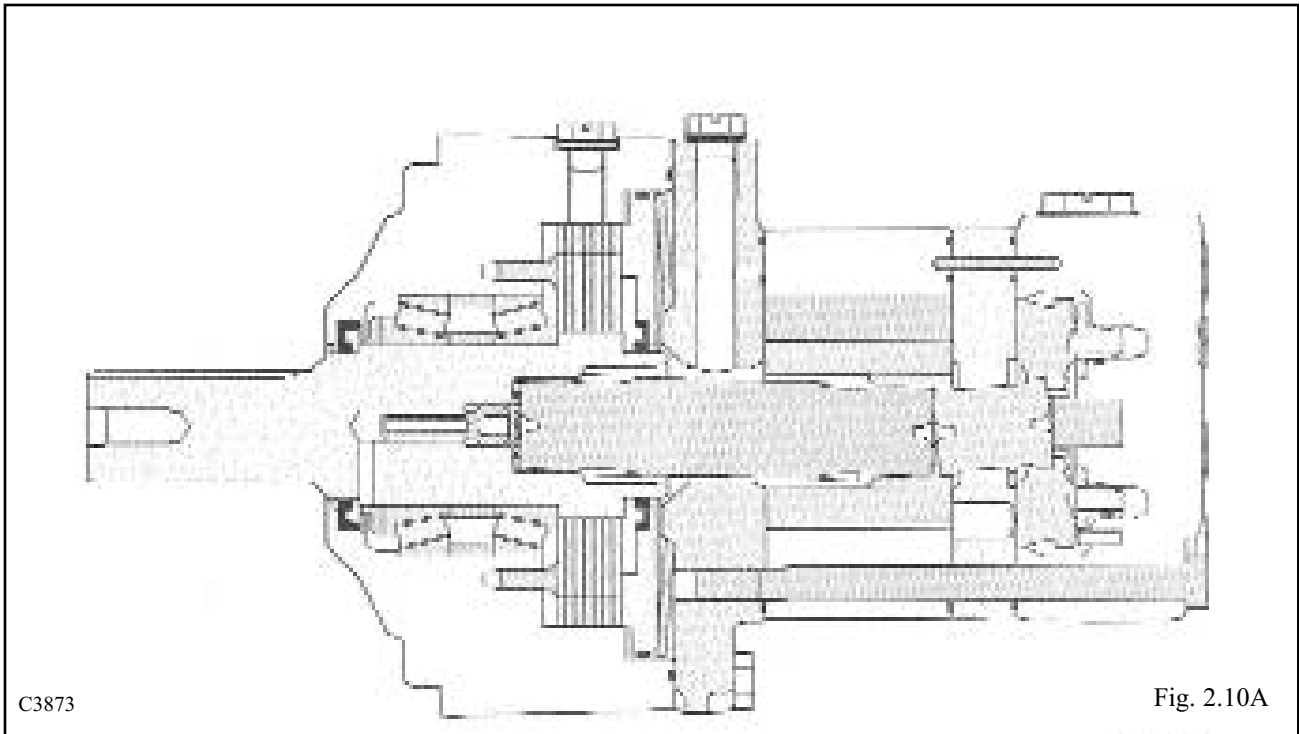

The basic geroter design uses a combination of mechanical and hydraulic principles that are utilized in the high torque, low speed motors.

The outer ring (Fig. 2.10B) of the geroter assembly is similar to an internal gear that is held in a fixed position by securing it to the motor housing. The rotating inner gear, called a star, orbits inside the secured outer ring.

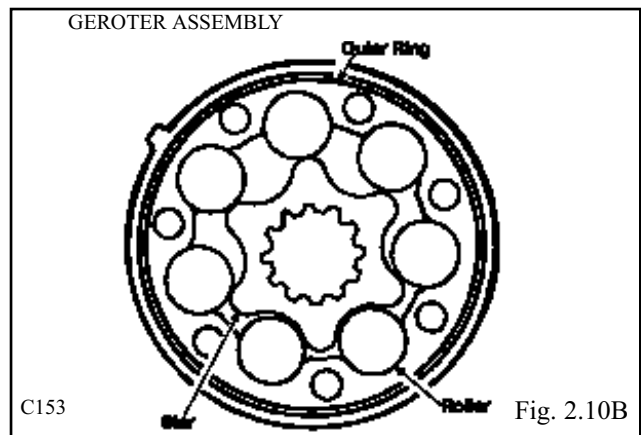

Because of the different number of teeth on the star and outer ring, the star rotates in an eccentric circular orbiting motion from the housing center line. (Fig. 2.10C)

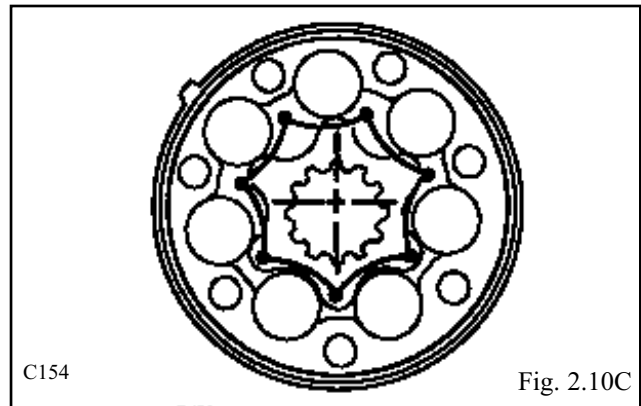

DRIVE MOTOR 2.10

A drive shaft is used to transmit the rotation of the star to the output shaft. The drive shaft has crowned external splines to match the internal splines in the star and output shaft. This type of drive is used because the star center line continuously changes during rotation.

As the star orbits, it causes a continuous opening and closing of the outer ring fluid pockets. Half of these fluid pockets are subject to fluid pressure, causing star rotation, and the opposing half are connected to the return line.

When pressure is introduced into the fluid pockets on the right side of the star (Fig. 2.10D) the output rotation will be counterclockwise. When the fluid pockets on the left side of the star are pressurized the output shaft rotation will be clockwise.

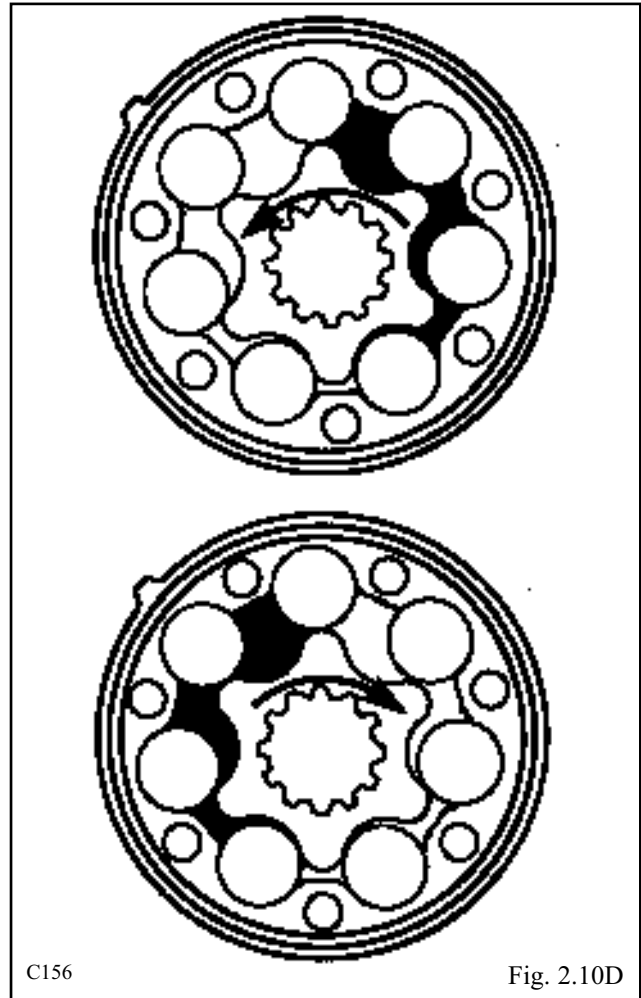

To seal the fluid pockets the torque motor incorporates a rotating roller type seal. (Fig. 2.10E) This type of a rolling seal reduces friction at the star points providing increased efficiency and reduced component wear.

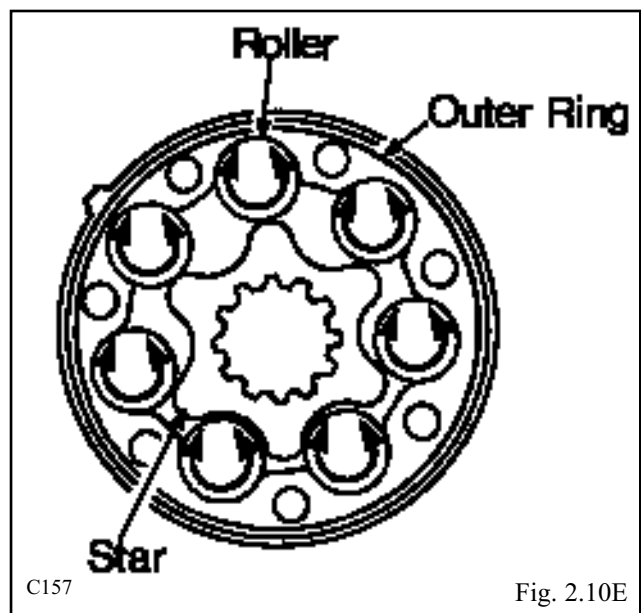

DRIVE MOTOR 2.10

The gerotor (Fig. 2.10F), is both a fluid displacement motor and a gear reducer. It provides 8 times (the number of star points) greater power per revolution than a gear, vane or piston type motor. This means that 8 times the greater torque can be developed at one eighth the speed without further gear reduction.

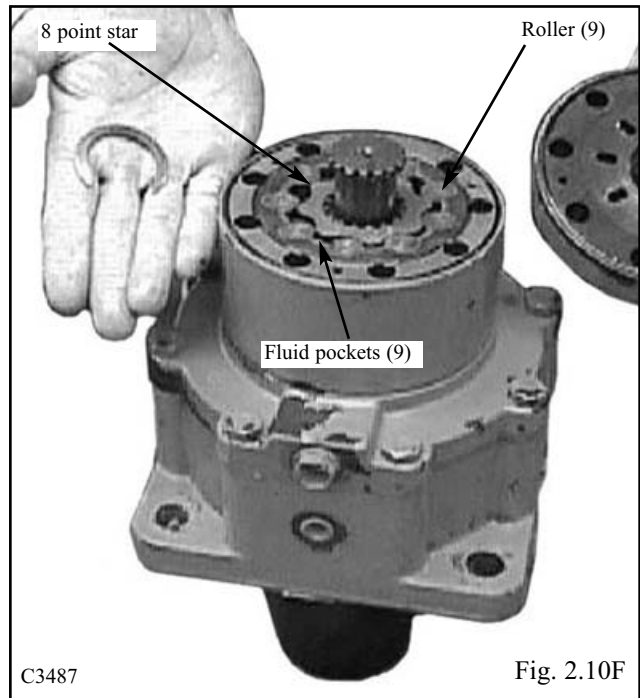

Example shown in Fig. 2.10G is one complete star orbit, or one sixth of the output shaft rotation. The star must travel through 6 complete orbits for each single rotation of the output shaft creating a speed reduction of 6 to 1. The use of 7 fluid power pockets with the 6 to 1 ratio provides 42 fluid power cycles per each complete shaft revolution.

NOTE: Actual star point count is 8. This is only an example.

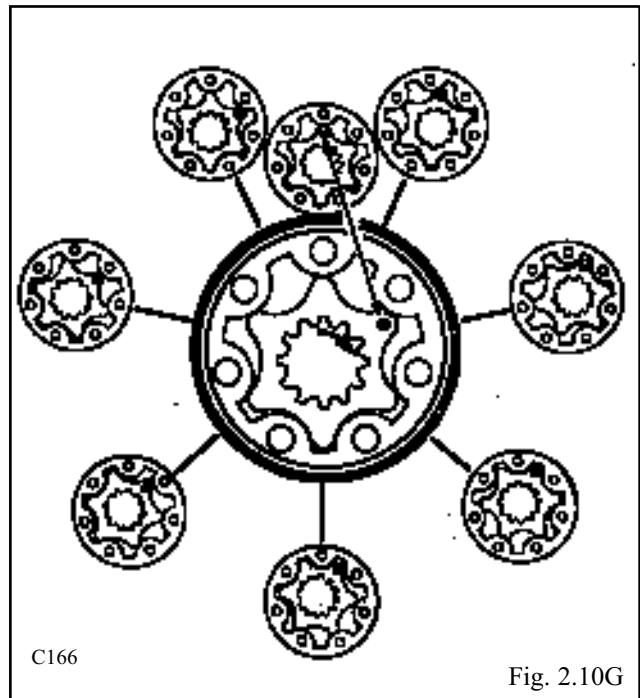

DRIVE MOTOR 2.10

For smooth and continuous motor output rotation, the torque motor utilizes a disc valve which operates in synchronization with the geroler star. The disc valve arrangement consist of a stationary balance plate, rotating disc valve and a stationary valve plate.

The disc valve contains an inlet fluid passage port for each star valley and a return fluid passage point.

A separate crowned driveshaft is used to synchronize the disc valve and the geroler star so that they turn as one. To accept fluid from the disc valve, the valve plate also contains internal porting passages to each outer ring pocket area.

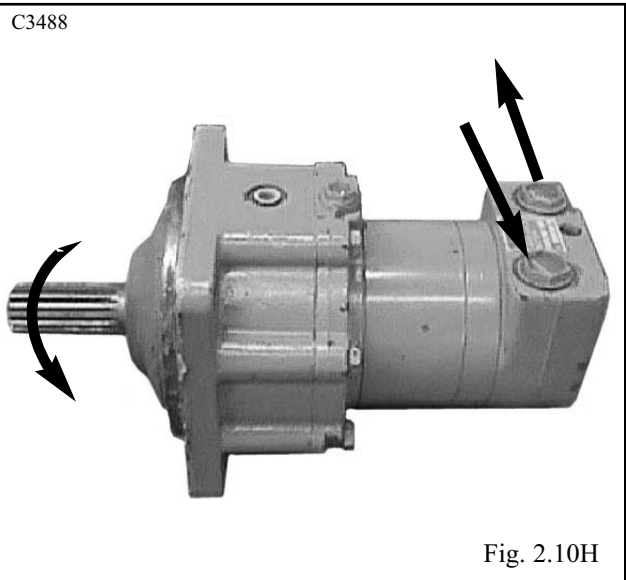

Fig. 2.10H

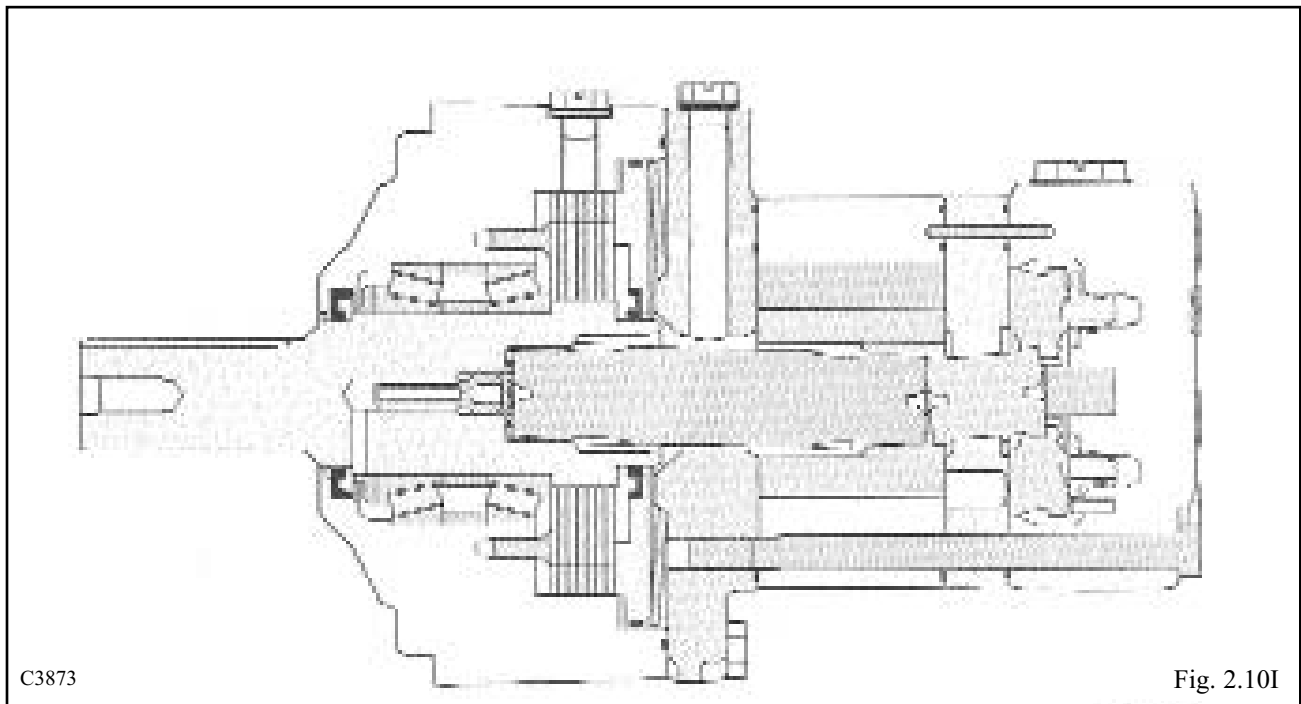

Fig. 2.10I

Fluid enters the housing through the inlet port and is directed to the balance plate. The balance ring contains an inner and outer seal to separate the high and low pressure fluid passages. Fluid passes through the stationary balance plate to the rotating disc valve. The rotating disc valve ports the fluid to the stationary valve plate and the proper side of the geroter pockets causing the rotor star to turn.

As the rotor star rotates, and each fluid pocket reaches its full open position, the return porting in the rotating disc

valve opens to allow the fluid in the pocket area to pass back through the valve plate, disc valve, balance plate and out through the housing return port, as the pocket closes.

The disc valve is timed to the gerotor rotor star to govern the inlet fluid flow to the output shaft rotation. If the timing of the disc valve to the gerotor star is off one tooth, the relationship of input fluid flow to output motor shaft rotation will be reversed.

DRIVE MOTOR 2.10

Removal

- 1 Remove any attachment, raise the boom arms and engage the boom support pins.
- 2 Raise the loader securely off the ground.
- 3 Remove the wheels on the side to be repaired.
- 4 Drain the oil from the final drive housing. Be prepared to contain approximately 17 litres (4.5 gal) of fluid. (Fig. 2.10J)



WARNING

To prevent personal injury do not work under the boom arms without the boom supports engaged.

- 5 Remove the seat and hydrostatic shield.
- 6 Remove the final drive inspection cover located between the axles of the final drive housing. (Fig. 2.110)
- 7 Disconnect the chain as outlined in Section 3.

- 8 Remove the 2 high pressure hoses from the drive motor. (Fig. 2.10L) Cap the open hose ends and fittings to prevent contamination.

IMPORTANT

When making repairs to the hydraulic system, keep the work area and parts clean. Use caps and plugs on all open line and ports.

- 9 Disconnect the 2 brake line hoses and cap the hoses and adapter fittings in the drive motor. (Fig. 2.10M)
- 10 Remove the adapter fittings from the drive motor. Plug the open ports in the drive motor to prevent contamination.

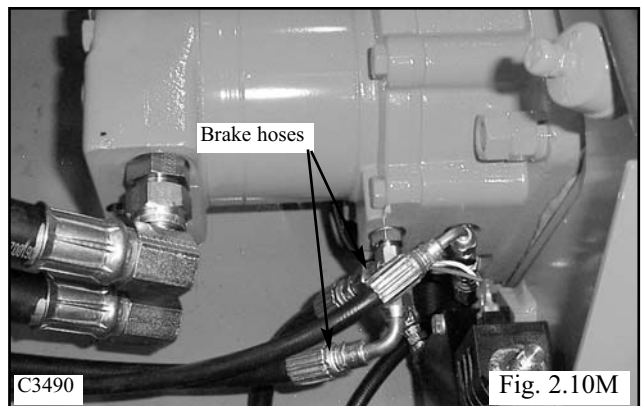
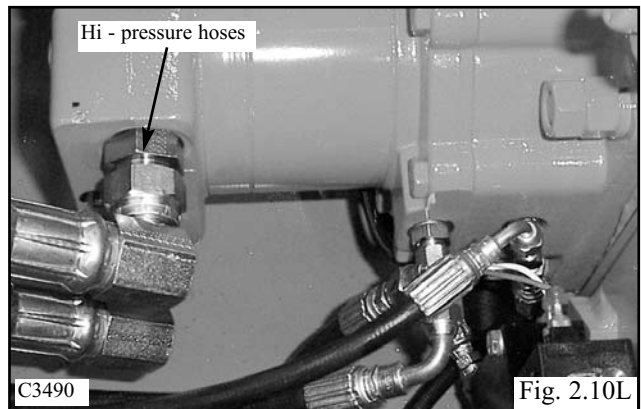
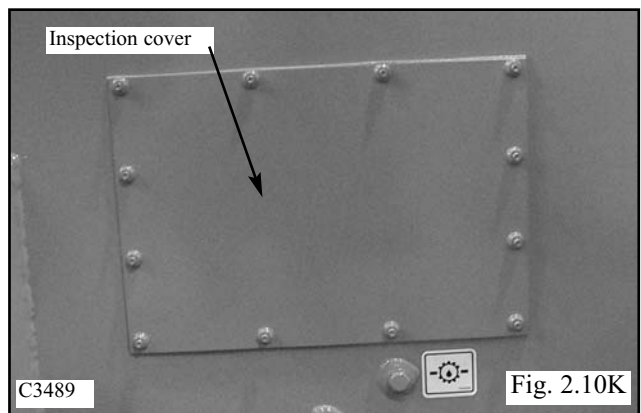
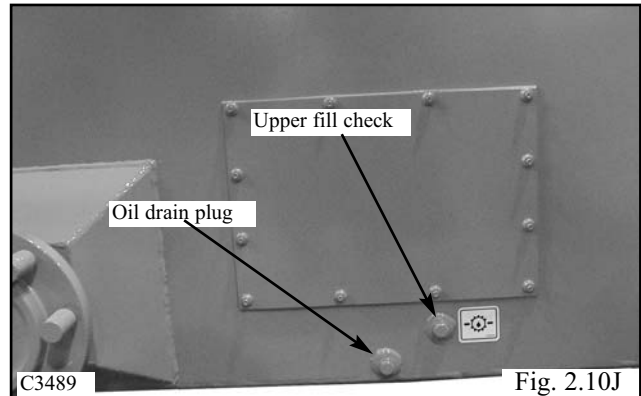

2

DRIVE MOTOR 2.10

Removal

12 Remove the jam nuts, mounting nuts and lock washers from the 4 mounting bolts retaining the drive motor to the final drive housing. (Fig. 2.10N) Hold the head of the bolts from inside the final drive housing. (Fig. 2.10O)

13 Remove the drive motor. Seal the drive motor with silicone upon reassembly.

14 Upon reassembly torque the 4 mounting nuts to 80 ft lbs.

15 If the drive motor replacement is being performed because of major parts failure, such as geroter damage, the hydraulic system must be checked for contamination and flushed if necessary as outlined in Section 2.6.

16 If you are installing a new drive motor, remove the drive motor sprocket and bolt if you wish to reuse the sprocket. (Fig. 2.10P)

17 Install the sprocket, machined washer, lock washer and bolt. Apply Loctite 242 (blue) to the threads of the bolt before torquing (Fig. 2.10Q) and torque the bolt to 40 ft lbs. (54 Nm).

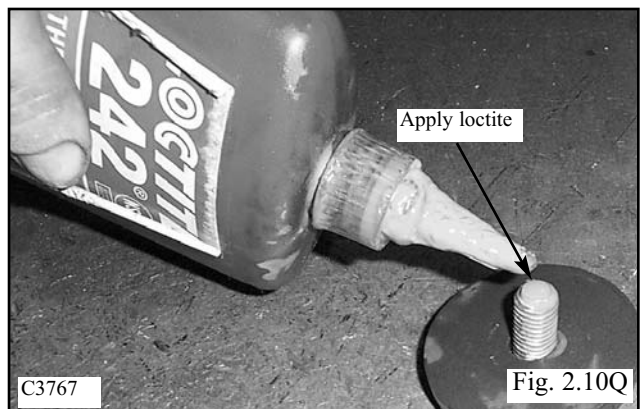
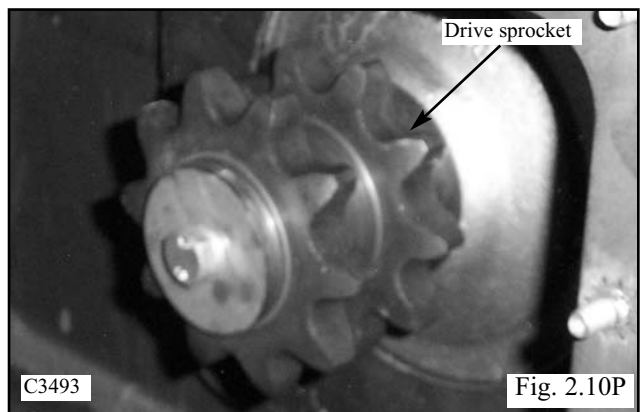
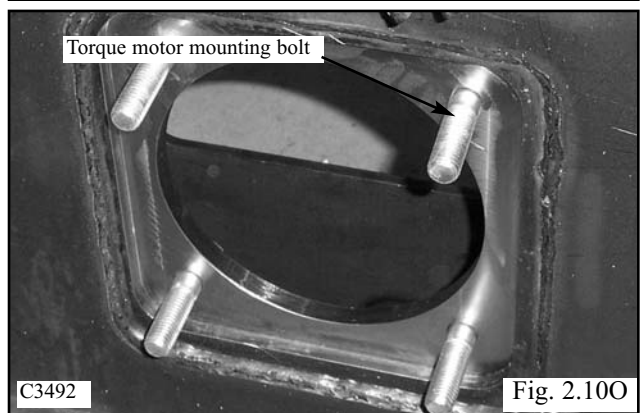
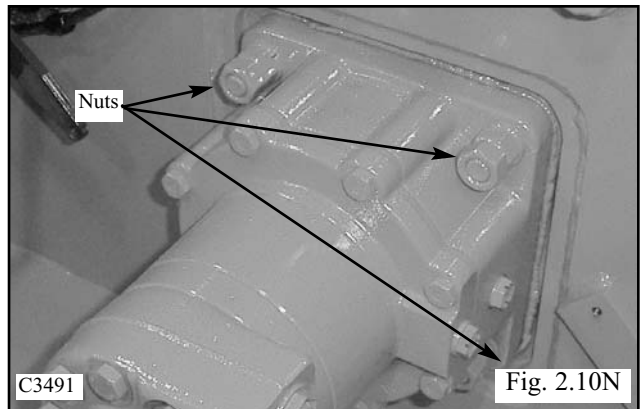

DRIVE MOTOR 2.10

Replacement

1 Clean the mounting areas thoroughly that need to be sealed with silicone. (Fig. 2.10R, 2.10S)

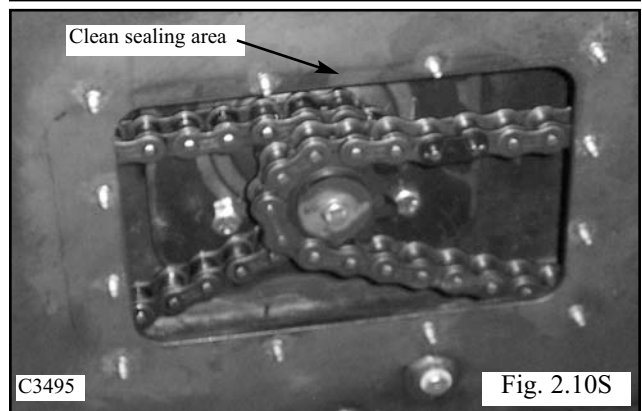
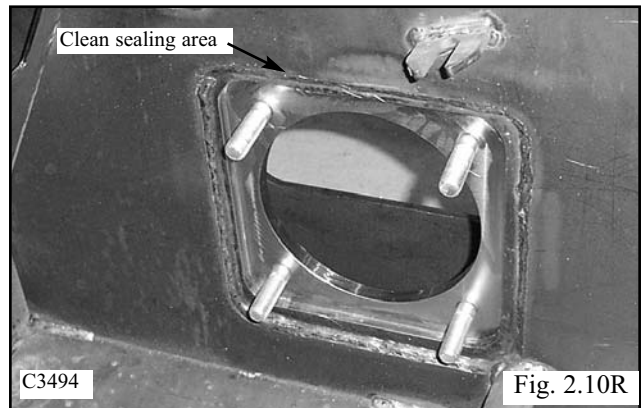

2 Apply a bead 1/4 of an inch thick around the drive motor bearing retainer and around each mounting hole. (fig. 2.10T)

3 Install the drive motor and sprocket assembly to the final drive housing.

4 Install the 4 bolts, lockwashers and mounting nuts and torque to 80 ft lbs. (115 Nm.)

5 Install the 4 jam nuts. Torque the jam nuts to 40 ~ 60 ft lbs. (54 ~ 81 Nm.)

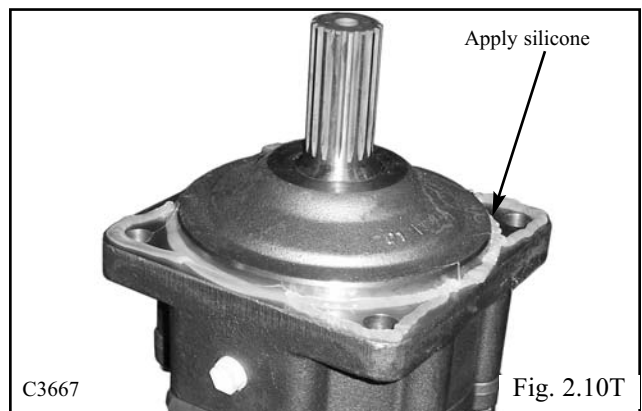

6 Replace the master link in the drive chain. Section 3. shows chain replacement procedure.

7 Add oil to the final drive housing until it trickles out the upper check plug hole. This will require approximately 4.5 gal (17 litres) of 10w30 API SJ (Fig. 2.10U)

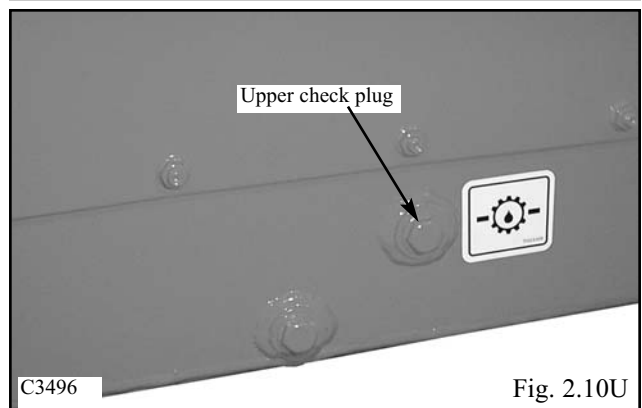

2

DRIVE MOTOR 2.10

IMPORTANT

Refer to the torque chart in Section 2.11 when tightening hydraulic hoses and fittings

IMPORTANT

Inspect fitting o-rings and flares for marks or damage. Replace if necessary.

- 8 Install the adapter fittings to the drive motor.
- 9 Install the brake lines to the drive motor. (fig. C3490)



WARNING

Use caution when dealing with hydraulic fluid under pressure. Escaping fluid under pressure can penetrate the skin and cause serious injury.

- 10 Install the high pressure drive hoses. (Fig. 2.10W)
- 11 Clean the final drive housing and inspection cover thoroughly before sealing. (Fig. 2.10V)
- 12 Install the inspection cover. When installing the nuts, do not over tighten. The mounting torque should not exceed 15 ft lbs. (20 Nm)
- 14 Start the engine and check for hydraulic leaks. Do not use your hands to trace hydraulic leaks. Shut off the engine and inspect each fitting for proper torque.



WARNING

To prevent personal injury never make repairs to the hydraulic system while the engine is operating.

- 15 Install the wheels and torque the nuts at 100 to 110 ft lbs. (136 to 149 Nm.) (Fig. 2.10Y)
- 16 Install shields and seat, let loader down to ground and test drive to check performance.

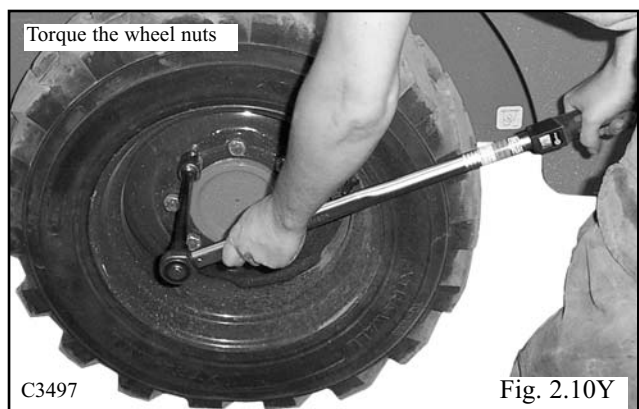
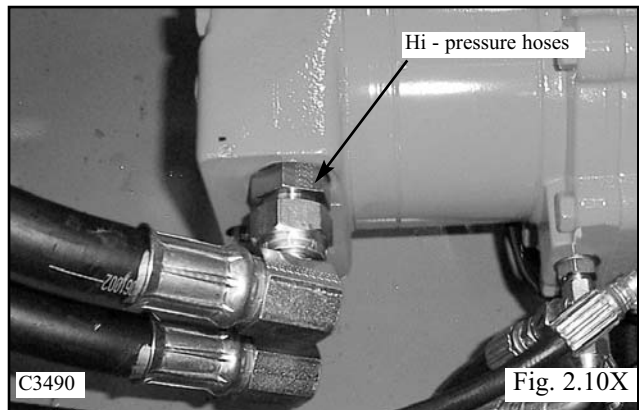
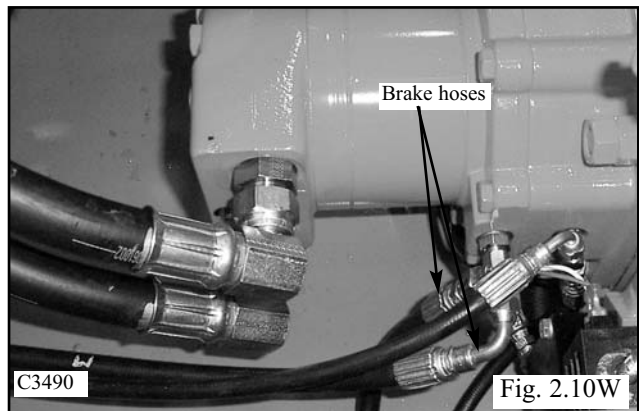
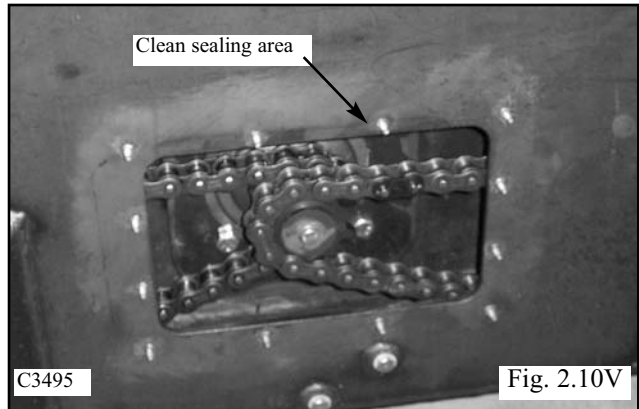

DRIVE MOTOR 2.11

Parts Illustration

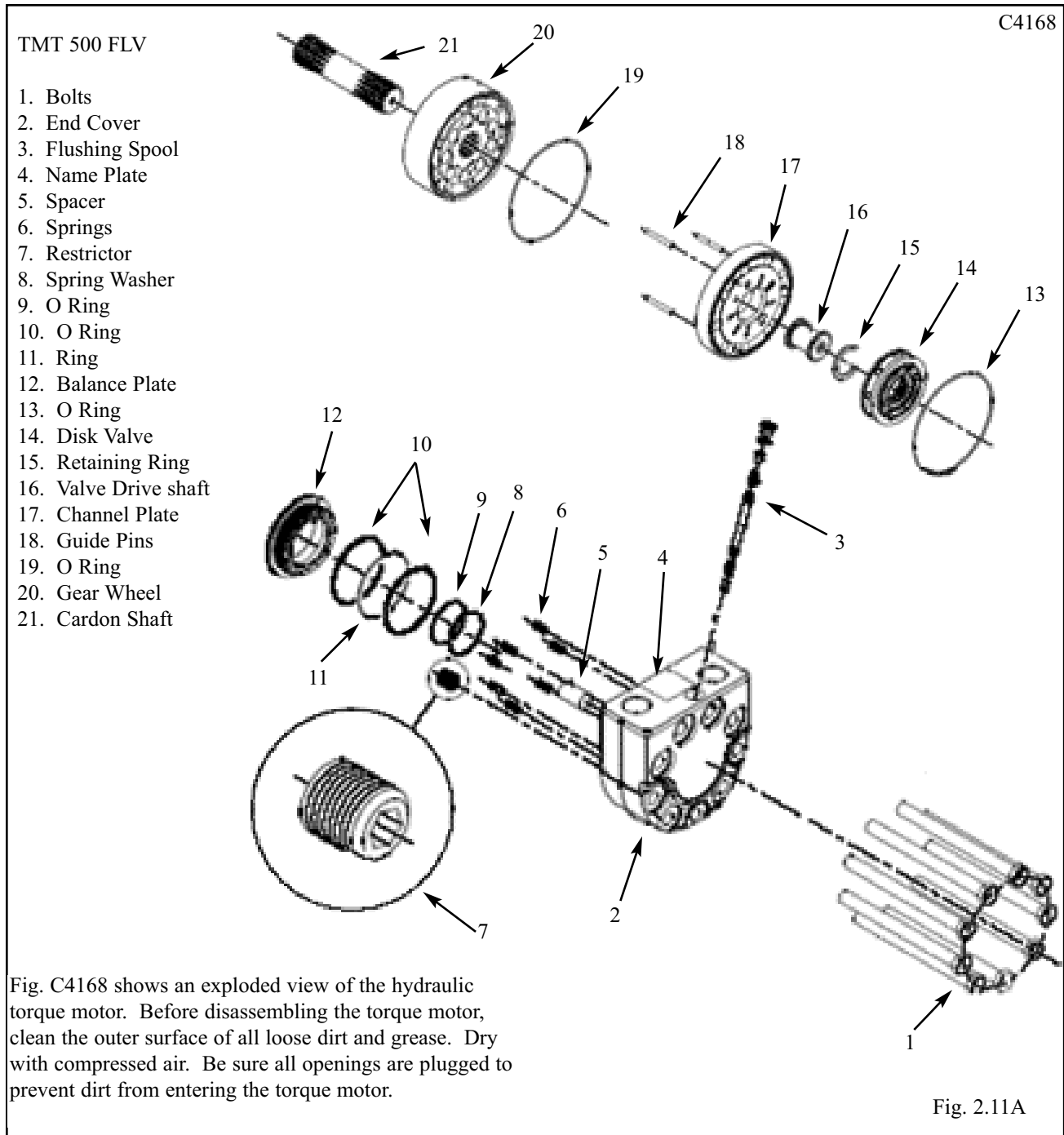

WARNING

To avoid eye injury, use safety goggles when cleaning with compressed air.

IMPORTANT

When making repairs to the hydraulic system, keep the work area and parts clean. Use caps and plugs on all open line and ports.

DRIVE MOTOR 2.11

Parts Illustration

2

TMT 500 FLV

C4169

1. Screws
2. O Ring
3. Bearing Housing
4. Spring Plate
5. Piston
6. O Ring
7. Spacer Disc
8. Shaft Bearing Retainer
9. Screws
10. Outer Brake Disc
11. Inner Brake Disc
12. Screw
13. Bearing
14. Splined shaft
15. O ring
16. Screws
17. Retaining ring
18. Shaft Seal
19. Bearing Housing

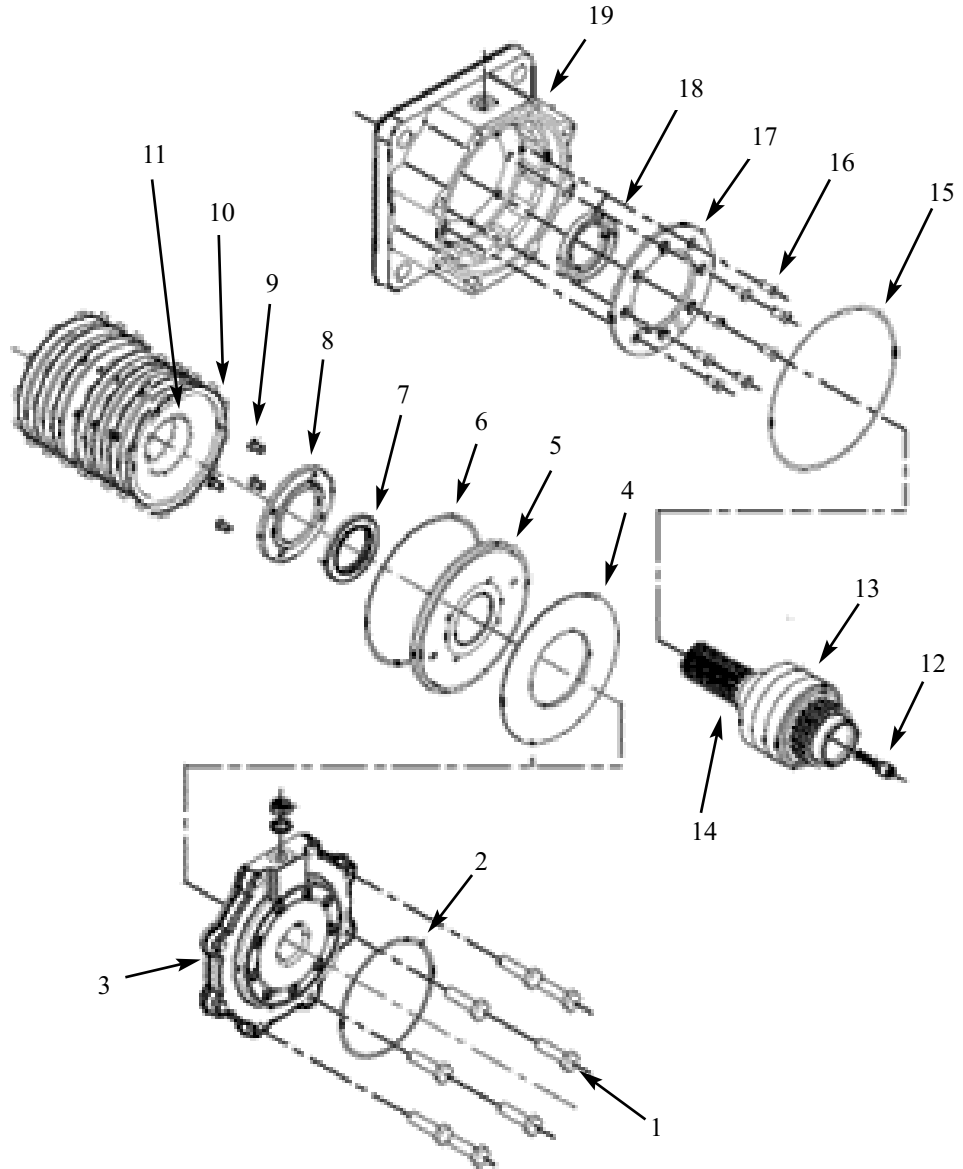

Fig. 2.11B



WARNING

To avoid eye injury, use safety goggles when cleaning with compressed air.

IMPORTANT

When making repairs to the hydraulic system, keep the work area and parts clean. Use caps and plugs on all open line and ports.

DRIVE MOTOR 2.11

Disassembly

1 Stand unit on end and use a collar or vice to support shaft. (Fig. 2.11C)

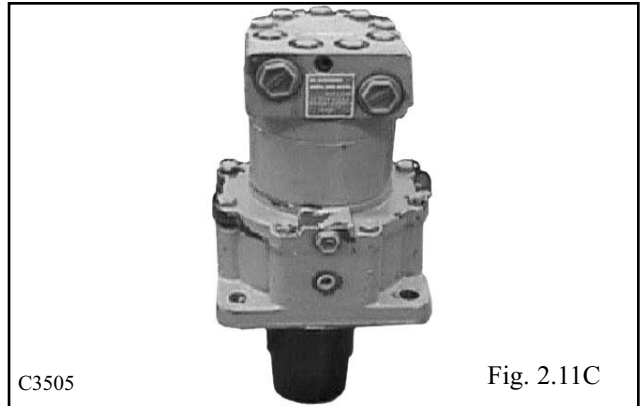

2 Alternate the removal of each bolt (9) as the balance plate will un-spring when the final bolt is removed. (Fig. 2.11D)

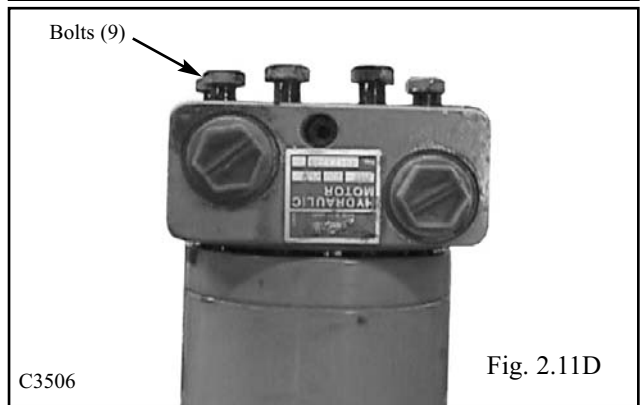

3 Lift off the end cover and note that the spacer may still be in the balance plate or on top of the drive shaft. (Fig. 2.11 E)

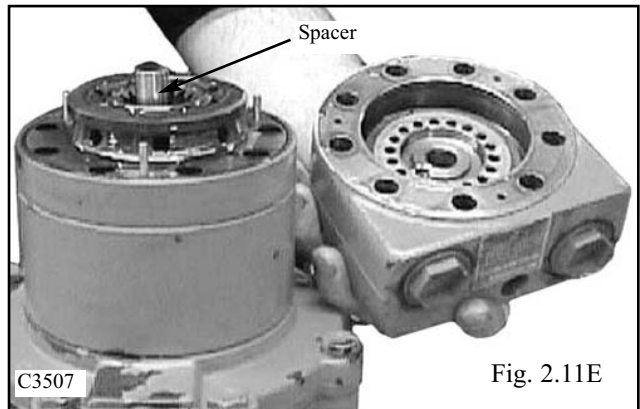

4 On a metal surface, hit the valve housing on the side to release the balance plate and springs. (Fig. 2.11F)

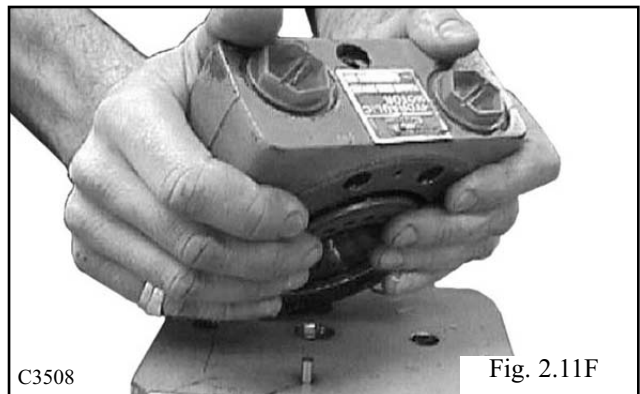

2

DRIVE MOTOR 2.11

Disassembly (cont'd)

2

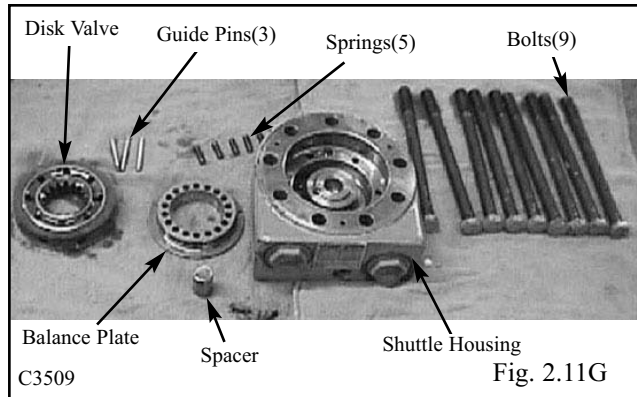

5 Use a 6mm Allen key to remove the flushing valve plug. (Fig. 2.11H)

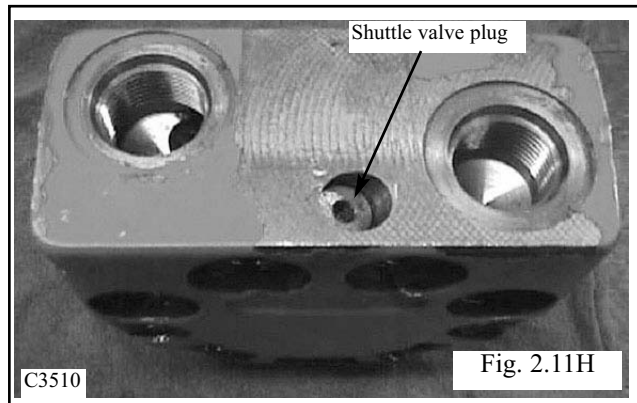

6 Below the plug, the spring guide and the spring are easily removed. (Fig. 2.11I)

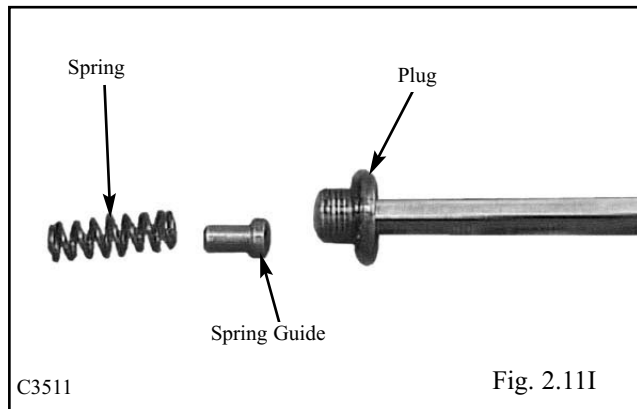

7 The flushing spool is deep within the housing and is very difficult to remove with a magnet. A pair of long thin pliers works much better. (Fig. 2.11J)

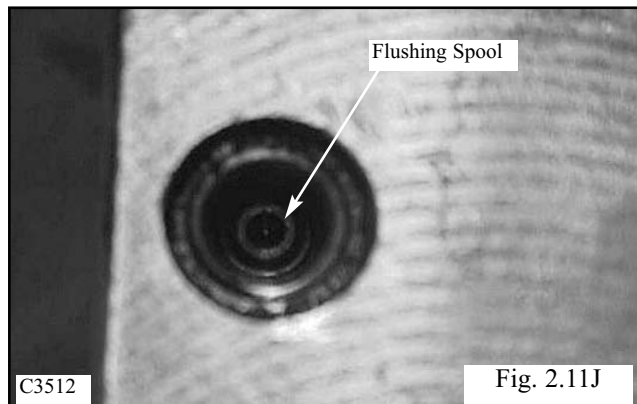

DRIVE MOTOR 2.11

Disassembly (cont'd)

8 Carefully remove spool from the housing to avoid scoring. (Fig. 2.11K)

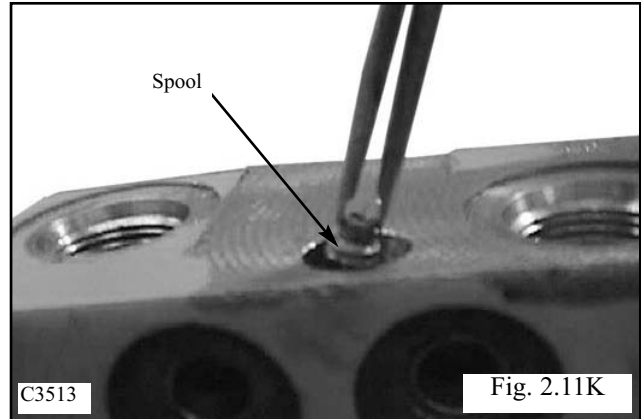

9 Remember that the spool is set at an angle within the housing. (Fig. 2.11L)

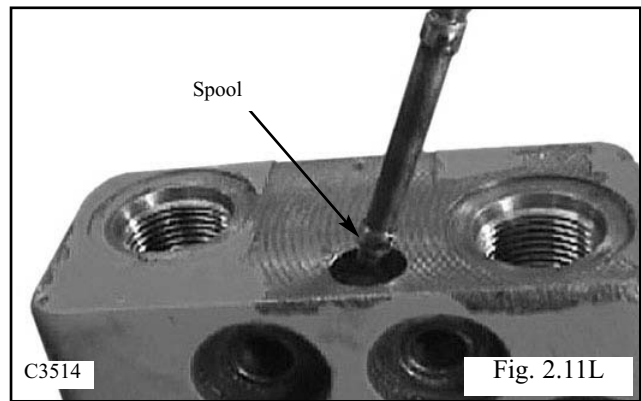

10 The second spring is deep within the housing. It is not necessary to remove this spring unless it is suspected of failure. (Fig. 2.11M)

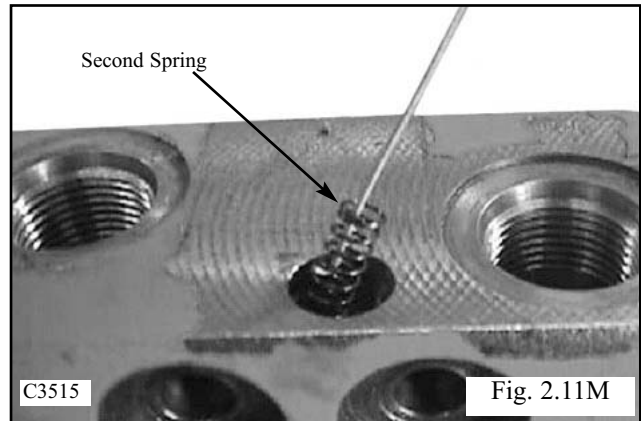

11 The complete flushing valve assembly. Carefully examine prior to reinstalling into housing. (Fig. 2.11N)

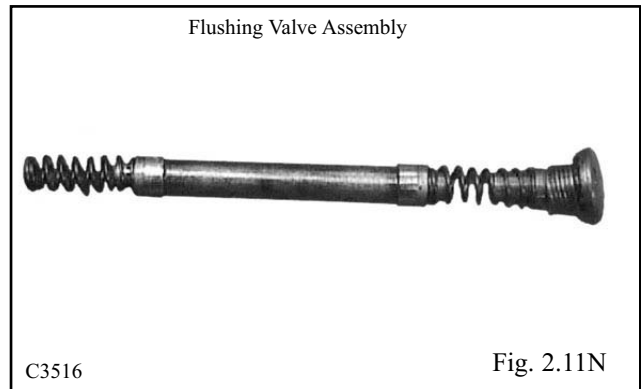

2

DRIVE MOTOR 2.11

Disassembly (cont'd)

2

12 Remove the retaining ring, then the channel plate, and then lift off the drive shaft which will then expose the gearwheel and the Cardon shaft. (Fig. 2.11P)

13 With the drive section removed, loosen the eight (8) brake cover screws and lift off the housing to expose the "spring" plate. (Fig. 2.11Q, 2.11R)

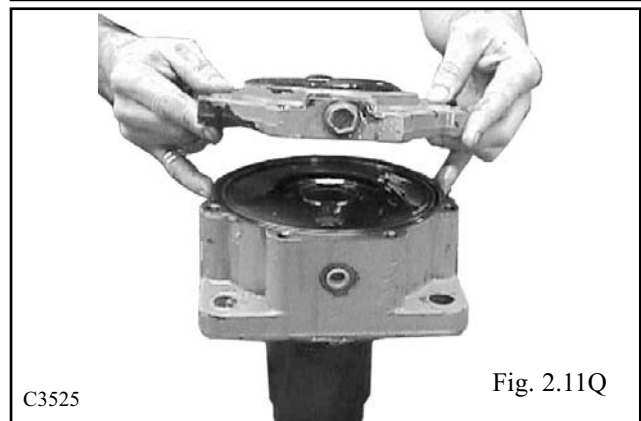
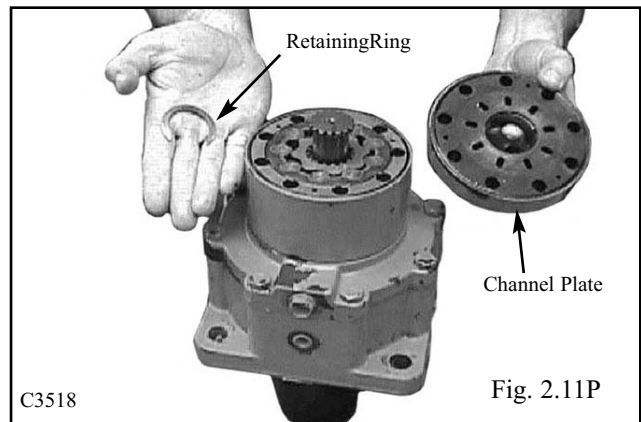
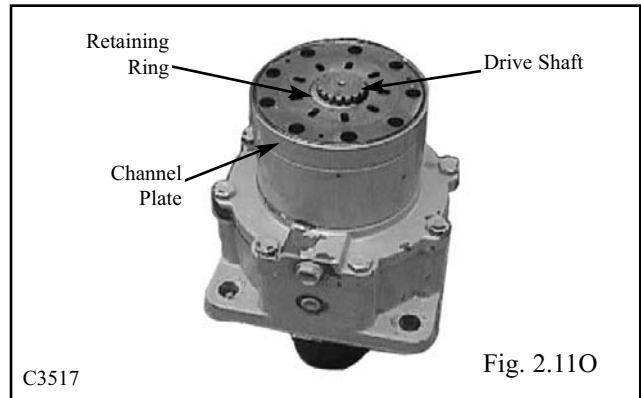

DRIVE MOTOR 2.11

Disassembly (cont'd)

14 With the piston removed, the unit can be turned upside-down to remove the excess oil and the brake disks (inner and outer). (Fig. 2.11S)

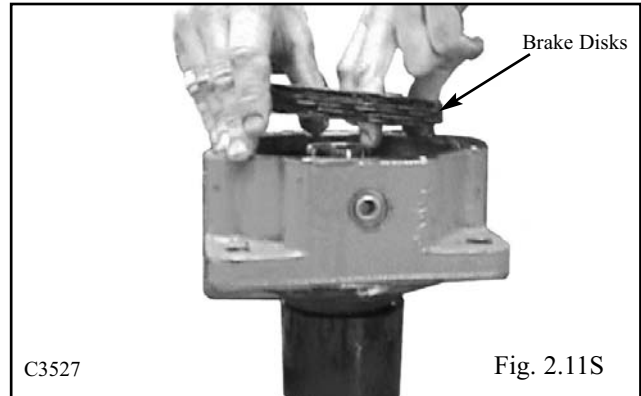

15 With the brake disks removed it exposes the shaft bearing retainer. Remove the eight (8) screws with a Torx driver. (Fig. 2.11T)

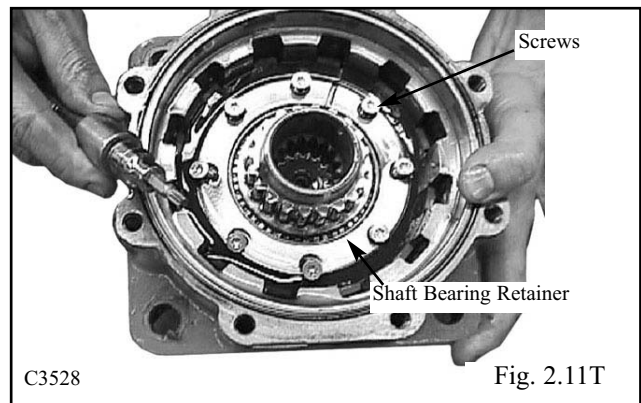

16 Turn the bearing housing and shaft upside-down and hammer out the output shaft. (Fig. 2.11U)

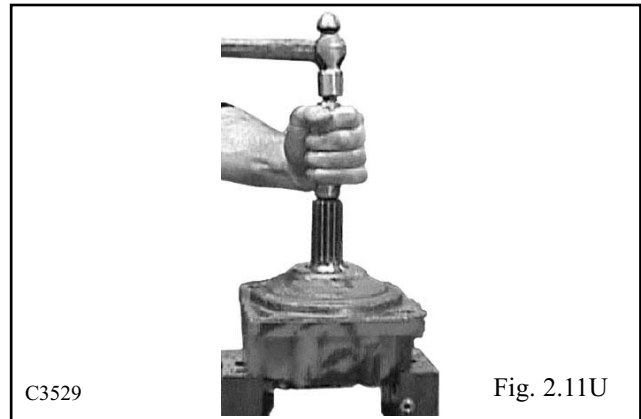

17 At this point the shaft should drop straight downwards. The shaft seal can now be removed and replaced. It can not be removed in any other way. (Fig. 2.11V)

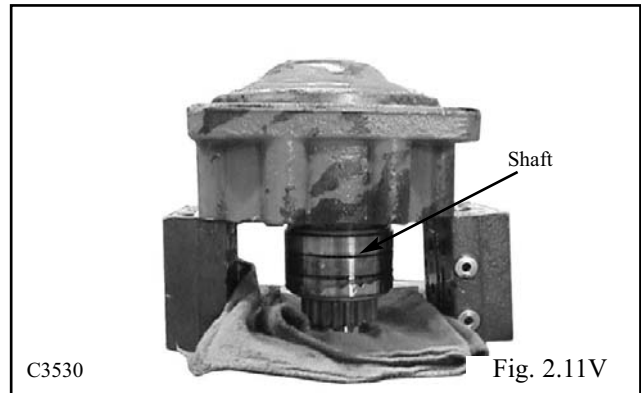

2

DRIVE MOTOR 2.11

Disassembly (cont'd)

18 Complete disassembled unit. (Fig. 2.11W)

2

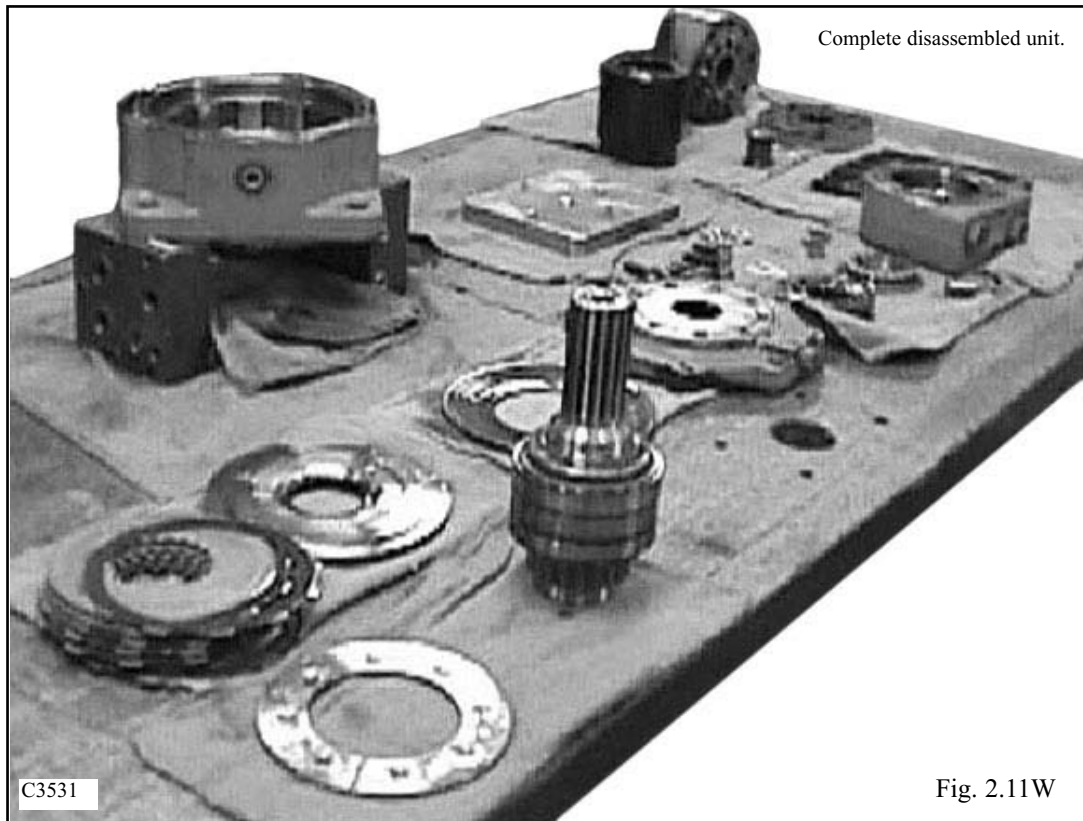

DRIVE MOTOR 2.11

Assembly

1 The re-assembly of the motor is done opposite of the disassembly. Support the housing and install the output shaft and bearing assembly. (Fig. 2.11X).

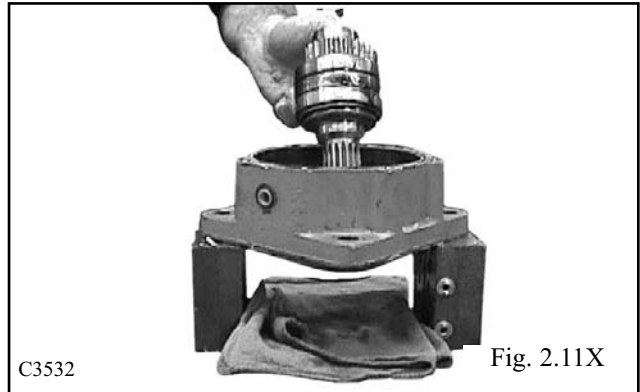

2 Install bearing retaining ring and tighten with Torx drive to 7ft lbs. (Fig. 2.11Y)

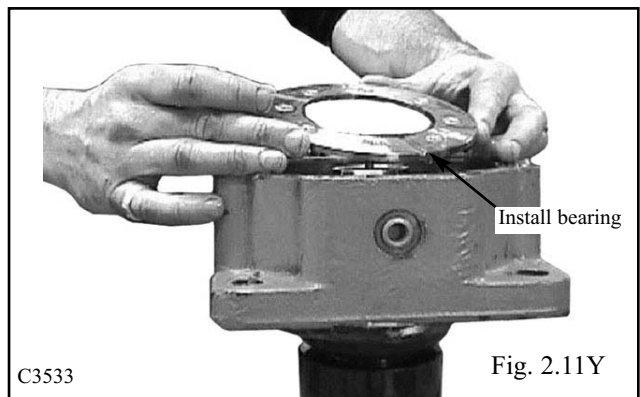

3 Alternate installation of brake disks, first putting in the outer disk (golden color) and then the inner disk (silver color). (Fig. 2.11Z)

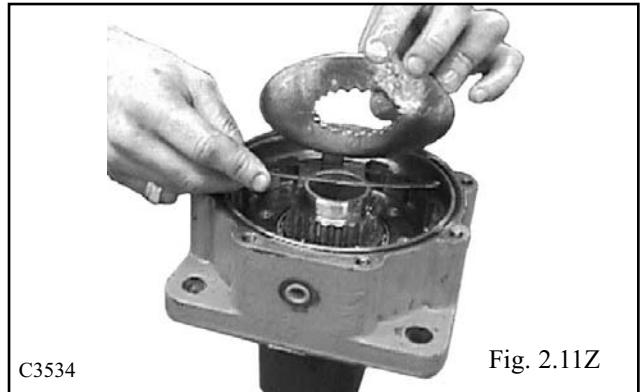

4 Install the piston after all of the disks have been inserted. There will be air trapped, but this will escape when the spring and cover are installed. (Fig. 2.11AA)

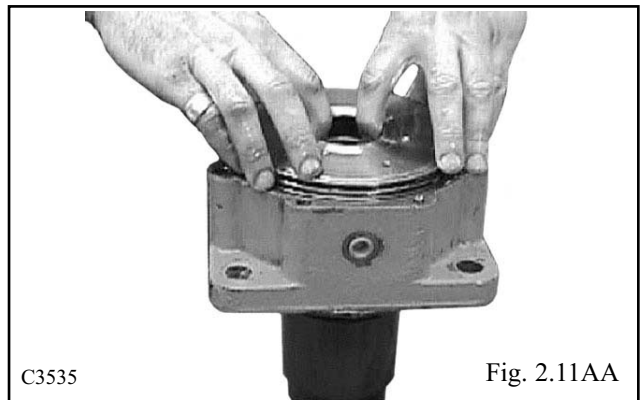

2

DRIVE MOTOR 2.11

5 Install spring plate (Fig. 2.11BB)

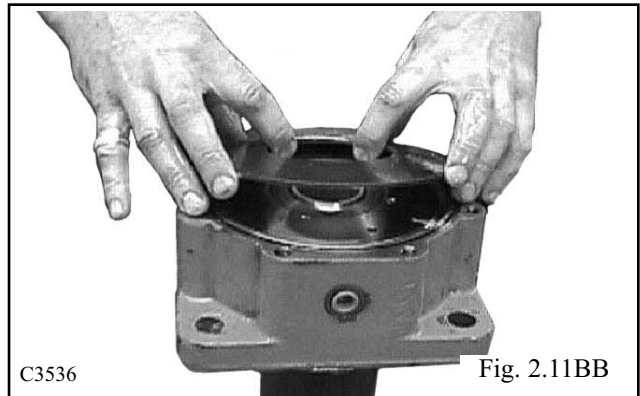

6 Install brake cover and cross tighten all screws to final torque specification of 65 ft lbs. (Fig. 2.11CC)

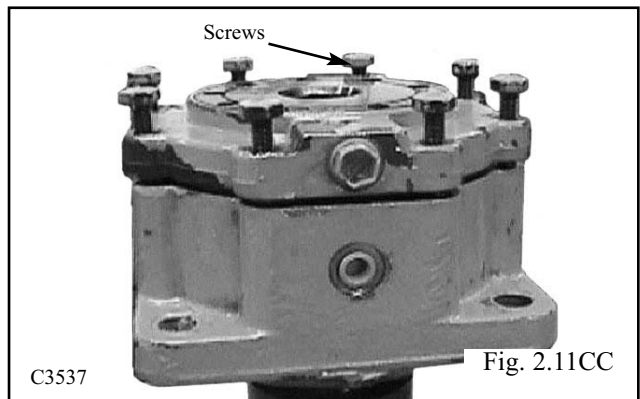

7 Install Cardon shaft and gearwheel. (Fig. 2.11DD)

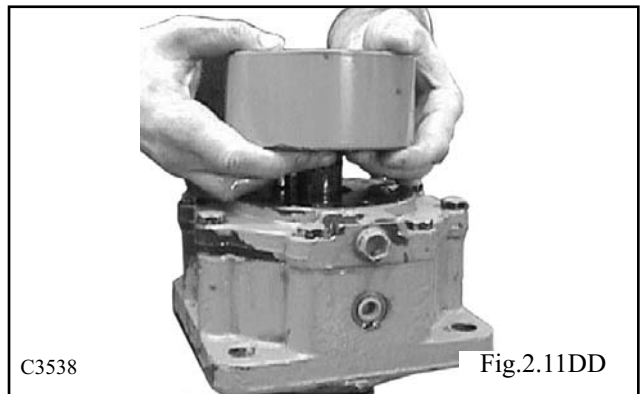

8 With the gearwheel mounted and the carbon shaft in place, place the drive gear valley to valley with the gearwheel. Mount the channel plate (ensuring the drain holes are aligned) and then the valve drive at 15° counter clockwise (one tooth). Then mount the valve housing and re-install the bolts. (Fig. 2.11EE). Incorrect timing will result in the motor operating in reverse.

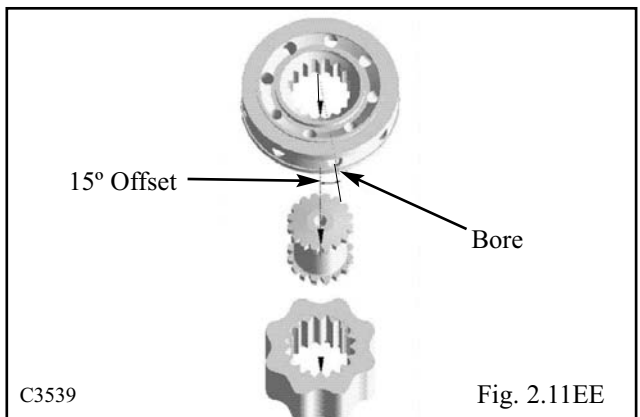

DRIVE MOTOR 2.11

Assembly

9 Gear-roller stage of motor.

Timing is important to ensure oil pressure/flow enters the correct chamber for proper drive/rotation. (Fig. 2.11FF)

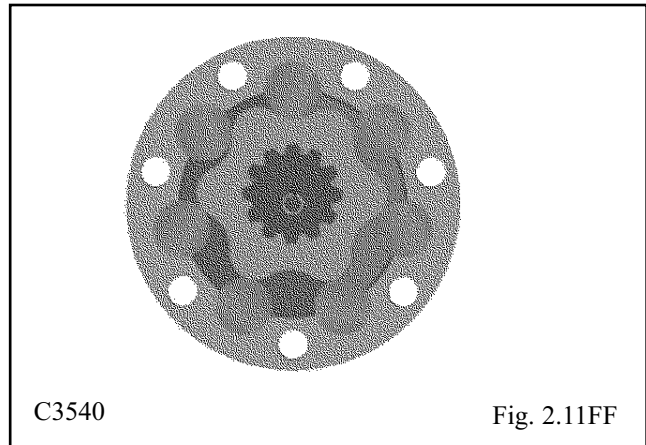

10 When preparing for timing, mark valley to valley in any location on shaft as shown (Fig. 2.11GG).

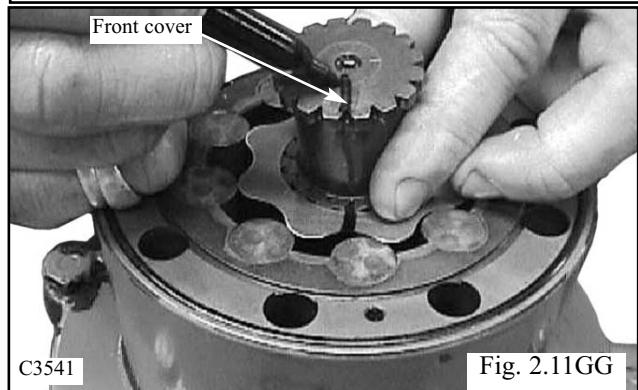

11 Install guide pins on gearwheel (3) and fix channel plate onto gearwheel (Fig. 2.11HH)

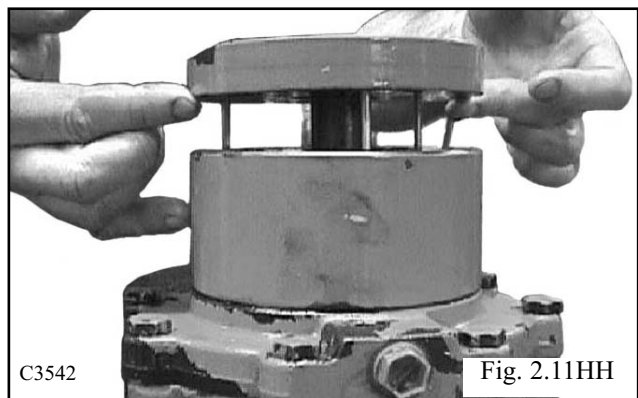

12 Use securing ring and install onto groove on channel plate (Fig. 2.11II).

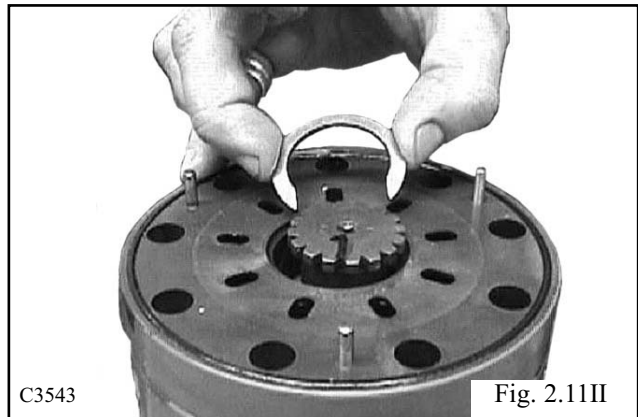

IMPORTANT

NOTE: The fibre plates are also called outer plates due to the “teeth” outside of the plate.

DRIVE MOTOR 2.11

2

13 The timing is critical as the gearwheel valley cannot be seen. Use a marker point as a guide to offset 1 tooth counter-clockwise to the disk valve (Fig. 2.11JJ).

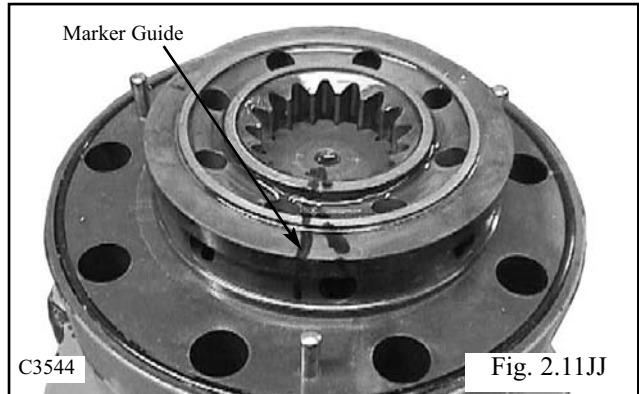

14 In the valve housing, install the 6 springs in the drilled holes (Fig. 2.11KK).

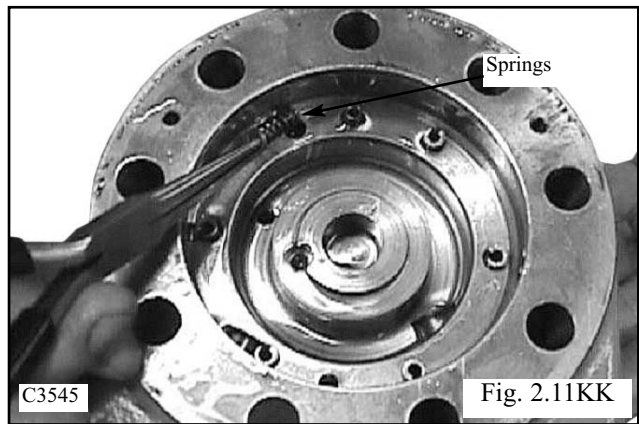

15 Inspect the O-ring seals, and if needed, replace. Install the balance plate and use guide pin for alignment (Fig. 2.11LL).

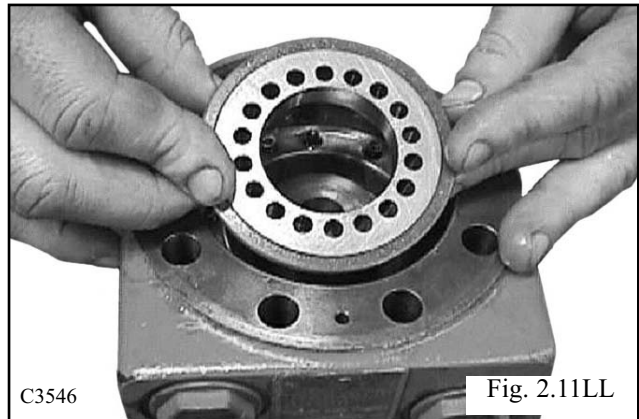

16 Example of an incorrectly installed balance plate. The guide pin becomes damaged and the balance plate is not locked into position. This can cause it to spin and render the motor non-functional (Fig. 2.11MM).

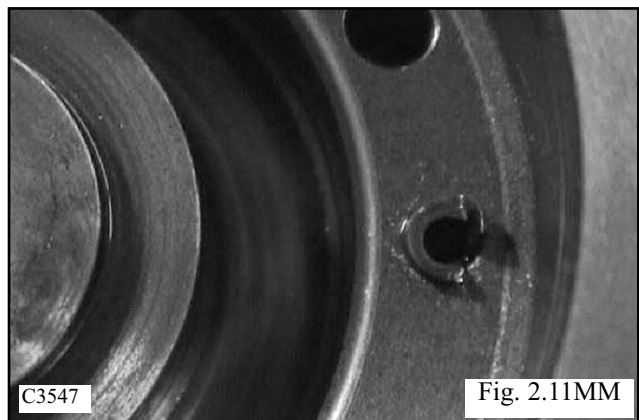

DRIVE MOTOR 2.11

17 With a balance plate incorrectly installed other problems such as a break in the valve housing may occur and damage other hydraulic components (Fig. 2.11NN).

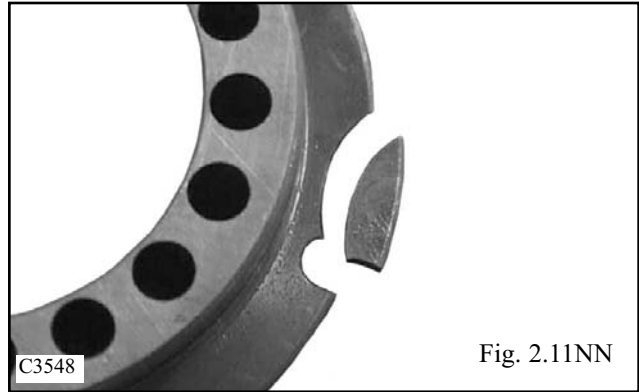

18 With the balance plate in the proper position and tapped down to seat, apply some vaseline or grease to prevent the spacer from falling out when installed onto the motor (Fig. 2.11OO).

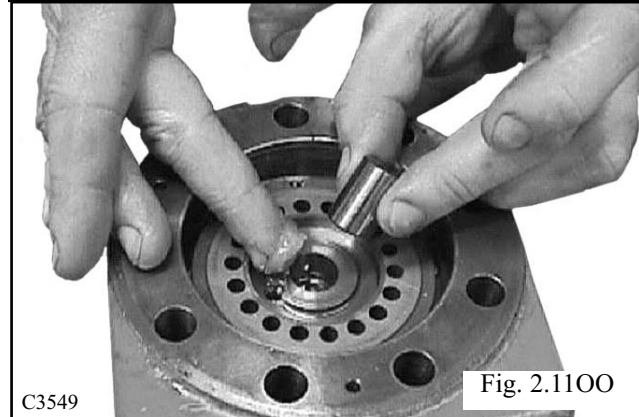

19 Since the motor has been disassembled, the guide pins will locate ports in the offset position. To align with the drain and brake ports, turn the section until correct port alignment is made (Fig. 2.11PP).

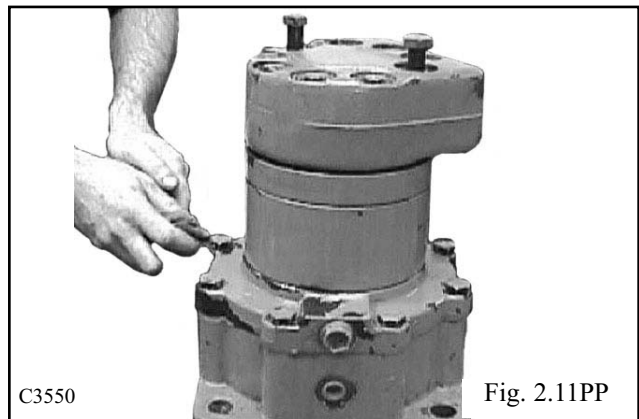

20 With ports all aligned, install balance of screws and tighten in a cross pattern, then final torque all bolts to 81 ft lbs (Fig. 2.11QQ).

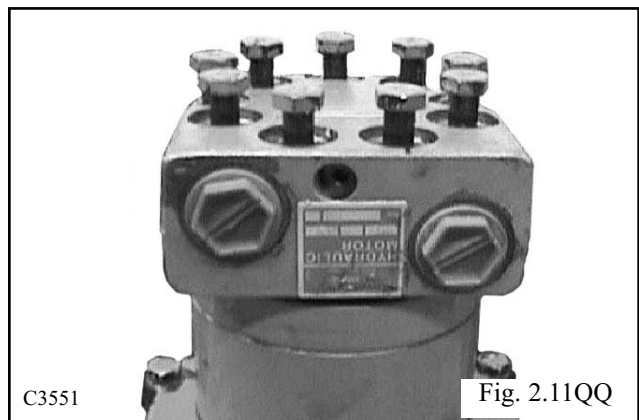

TORQUE CHART 2.12

NOTE: all torque specifications are in ft lbs. (Multiply by 1.36 = Nm)

Hydraulic Fittings

FITTING SIZE		37° JIC FITTINGS	FITTING SIZE		ORB FITTINGS
1/4	-4	9 to 10 ft.lb.	1/4	-4	14 to 16 ft.lb.
5/16	-5	15 to 16 ft.lb.	5/16	-5	18 to 20 ft.lb.
3/8	-6	20 to 22 ft. lb.	3/8	-6	24 to 26 ft.lb.
1/2	-8	30 to 33 ft.lb.	1/2	-8	50 to 60 ft.lb.
5/8	-10	40 to 44 ft. lb.	5/8	-10	72 to 80 ft. lb.
3/4	-12	70 to 77 ft.lb.	3/4	-12	125 to 135 ft. lb.
7/8	-14	82 to 90 ft. lb.	7/8	-14	160 to 180 ft.lb.
1	-16	94 to 104 ft.lb.	1	-16	200 to 220 ft. lb.
1 1/4	-20	120 to 132 ft.lb.	1 1/4	-20	210 to 280 ft. lb.
1 1/2	-24	131 to 144 ft.lb.	1 1/2	-24	270 to 360 ft.lb.
2	-32	300 to 330 ft.lb.			

The following torque specifications are for steel ORB fittings into aluminum.

FITTING SIZE		ORB FITTINGS	FITTING SIZE		ORB FITTINGS
1/4	-4	5 to 7 ft.lb.	3/4	-12	40 to 45 ft.lb.
5/16	-5	8 to 10 ft.lb.	7/8	-14	50 to 55 ft.lb.
3/8	-6	10 to 12 ft.lb.	1	-16	90 to 99 ft.lb.
1/2	-8	21 to 24 ft.lb.	1 1/4	-20	80to 90 ft.lb.
5/8	-10	27 to 30 ft.lb.			

Tandem Pump

Description	Qty.	Specification
Front Support	1	60 (+/- 2)
Rear Mounting	2	60 (+/- 2)
Trunion Seal Carrier	4	20 (+/- 2)
Trunion Seal Cover	4	20 (+/- 2)
Relief Valve	4	40 (+/- 10)
Charge Relief Cap	1	40 ~ 100
Tandem Section	4	40 (+/- 5)
Gear Pump	2	30 (+/- 2)

Torque Motor

Description	Qty.	Specification
Valve Housing	8	81 ft lbs
Bearing Housing	8	65 ft lbs
Bearing, Retaining Ring	8 bolts	7 ft lbs
Mounting	4	80ft lbs

SECTION 3 FINAL DRIVE

Specifications & Maintenance	3.1
Chart	pg. 3-2
Lubrication	3.2
Checking the Oil	pg. 3-3
Adding Oil	pg. 3-3
Changing the Oil	pg. 3-3
Drive Chain	3.3
Inspection	pg. 3-4
Removal	pg. 3-5
Installation	pg. 3-6
Drive Motor Sprocket	3.4
Replacement	pg. 3-7
Axle Assembly	3.5
Illustration	pg. 3-8
Removal	pg. 3-9
Inspection	pg. 3-10
Installation	pg. 3-11 ~ 3-13
Stud Replacement	pg. 3-14
Trouble Shooting	3.6
Chart	pg. 3-15



SPECIFICATIONS & MAINTENANCE 3.1

Specifications

Chain Size	ANSI 100
Approved Chain Manufacturer	Tsubaki
Lubricating Oil	10W30 API Classification SJ
Oil Capacity (each)	4.5 gal (17 Liters)
Torque Specifications:	
Motor Sprocket Bolt	40 ft lbs (54 Nm)
Wheel Nuts.....	100 - 110 ft lbs (135 - 149 Nm)
Tire Pressure	45 ~ 50 psi (310 ~ 345 kPa)

Maintenance Initial Check (hrs) Check Every (hrs)

Tire Pressure	8	8
Wheel Nut Torque.....	8	8
Lubrication Oil.....	50	150 (*)
Motor Mounting Nuts	50	150
Axle Bearing Pre-load	50	150

(*) Change every 1000 hours.

LUBRICATION 3.2

Checking The Oil Level

The loader has 2 independent final drive housings. When checking the oil level ensure the loader is on a level surface.

- 1 Remove the top (upper) check plug located between the 2 tires at the side of the loader. (Fig. 3.2A)
The oil level should be at the top of the check hole with a little to trickle out.



WARNING

Never work under a raised boom arm without the boom supports engaged and the engine shut off.

Adding Oil

Oil should be added with the loader on a level surface.

- 1 Remove any attachment, raise the boom arms and engage the boom support pins. Shut off the engine.
- 2 Remove the oil level check plug as outlined above. (Fig. 3.2A)
- 3 Remove the seat plate and front bulkhead assembly.
- 4 Remove the vented filler plug. (Fig. 3.2B)
- 5 Add 10W30 API classification SJ oil until it begins to flow out the upper check hole. Total final drive housing capacity per side is 4.5 gal (17 liters).
- 6 Replace all plugs.

IMPORTANT

Check the final drives closely for damaged seals or other leaks if the oil level is excessively low.

Changing The Oil

Ensure the loader is on a level surface before changing the oil.

- 1 Shut off the engine.
- 2 Slide a drain pan under one of the lower drain plugs located at the side of the loader, between the wheels. (Fig. 3.2A) Be prepared to contain 4.5 gal (17 liters) of oil.
- 3 Remove the drain plug. Allow the oil to drip completely out of the final drive housing. Replace the drain plug. Dispose of the waste oil in an environmentally friendly manner. If the oil is contaminated, remove the side inspection cover to flush the housing. (Fig. 3.2C)
- 4 Replenish the oil as outlined above in Adding Oil with 10W30 API classification SJ oil.

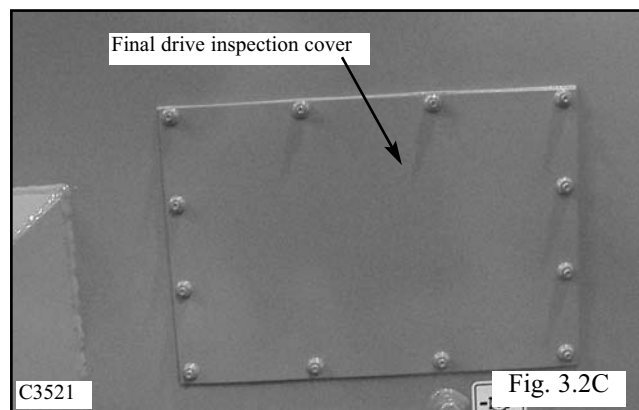
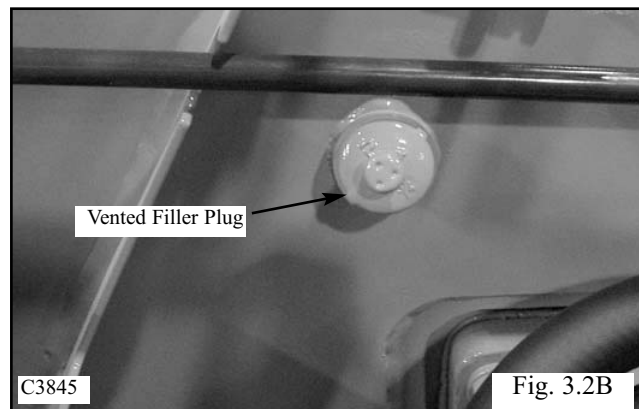
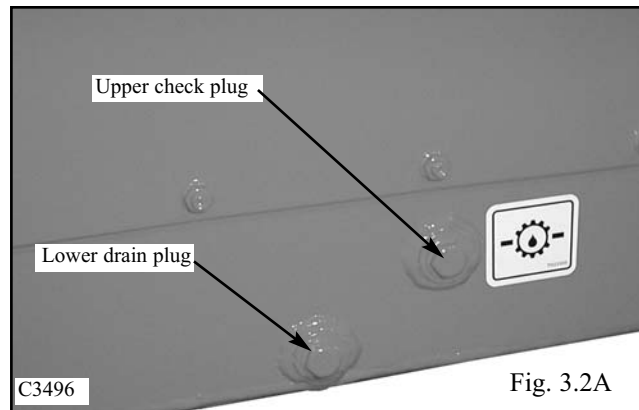

DRIVE CHAIN 3.3

Chain Inspection

The drive chains should be inspected for wear or damage after the first 50 hours of operation and every 150 hours thereafter, or at any time the final drive inspection cover is removed. If the chain shows any sign of wear or damage replace it. (Fig. 3.3A) Inspect as follows:

1. Inspect the chain for excessive roller wear
2. Inspect the chain for excessive wear on the link plates
3. Inspect the connection link cotter pins for wear or damage caused by interference.
4. Check the sprocket for excessive wear or damage such as broken teeth or sharp/rounded teeth.
5. If the chain is removed from the loader, check for stiffness caused by wear between the pins and bushings.
6. If the chain is removed from the loader, check that when laid out it runs straight and not to one side, indicating misalignment.

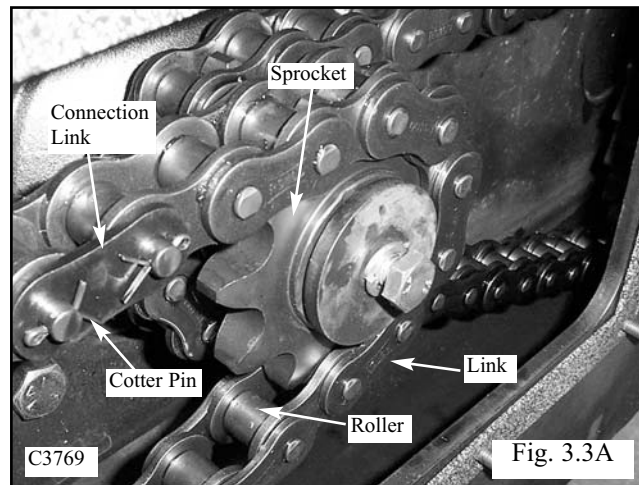

3

DRIVE CHAIN 3.3

Chain Removal

- 1 Remove any attachment, raise the boom arms and engage the boom support pins. Shut off the engine.
- 2 Block the loader securely with all 4 wheels clear of the ground.
- 3 Remove the wheels from the side of the loader the chain is to be removed.
- 4 Clean the excess dirt from the final drive housing. Drain the plug area and the inspection cover area located between the 2 axle towers. (Fig. 3.3B)
- 5 Remove the lower drain plug and drain the oil. Refer to Section 3.2 page 3-3.
- 6 Remove the final drive inspection cover. (Fig. 3.3B)
- 7 Rotate the chains, if necessary, to locate the master connecting link by starting the engine and engaging the steering control. Be sure the loader is securely raised clear of the ground. Shut off the engine.

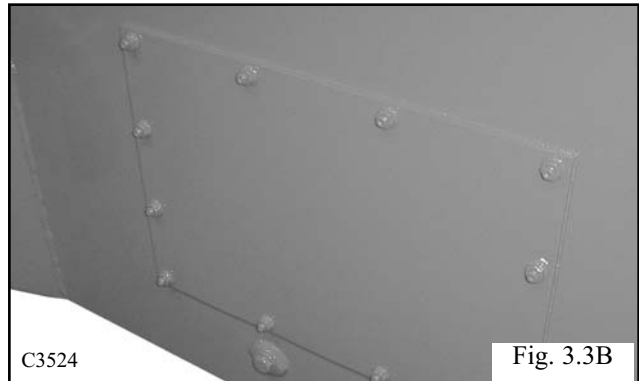

- 8 Remove the cotter pins from the master connecting link and remove the connecting link. (Fig. 3.3C) The connecting link is a press fit type and will need to be supported as you drive the link pins through the link plate.

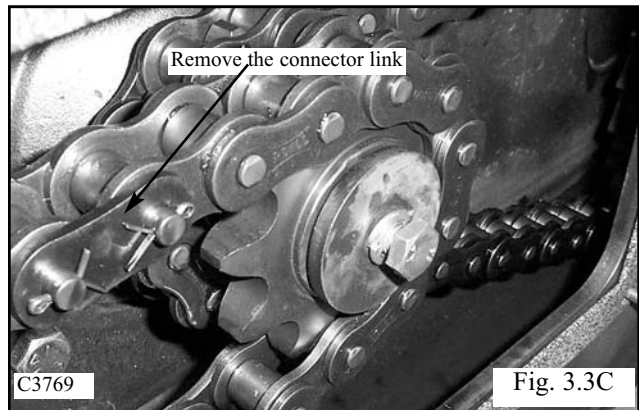

- 9 Remove the front or rear chain from the housing by turning the axles by hand and pulling the slack chain out the inspection cover area. (Fig. 3.3D)

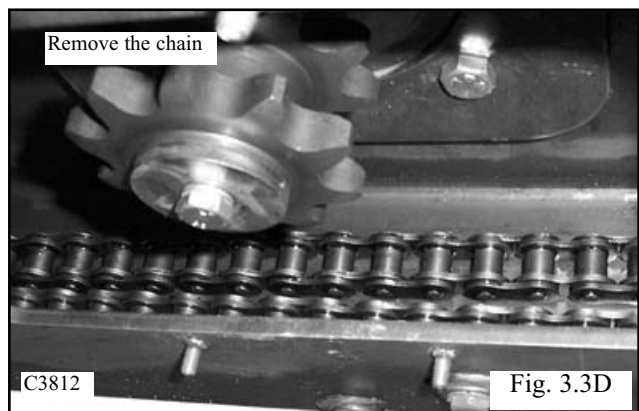

DRIVE CHAIN 3.3

Chain Installation

1 Install the wrapped chain into the final drive housing. (Fig. 3.3E)

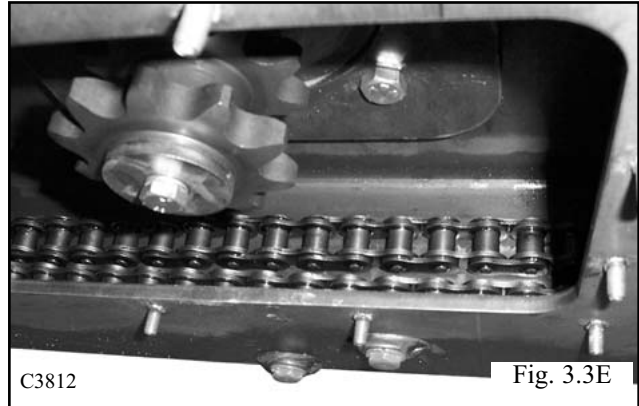

2 Place one end of the front chain over the top of the front axle sprocket. Rotate the axle and bring the chain along the bottom of the final drive housing to approximately the center. (Fig. 3.3F) Wrap the other end of the chain around the motor sprocket teeth closest to the motor.



3 Place the ends together and install the new connecting link so that the cotter pins face away from the inspection cover. (Fig. 3.3H). Bend the ends of the cotter pins at least 90 degrees.

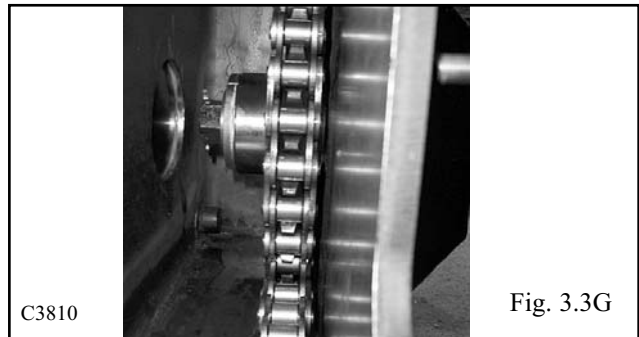

4 Wrap the rear chain over the rear axle sprocket. Rotate the axle and chain around the bottom of the final drive housing and around the bottom of the motor sprocket closest to the inspection cover opening until the ends of the chain meet together.

5 Install a new connecting link. (Fig. 3.3H) Place the connecting link into the chain so the cotter pins face the inspection cover hole. Bend the ends of the cotter pins at least 90 ° apart.

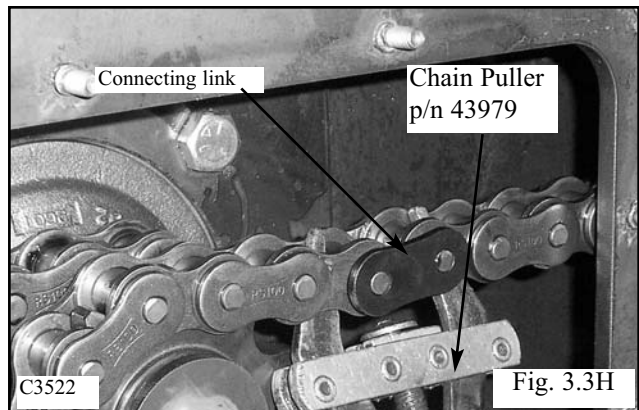

6 Replace the inspection cover using the gasket. Do not over tighten the inspection cover nuts 15 ft lbs maximum. (20 Nm)

7 Replace the wheels and torque the wheel nuts to 100 to 110 ft lbs. (136 to 149 Nm).

3

DRIVE MOTOR SPROCKET 3.4

Replacement

The torque motor drive sprocket can be removed from the loader without removing the drive motor from the final drive housing.

- 1 Place the loader on a level surface, engage the parking brake and shut off the engine.
- 2 Raise the loader securely from the ground and remove the wheels on the side to be worked on.
- 3 Remove the inspection cover located between the axle assemblies. (Fig. 3.4A)

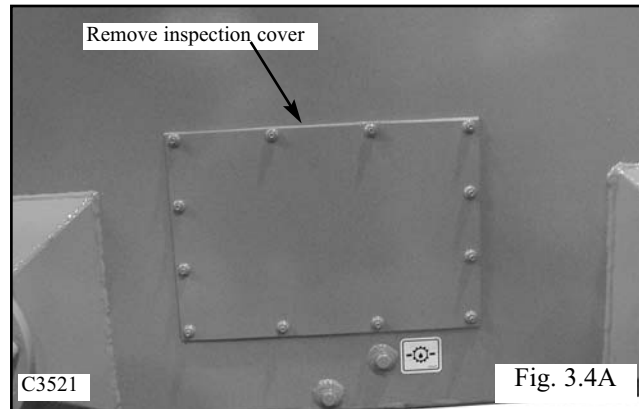

- 4 Remove the connector link from the front and rear chains. (Fig. 3.4B)

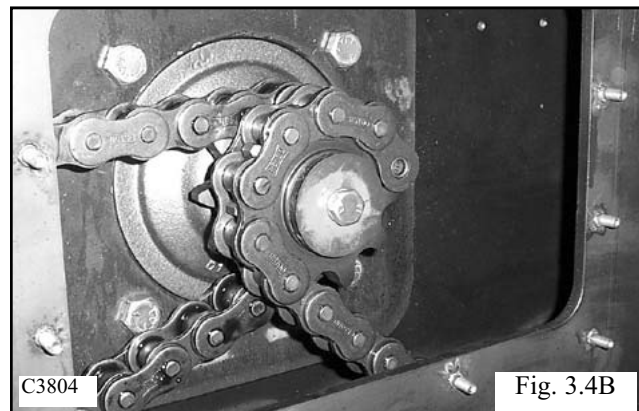

- 5 Remove the bolt retaining the drive sprocket to the drive motor. (Fig. 3.4C)

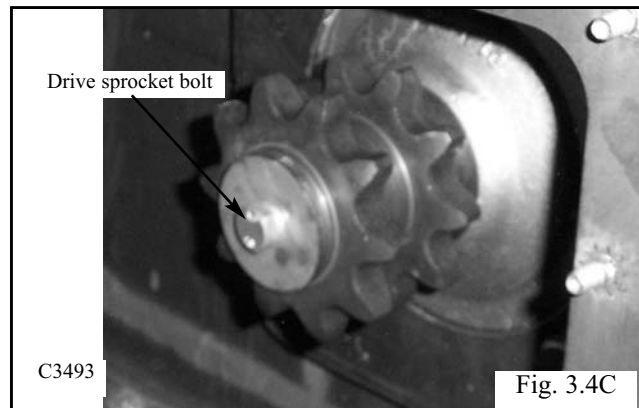

- 7 Replace the drive sprocket in the reverse order above. Apply Loctite 242 (blue) to the drive sprocket bolt and torque the bolt to 40 ft lbs (54 Nm).

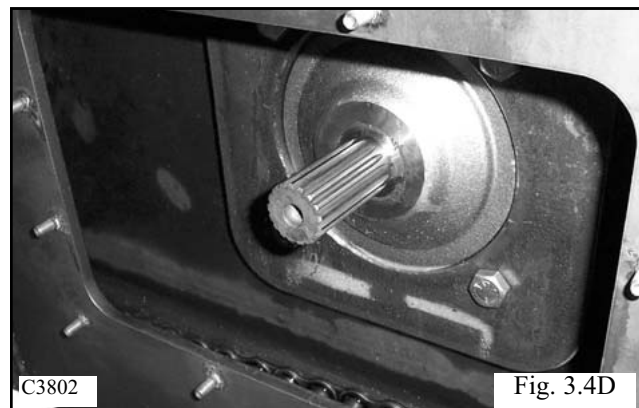

AXLE ASSEMBLY 3.5

Axle Assembly (Front Assy. Shown)

C5428

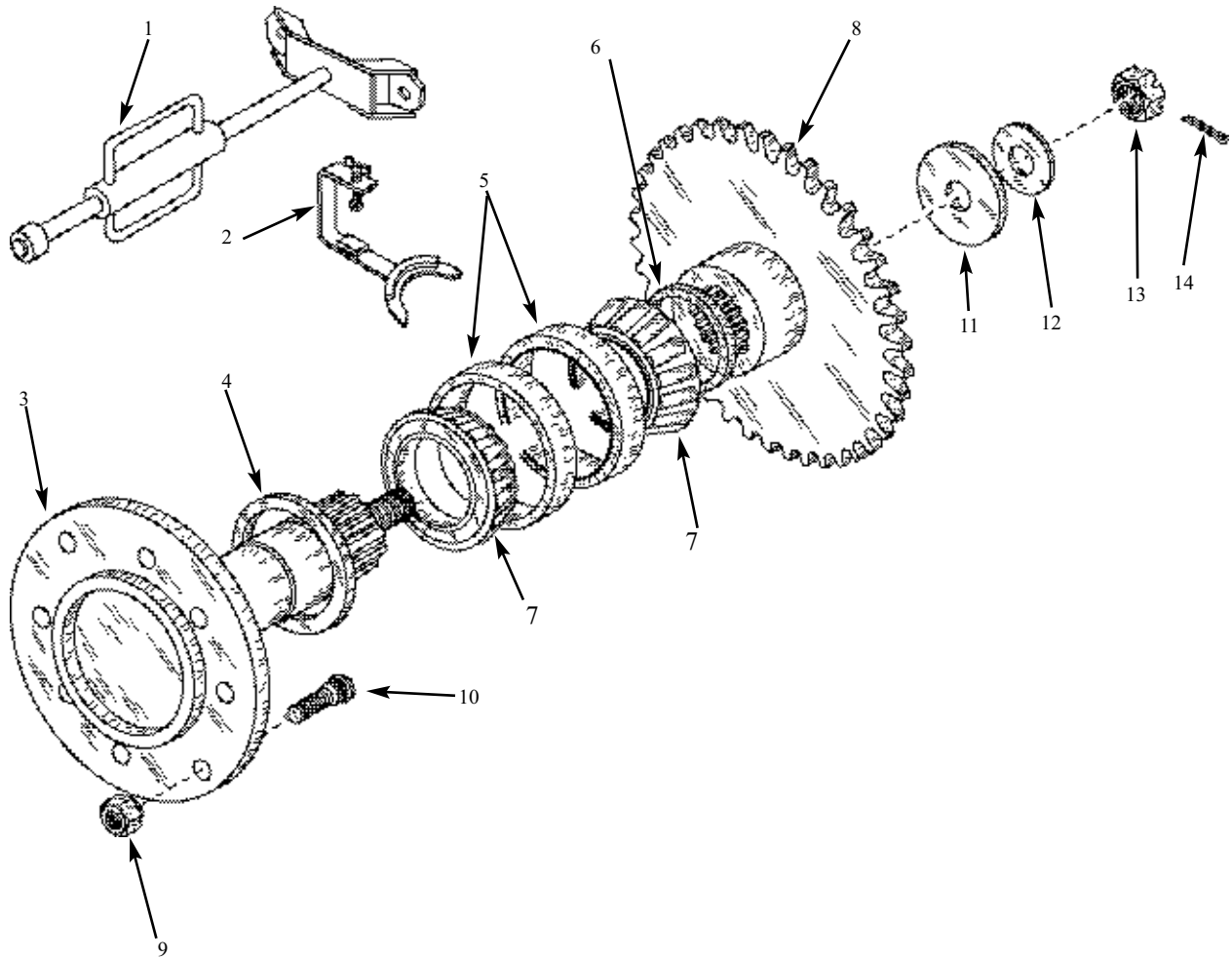

- | | |
|-------------------------------|------------------------|
| 1. Axle Puller | 10. Wheel Stud |
| 2. Seal Installation Tool (2) | 11. Plate, Axle Washer |
| 3. Axle Assy | 12. Washer, Axle |
| 4. Seal | 13. Castle Nut |
| 5. Bearing, Cup | 14. Cotter Pin |
| 6. Plate, Axle Spacer | |
| 7. Bearing, Cone | |
| 8. Sprocket | |
| 9. Wheel Nut | |

3

AXLE ASSEMBLY 3.5

Axle Removal

- 1 Remove any attachment, raise the boom arms and engage the boom support pins. Shut off the engine.
- 2 Block the loader securely with all 4 wheels clear of the ground.
- 3 Remove the wheels from the side of the loader the chain is to be removed.
- 4 Clean the excess dirt from the final drive housing drain plug area and the inspection cover area located between the 2 axle towers.
- 5 Drain the lubricating oil from the final drive housing. Refer to Section 3.2 page 3-3.
- 6 Remove the final drive inspection cover located between the 2 axles.
- 7 Remove the drive chain from the sprocket of the axle being replaced. Refer to Section 3.3 page 3-5.
- 8 **FRONT AXLE:** Remove the foot pedal assembly if so equipped. Refer to Section 4.
- 9 Remove the inner axle cover plate from the final drive housing. (Fig. 3.5A)
- 10 **REAR AXLE:** Remove the inner axle cover plate from the final drive housing.
- 11 Remove the split pin from the castle nut on the end of the axle. (Fig. 3.5B)

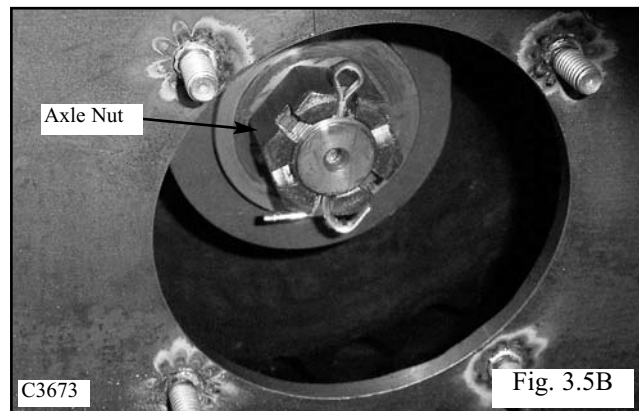
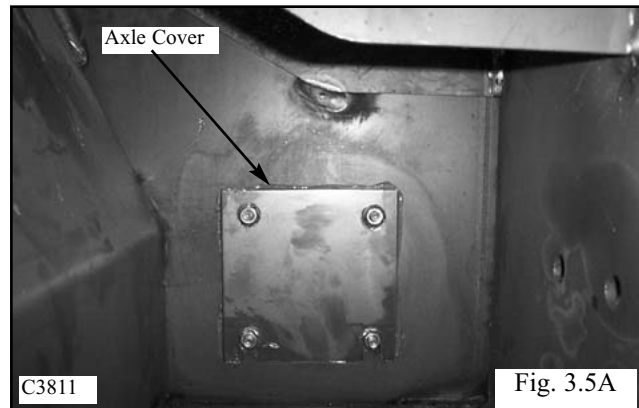

- 12 The axle may be held stationary by inserting a bar between the wheel studs.

- 13 Remove the castle nut and axle washer. (Fig. 3.5C)

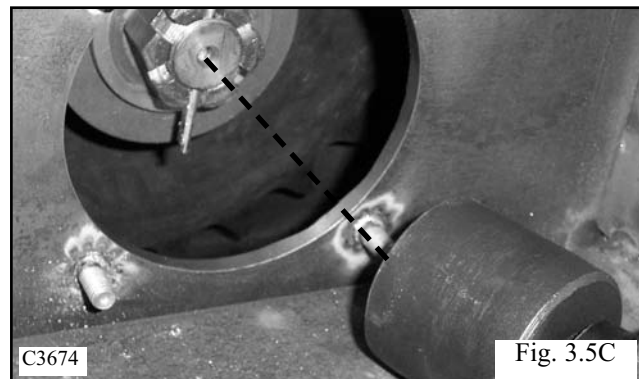

3

AXLE ASSEMBLY 3.5

14 Attach a special axle puller tool, Thomas P/N 960475, to the axle flange wheel studs using the wheel nuts that are on the loader. (Fig. 3.5D)

15 Using the slide hammer action of the special puller, remove the axle (Fig. 3.5E). The rear bearing, axle spacer and axle sprocket will remain in the final drive housing.

16 Remove the axle sprocket, axle spacer and bearing from the final drive housing through the inspection cover area.

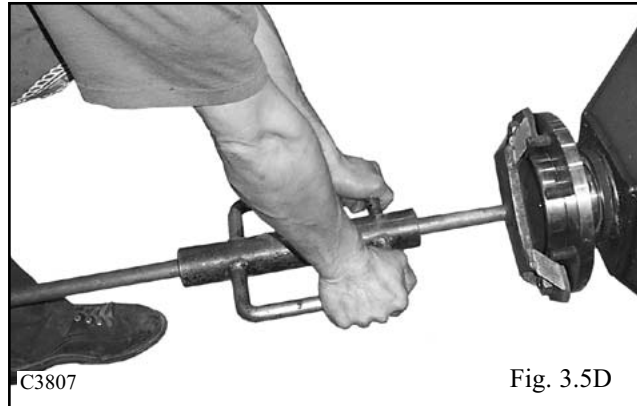

17 Using a bearing puller, remove the bearing still pressed in place on the axle. (Fig. 3.5F)

18 Remove and discard the axle oil seal.

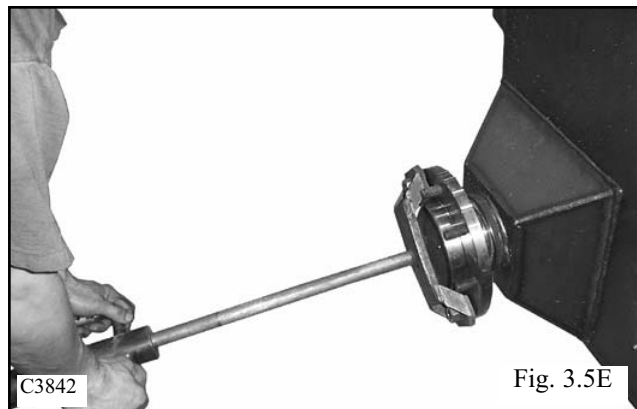

Inspection

1 Inspect the seal surface area for scaring, pitting or nicks (Fig. 3.5G). Minor scratches may be removed using fine emery cloth. Replace the axle if worn excessively.

2 Inspect the axle threads for damage (Fig. 3.5G). Replace axle if the threads are non serviceable.

3 Inspect axle spline (jFig. 3.5G) for wear and replace if necessary.

4 Replace any axle studs as required (page 3-14)

5 Inspect the axle sprocket for abnormal tooth wear and inspect sprocket spline for wear. Replace the sprocket if necessary.

6 Inspect the bearing races in the final drive housing. Replace them if necessary using a brass drift punch and hammer. Cooling the replacement races in a freezer will aid in using this procedure.

7 Replace the bearings if new races are installed or if they are pitted or damaged.

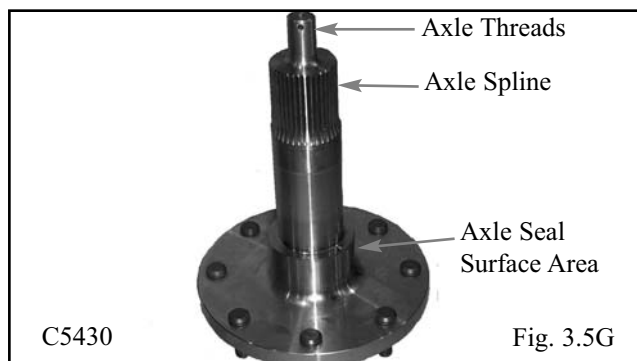
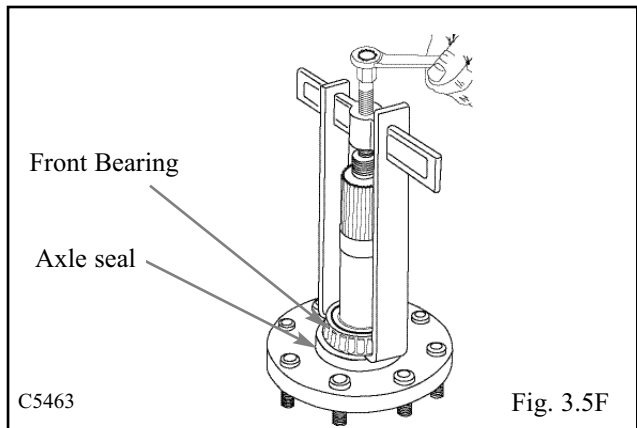

3

AXLE ASSEMBLY 3.5

Axle Installation

- 1 Check the axle seal surface area for damage. Minor scratches may be repaired using fine emery cloth.
- 2 Inspect the axle threads for damage. Replace axle if the threads are non serviceable.
- 3 Inspect the splined teeth for wear. Replace the axle if the splined teeth do not fit tightly into the sprocket spline.
- 4 Replace any axle studs as required.
- 5 Lubricate the axle oil seal with light grease.
- 6 Install the seal onto the axle. The seal part number stamping must face the flange side of the axle.
- 7 Using a press, install the front, or outer, bearing onto the axle. Be sure to support the axle up off the wheel studs to prevent damaging the wheel studs. (Fig. 3.5H)

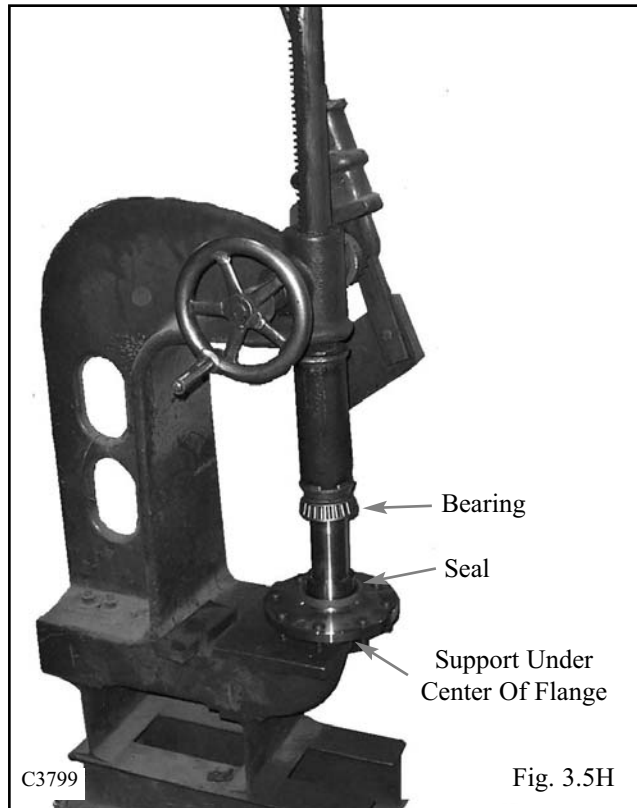

- 8 Place the front axle sprocket into the final drive housing with the hub facing toward the bearing race area. (outside) Note: The rear axle sprocket hub faces inside.

- 9 Apply gasket sealant to the outer edge of the final assy oil seal surface. (Fig. 3.5I) Take care, make sure none gets on the bearing surface.

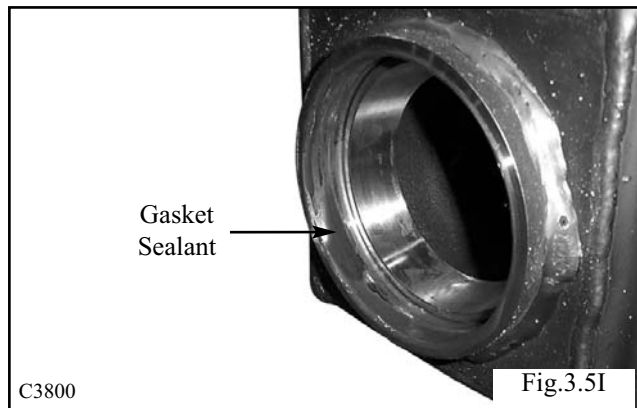

- 10 Guide the axle into the final drive housing. (Fig. 3.5J)

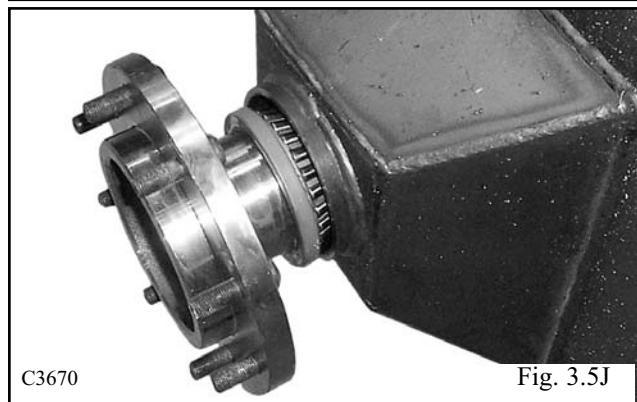

3

AXLE ASSEMBLY 3.5

11 Place 2 seal installation tools, Thomas P/N 958674, equally spaced around the axle flange, behind the seal. (Fig. 3.5L). This special tool must be used to properly locate the seal into the final drive housing.

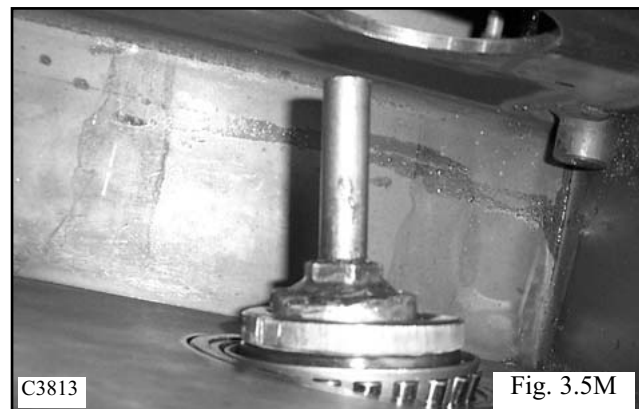
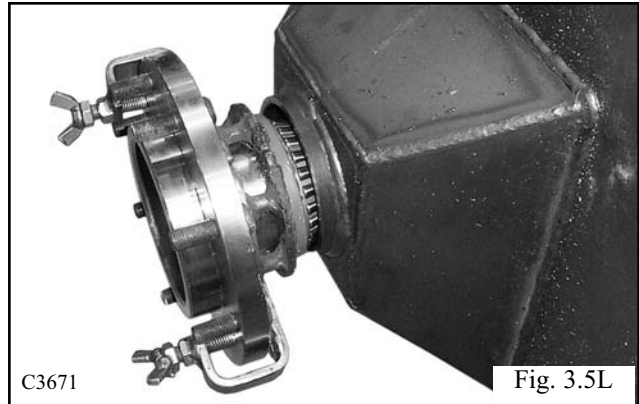

12 Place the rear (inside) axle bearing onto the axle. (Fig. 3.5M, 3.5N) Front axle assembly is shown. Sprocket is reversed for rear axle assembly.

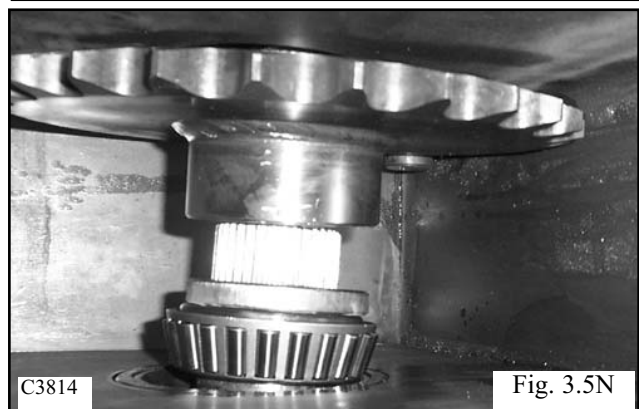

13 Start the axle into the drive sprocket. Place the small axle washer and castle nut onto the threaded end of the axle. (Fig. 3.5O)

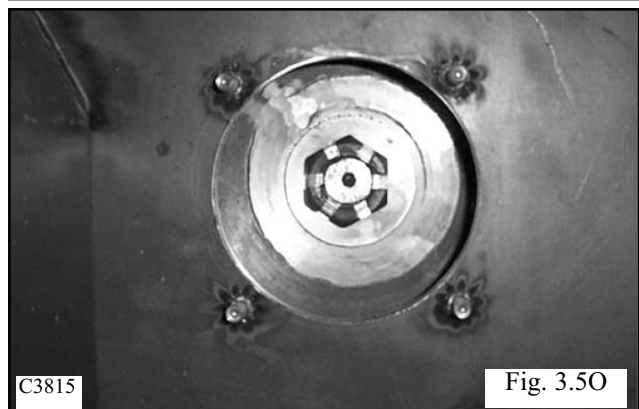

3

AXLE ASSEMBLY 3.5

14 Tighten the castle nut and guide the axle into the final drive housing as straight as possible to prevent damaging the seal. Tap the axle flange with a hammer if necessary to assist the installation.

As the castle nut is being tightened the rear (inside) bearing is being pressed into place and the axle oil seal is simultaneously pulled into the proper location into the final drive housing. (Fig. 3.5P)

15 When the castle nut will not turn on any further tap the face of the flange with a hammer to ensure the seal and bearing has seated into place.

16 Remove the castle nut (Fig. 3.5Q), remove the small washer and add the large axle washer (Fig. 3.5R).

17 Install the axle washer and castle nut. Tighten the castle nut to remove all axle bearing end play. (Zero pre-load) Continue tightening until the split pin hole in the axle will align with the castle nut (Fig. 3.5S).

18 Install the split pin. Bend the end of the split pin straight back against the axle washer.

19 Install the axle cover gasket and axle cover . Do not over tighten the retaining nuts. 15 ft lbs maximum. (20 Nm)

20 Install the drive chain. Refer to Section 3.3 page 3-6.

21 Install the inspection cover gasket and inspection cover. Do not over tighten the retaining nuts. 15ft lbs maximum. (20 Nm)

22 Fill the final drive housing to the correct level using 10W30 API classification SJ oil. Refer to Section 3.2 page 3-3 for procedure.

23 Install the wheels. Torque the wheel nuts to 100 to 110 ft lbs (135 to 149 Nm).

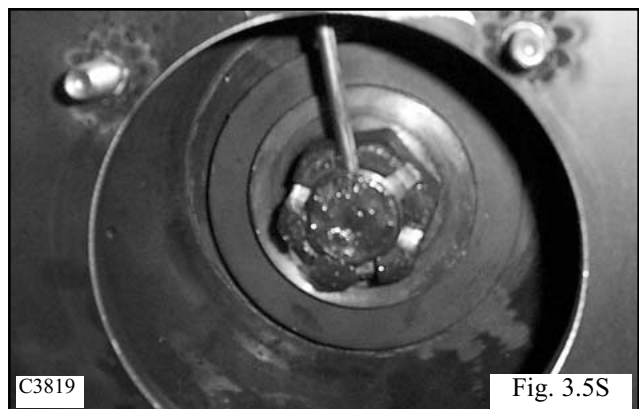
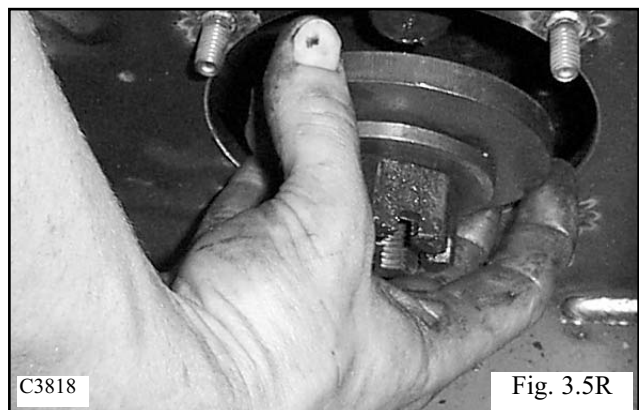
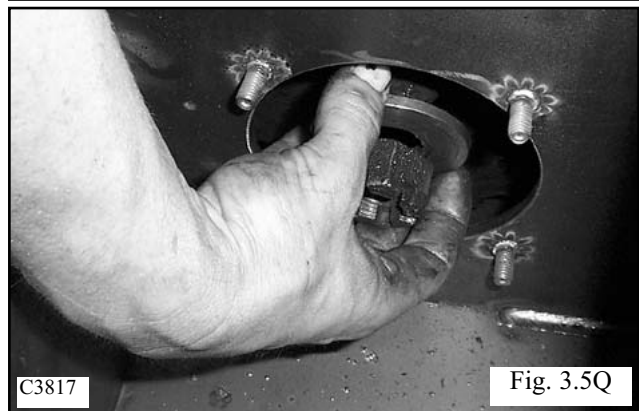
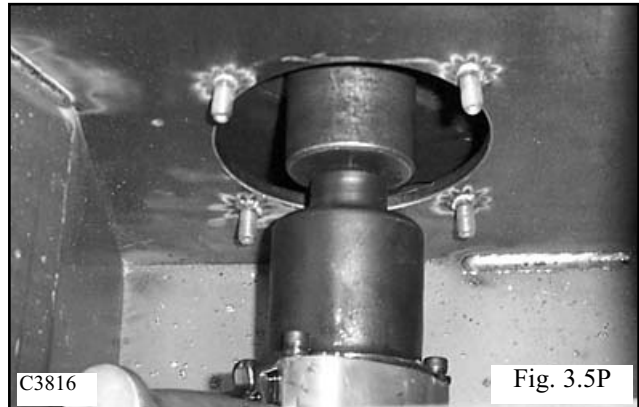

AXLE ASSEMBLY 3.5

Axle Stud Replacement

- 1 Remove any attachment, raise the boom arms and engage the boom locks. Shut off engine
- 2 Block the loader securely with all 4 wheels clear of the ground.
- 3 Remove the wheel from the axle the stud is to be replaced.
- 4 Strike the stud with a hammer to remove from the axle flange. (Fig. 3.5T)
- 5 Place a new stud in position behind the axle flange. Line up the splines on the stud with the splines cut into the axle flange. (Fig. 3.5U)
- 6 Put a few drops of light oil on the stud spline. (Fig. 3.5V)
- 7 Place a wheel nut inverted on the stud. Tap the end of the stud with a hammer as you tighten the wheel nut. This will draw the stud into place in the axle flange. (Fig. 3.5W & 3.5X)
- 8 Remove the wheel nut and discard. Replace with new wheel nut.
- 9 Replace the wheel and torque the wheel nuts to 100 to 110 ft lbs. (135 to 149 Nm). (Fig. 3.5Y)

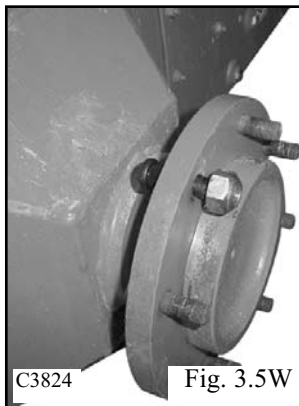
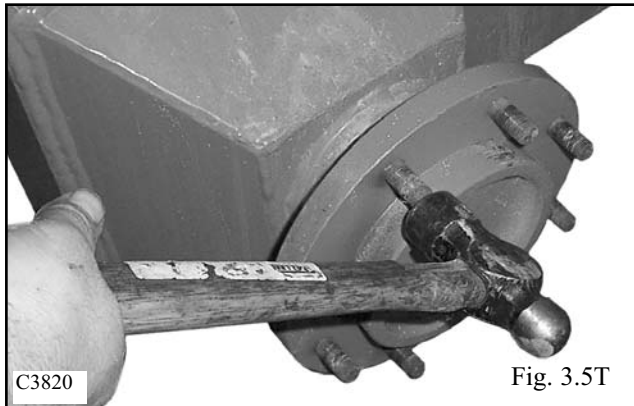

IMPORTANT

Torque the wheel nuts daily to prevent stud and/ or wheel damage.

TROUBLE SHOOTING 3.6

3

Problem	Cause	Corrective Action	Section
Final drive noisy.	No lubricating oil.	Check oil level. Add 10W30 API SL oil to correct level.	3.2
	Axle has too much end play. (Bearing pre-load)	Check and adjust the bearing pre-load on the axle bearings	3.6
No drive on one side.	Drive chain failure.	Inspect the drive chain and connecting link. Replace damaged parts.	3.3
	Drive motor sprocket failure	Inspect the drive sprocket and splines. Replace parts as required.	3.5 2
	Drive motor or hydrostatic system failure	Refer to the hydrostatic drive section. Diagnose and make repairs as required.	2
Lubrication oil leaking through the filler / breather cap.	Lubricating oil level too high.	Check the oil level.	3.2
	Drive motor shaft seal leakage.	Inspect and repair damaged parts.	2
Wheel studs shearing off.	Wheel nuts loose.	Replace the wheel studs. Check wheel nut torque daily. Torque wheel nuts at 100 to 110 ft lbs. (135 to 149 Nm)	3.6
Wheel stud threads stripped.	Wheel nuts over tightened.	Replace the wheel studs. Check wheel nut torque daily. Torque wheel nuts at 100 to 110 ft lbs. (135 to 149 Nm)	3.6